

Panasonic



Digital HD Video Cassette Recorder



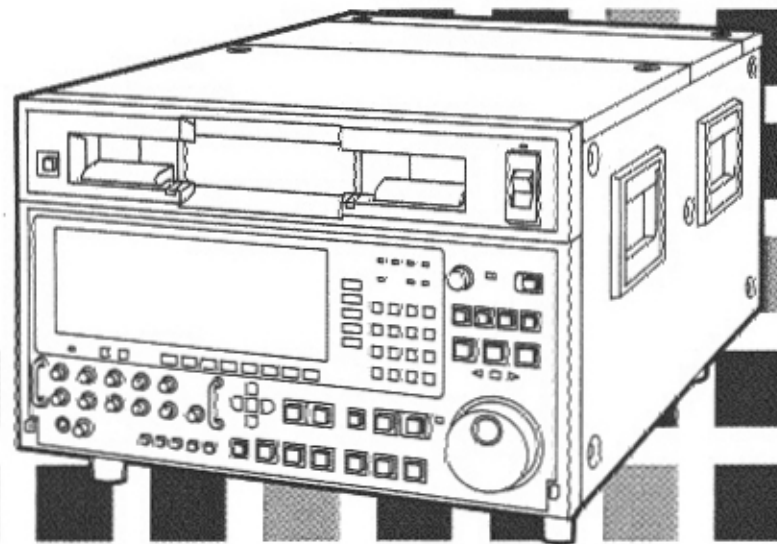

AJ- **HD2700** P

Operating Instructions



Precautions for Use

Since this VTR is designed for metal tapes only, make sure that only the designated tapes are used. An ordinary VHS tape cannot be used. Removal of the covers on electrical appliances for maintenance purposes may lead to electric shocks. Personnel should therefore adhere strictly to the normal safety precautions. Some customer-preference switches are located on printed circuit boards within the unit. Be sure to turn off the power prior to opening the unit, before changing the position of any switch, and especially before removing or reinserting any circuit board.

| | |
|---|---|
|    CAUTION: TO REDUCE THE RISK OF ELECTRIC SHOCK, DO NOT REMOVE COVER (OR BACK). NO USER-SERVICEABLE PARTS INSIDE. REFER SERVICING TO QUALIFIED SERVICE PERSONNEL. | FCC NOTE: This device complies with Part 15 of the FCC Rules. To assure continued compliance follow the attached installation instructions and do not make any unauthorized modifications. |
|  <p>The lightning flash with arrowhead symbol, within an equilateral triangle, is intended to alert the user to the presence of uninsulated "dangerous voltage" within the product's enclosure that may be of sufficient magnitude to constitute a risk of electric shock to persons.</p> | This equipment has been tested and found to comply with the limits for a Class A digital device, pursuant to Part 15 of the FCC Rules. These limits are designed to provide reasonable protection against harmful interference when the equipment is operated in a commercial environment. This equipment generates, uses, and can radiate radio frequency energy and, if not installed and used in accordance with the instruction manual, may cause harmful interference to radio communications. Operation of this equipment in a residential area is likely to cause harmful interference in which case the user will be required to correct the interference at his own expense. |
|  <p>The exclamation point within an equilateral triangle is intended to alert the user to the presence of important operating and maintenance (servicing) instructions in the literature accompanying the appliance.</p> | |
| CAUTION: TO REDUCE THE RISK OF FIRE OR SHOCK HAZARD AND ANNOYING INTERFERENCE, USE THE RECOMMENDED ACCESSORIES ONLY. | |
| WARNING: TO REDUCE THE RISK OF FIRE OR SHOCK HAZARD, DO NOT EXPOSE THIS EQUIPMENT TO RAIN OR MOISTURE. | |

 is the safety information.

Table of Contents

General

| | |
|-----------------------------|----|
| Operating precautions | 8 |
| Features | 9 |
| Specifications | 11 |

Controls and their functions

| | |
|-------------------------|----|
| Front panel | 15 |
| Connector section | 23 |

Connections

| | |
|--|----|
| Connections for single unit | 28 |
| Connections for two units | 29 |
| Connection with editing controller | 30 |

Video tapes

| | |
|---|----|
| Tapes | 31 |
| • Prohibiting recording on a tape | 31 |

Operations

| | |
|--|----|
| Recording | 32 |
| • Simultaneous playback monitoring | 34 |
| • Checking the input signals | 34 |
| Recording digital signals | 35 |
| Playback | 37 |
| Basic operations | 38 |
| • Stop/FF/REW/READY | 38 |
| • JOG/Shuttle | 39 |
| • Variable (VAR) | 40 |
| • Tape speed override (TSO)/CUE | 41 |
| Manual editing | 43 |
| Manual audio cross editing | 44 |
| Automatic insert/assemble editing | 45 |
| Spot erase editing | 47 |
| Audio split editing | 48 |
| • Edit OUT point preview | 49 |

Table of Contents (Continued)

Menus

| | |
|------------------------------|----|
| Switching on the power | 50 |
|------------------------------|----|

HOME

| | |
|--|----|
| HOME menu displays | 51 |
| HOME menu | 56 |
| HOME SET UP menu | 58 |
| •Reference | 60 |
| •CF DET (color frame detection) mode | 61 |
| •Programmed play function | 61 |

VIDEO

| | |
|---|----|
| VIDEO IN menu | 62 |
| VIDEO OUT menu | 64 |
| •Video output signal adjustment | 66 |
| AUDIO OUT SET UP/VIDEO OUT STATE menu | 67 |
| •Selecting the TAPE/EE output signal | 68 |
| VIDEO OUT/DOWN CONV SET UP menu | 69 |

AUDIO

| | |
|---|----|
| AUDIO IN menu | 71 |
| AUDIO IN SET UP menu | 73 |
| •Mixing recording | 75 |
| AUDIO OUT menu | 77 |
| AUDIO OUT SET UP menu | 79 |
| •Audio to video output adjustment | 81 |
| •Fade function | 81 |

TIME CODE

| | |
|--|----|
| TC/CHR menu | 82 |
| •Changing the superimposing position | 85 |
| TABLE OF USER BIT SETTINGS | 87 |

CUE

| | |
|----------------------------------|----|
| MULTI CUE (USER) menu | 88 |
| •Entering cue points | 91 |
| •Changing cue points | 92 |
| •Clearing cue data | 92 |
| •Clearing all the cue data | 92 |
| •Cue search and preroll | 92 |

| | |
|---|-----|
| MULTI CUE (EXTEND) menu | 93 |
| •Selecting a page | 95 |
| •Page protection | 95 |
| •Entering, changing and clearing the cues | 95 |
| •Clearing all the cues | 95 |
| MULTI CUE (EXTEND) SET UP menu | 96 |
| | |
| MANUAL EDIT | |
| INSERT/ASSEMBLE MANUAL EDIT menu | 98 |
| INSERT/ASSEMBLE MANUAL EDIT SET UP menu | 100 |
| •EDIT REC INHIBIT mode display | 102 |
| •Sequence of priority for inhibit modes | 102 |
| •Selecting the SOFTWARE inhibit channel | 103 |
| •REC ENV display | 103 |
| •Tracking | 104 |
| •Selecting the audio fade time | 106 |
| | |
| AUTO EDIT | |
| INSERT/ASSEMBLE AUTO EDIT menu | 107 |
| •Selecting the editing channel | 109 |
| •Tape position indicator | 109 |
| •Duration | 109 |
| •Edit data input section | 110 |
| •Variable memory function | 113 |
| •Variable memory editing | 114 |
| INSERT/ASSEMBLE AUTO SET UP menu | 115 |
| •Selecting the preroll time | 118 |
| •Setting DLY STRT | 118 |
| •Setting EDIT REC INHIBIT | 118 |
| | |
| SET UP | |
| SET UP menu | 119 |
| INTERFACE SET UP menu | 121 |
| •Mode and connector correspondance table | 123 |
| •Setting the RS-232C parameters | 124 |
| •Setting the V/A control parameter | 124 |
| •Setting the CH ASSIGN audio channel | 125 |
| PANEL SET UP menu | 126 |

Table of Contents (Continued)

SET UP

| | |
|---|-----|
| PANEL SET UP (REMOTE OP MAP) menu | 128 |
| •F5 (MAP MODE)/F6 (FUNCTION) key combined settings | 130 |
| •OP MAP setting method | 130 |
| PANEL SET UP (LOCAL OP MAP) menu | 131 |
| •OP MAP setting method | 132 |
| USER SET UP menu | 133 |
| •Saving user files | 135 |
| •Locking user files | 136 |
| •Updating user files | 136 |
| •Deleting user files | 137 |
| •Loading user files | 137 |
| •Automatically loading a file when the power is turned on | 137 |
| •Copying filenames | 138 |
| SET UP SYSTEM menu | 139 |

TEST

| | |
|---|-----|
| TEST menu | 141 |
| •OPERATION TIME display | 142 |
| •SOFTWARE VERSION | 142 |
| •SERIAL No. display | 142 |
| VIDEO TEST menu | 143 |
| •Circuit test | 145 |
| •Video input signal selection | 146 |
| RF TEST menu | 147 |
| •Error rate display | 149 |
| •Recording current optimization | 149 |
| •Auto equalizing function | 149 |
| RF ADJUSTMENT VALUE DISPLAY (RF menu) | 150 |
| AUDIO TEST menu | 151 |
| MECHA TEST menu | 152 |
| SYSTEM TEST menu | 154 |
| SERVO TEST menu | 155 |
| •Error rate display | 157 |
| •Tracking adjustment | 157 |
| TEST FRONT menu | 158 |
| TEST FRONT KEY CHECK menu | 159 |
| TEST FRONT PANEL menu | 160 |
| •Dial/control, LEDs, Keys | 161 |

IC/CARD

| | |
|--------------------|-----|
| IC/CARD menu | 162 |
|--------------------|-----|

ERROR

| | |
|---------------------------------|-----|
| ERROR MESSAGES | 170 |
| •DIAG menu error messages | 171 |
| Active screen | 172 |
| Masked screen | 173 |
| Last screen | 174 |
| Error messages | 175 |
| •AUTO OFF error messages | 180 |
| •SYSTEM error messages | 183 |
| •OPERATION error messages | 186 |

Others

| | |
|--|-----|
| INTERNAL SWITCHES | 188 |
| CIRCUIT BOARDS | 189 |
| USING THE OPTIONAL BOARD AJ-MK30 | 190 |
| USING THE OPTIONAL DOWN-CONVERTER BOARD AJ-DFC2000 | 191 |
| REMOTE CONTROL | 191 |
| SCREEN LIFE-SAVING FUNCTION | 193 |
| VIDEO HEAD CLEANING | 194 |
| CONNECTOR SIGNALS | 195 |
| INSTALLATION | 201 |
| RACK-MOUNTING | 202 |
| TROUBLESHOOTING | 203 |
| TALBE OF MENU SCREEN TRANSITIONS | 204 |
| MENU LIST | 205 |
| INDEX | 213 |

Operating precautions

Power supply

Use an AC 120 V (U.S.A. and Canada) power supply.

- Be sure to take hold of the power plug when connecting and disconnecting the power cable.
- Do not run the power cable near a heating appliance.
- Do not place heavy objects on top of the power cable.
- Do not tamper with the power cable in any way.

No insertion of foreign matter

Do not insert or drop metal or any other foreign objects into the unit's openings (such as the cassette insertion slot).

If foreign objects have found their way inside the unit, contact the dealer from whom you purchased the unit.

Operation in this state can cause a fire or electric shocks.

No disassembly

A high voltage is supplied to some of the parts inside the unit, and touching these parts is therefore not only dangerous but may cause malfunctioning as well.

Leave all internal inspections and adjustments to the dealer from whom you purchased the unit.

DANGER: No operation if unit is malfunctioning

If smoke comes out or strange sounds or smells are detected from the unit, ask the dealer from whom you purchased the unit to conduct repairs.

When transporting the unit

The circuit boards of this unit are provided with clamping devices inside the front panel to prevent them from popping out.

Be sure to screw both sides of these clamps when transporting the unit.

Features

This HD VTR is a hi-vision digital VTR for recording and playing back the video and audio signals complying with BTAS-001A (1125/60 high-definition TV system studio standard) and SMPTE 274M standard.

By image-compressing the hi-vision signals and digitally recording them, this unit delivers up to 120 minutes of recording and playback using a 1/2" cassette.

While remaining compatible with HD systems which combine Panasonic's HD processor (AJ-HDP500) and D5 VTR, this integrated HD VTR is compact and lightweight and it consumes minimal power.

By switching the SYSTEM menu item, this HD VTR will also operate as a VTR which will record and play back 720/60 progressive scanning TV system (SMPTE 296M) signals.

Picture/sound quality with a reasonable price tag

•High picture quality digital recording of signals complying with the studio standard

The hi-vision studio standard signals, which have been 10-bit quantized using sampling frequencies of 74.25 MHz for the Y signals and 37.125 MHz for the PB and PR signals, are image-compressed and digitally recorded to meet the full range of specifications under the Hi-vision studio standard.

This enables the unit to record and play back signals with a wide range (Y: 30 MHz; PB, PR: 15 MHz) and signal-to-noise ratio of 60 dB which were difficult for conventional analog VTRs using a 1/2" tape to achieve, and it ensures that a high level of picture quality is maintained for every process from recording to editing.

•Compact size, light weight and low power consumption

This integrated HD VTR is 30% less bulky than an HD system which combined the company's HD processor (AJ-HDP500) and D5 VTR. More specifically, it is compact (height equivalent to 6U) and lightweight (110 lb), it keeps power consumption to the minimum (550 W): these are specifications which make it easy to use indeed.

•High cost performance

Using a newly developed image compression system and the D-5 format high-density recording technology, hi-vision digital recording can now be offered using 1/2" cassettes which makes for outstanding cost performance.

•4-channel digital audio with high sound quality

A high sound quality with a dynamic range of 100 dB is delivered by 20-bit 48 kHz sampling. Not only can recording, playback and editing be conducted separately for each of the 4 channels but channel mixing is also possible. Moreover, one channel is provided for the analog (cue) track.

•Compact 1/2" tape cassette

Two sizes of cassette, L (120 minutes) and M (60 minutes) can be used with this unit: this enables the size best suited to the intended application to be selected. The compact 1/2" cassette takes up minimal storage space and offer excellent handling ease.

I/O specifications and interfaces

•Serial digital I/O facilities

The unit is equipped with hi-vision serial digital interfaces which meet the BTAS-004A, S-005A and S-006A, SMPTE 292M standards and which enable both video and audio signals to be transferred using the same coaxial cable.

•Built-in down-converter function

A down-converter (AJ-DFC2000) can be installed in the unit as an option. This facilitates conversion into the 525-line standard TV system, and it makes the integrated production of Hi-Vision and standard TV broadcast much simpler.

In addition to the NTSC analog signals, a serial digital interface (SDI) signal which can switch the multiplex transfer of audio signals ON or OFF is included in the 525-line output signals. This SDI signal enables digital connection with a D3, D5 VTR or DVCPRO.

Features (Continued)

•AES audio input/output facilities

Separate digital audio inputs and outputs are provided for each of the 4 channels, and standard interfacing with a variety of digital audio units is possible. Twice as many output connectors as usual are available to enable a wide range of applications: for instance, one set can be used for the main connections while the other set is used for monitoring.

•Remote control

In addition to the standard 9-pin serial (RS-422A) connector, 50P parallel and RS-232C connectors are provided for remote control. An AV control connector is also featured.

Slow motion, search and editing functions

•Slow motion/jog

The incorporation of Panasonic's unique AT (auto tracking) mechanism makes slow-motion playback and jogging possible at a speed which can be varied from $-1\times$ to $+2\times$ normal tape speed.

•50× shuttle search

Shuttle search is possible at up to 50× normal tape speed in the forward or reverse direction.

•Simultaneous playback monitoring

Simultaneous playback monitoring of the video, digital audio, time code and CTL signals is possible.

•Automatic editing functions

A full range of editing modes are provided including assemble, insert, spot erase, audio split and variable memory.

•Multi cue points

One hundred cue points can be marked for searches and prerolling.

Operation and maintenance

•Operation panel with direct access

While featuring a multi-functional menu display, the audio level adjustments can be undertaken directly.

•Auto equalizing

The RF parameters are compensated during playback, and the error rate is automatically adjusted to the optimum condition.

•Channel condition monitoring

The error rate is monitored at all times. When the setting is exceeded, an indicator on the front panel lights to warn the operator that the tape is approaching the end of its service life or that the heads are clogged.

•Built-in test signal generator

Color bar signals and other test signals, which come in handy for conducting maintenance and adjustments and for checking the connections, are generated internally.

Serial peripherals

A number of different hi-vision serial digital interface peripherals can be used for the system connections of this unit (AJ-HD2700).

Be sure that the units described belows cannot be used in the 720p system.

•Serial distribution unit (AJ-SDA500)

(Parallel-series conversion is also possible.)

•S/P unit (AJ-HSP500)

•AD converter unit (AJ-HAD500)

•DA converter unit (AJ-HDA500)

•Compact Simple DA unit (AJ-HDA300)

Specifications

Power requirements

| | |
|--------------------|--------------------|
| Power supply: | AC 120 V, 50–60 Hz |
| Power consumption: | 550 W |

General

| | |
|-----------------------|---|
| Operating temperature | 41°F to 104°F (5°C to 40°C) |
| Operating humidity | 10% to 90% (without condensation) |
| Weight | 110 lb (50 kg) |
| Dimensions | 17¼" (W)×11½" (H)×255⅞" (D) [437 (W)×291 (H)×650 (D) mm] (excluding search dial) |
| Recording format | HDD5 format |
| Recording tracks | Digital video: 12 tracks/1 field Digital audio: 12 tracks/4 CH Cue audio/Time code/CTL: 1 track |
| Tape speed | 167.228 mm/sec. |
| Tapes used | ½" metal (L/M) cassettes |
| Recording duration | L=124 min./M=63 min. |
| FF/REW time | Less than 195 sec (L), Less than 115 sec (M) |
| Servo lock time | Less than 1 sec. (standby ON) |
| Tape timer accuracy | ±1 frame (using CTL) |
| Editing accuracy | ±0 frame (using time code) |
| AT playback range | -1-+2 times normal speed |
| Search speed | Max. ±50 times normal speed |

Video system

| | |
|------------------------------------|---|
| TV system | |
| Scanning lines/ Field frequency | 1125/60 (BTA S-001A, SMPTE 240M, SMPTE 274M) 1125/59.94 (BTA S-001A, SMPTE 240M, SMPTE 274M) 750/59.94 or 750/60 (SMPTE 296M) |
| No. of active samples | 1080i/1035i: Y; 1920 samples/line PB/PR; 960 samples/line 720p: Y; 1280 samples/line PB/PR; 640 samples/line |
| No. of active lines | (1) 1035 lines/frame (BTA S-001A, SMPTE 240M) (2) 1080 lines/frame (SMPTE 274M) (3) 720 lines/frame (SMPTE 296M) |
| Quantizing characteristics | 10 bits/sample |
| Image compression system | In-field DCT compression system |
| Channel coding | New 8–14 system |
| Image compression system | In-field compression system |
| Video level adjustments | |
| Output level | +3 dB to -∞, separately for Y and PB/PR |
| Black level | ±100 mV |
| Video phase adjustment | More than ±1/2 H (27ns/step) |
| System phase adjustment | More than ±1/2 H (13.5ns/step) |

Specifications (Continued)

Digital audio

| | |
|----------------------------|--|
| Number of channels | 4 CH |
| Sampling frequency | 48 kHz |
| Quantizing characteristics | 20 bits/sample |
| Frequency response | 20 Hz to 20 kHz ± 0.5 dB |
| Dynamic range | More than 100 dB (1 kHz, emphasis OFF, "A" weighted) |
| Distortion | Less than 0.03% (1 kHz, emphasis OFF, reference level) |
| Crosstalk | Less than -80 dB (1 kHz, between 2 channels) |
| Wow & flutter | Below measurable limits |
| Headroom | 20 dB |
| Input/output level | +8/+4/0/-20 dBm selectable (line input/output) |
| Emphasis | T1=50 μ s/T2=15 μ s (ON/OFF selectable) |
| I/O level adjustment | $-\infty$ to +12 dB |
| Output timing adjustment | Variable from -96 to +16 samples |

Cue audio

| | |
|--------------------------|---|
| Frequency response | 100 Hz to 12 kHz ± 3 dB |
| S/N ratio | More than 44 dB (3% distortion) |
| Distortion | Less than 2% (1 kHz reference signal) |
| Wow & flutter | Less than 0.15% (NAB unweighted) |
| Input/output level | +8/+4/0/-20/-60 (input only) dBm selectable |
| I/O level variable range | $-\infty$ to +12 dB |

Video input/output signals

| | |
|----------------------------------|---|
| HD serial digital input | Complying with BTA S-004A, A-005A, S-006A (SMPTE 291M, 292M & 296M) standard (BNC×2) (including 4 audio channels, LTC, VITC) |
| HD reference input | Analog tri-level sync, ±0.30 V (BNC×2) Loop-through, with 75Ω ON/OFF function |
| HD serial digital output | Complying with BTA S-004A, A-005A, S-006A (SMPTE 291M, 292M & 296M) standard (BNC×2) (including 4 audio channels, LTC, VITC) |
| HD serial digital monitor output | Complying with BTA S-004A, S-005A, S-006A (SMPTE 291M, 292M & 296M) standard (BNC×2) (including 4 audio channels, LTC, VITC), with TC superimposed |

Digital audio input/output signals

| | |
|----------------|---|
| Digital input | CH1/2, CH3/4, AES-3 75Ω, unbalanced, SMPTE 276M (BNC×2) |
| Digital output | CH1/2, CH3/4, AES-3 75Ω, unbalanced, SMPTE 276M, 2-line simultaneous output of signals for 4 digital audio channels [(BNC×2)×2] |

Analog input/output signals

| | |
|-------------------|---|
| Analog input | CH1/2/3/4: Max. +28 dBm, 150Ω/600Ω/high impedance selectable, balance input (XLR×4) |
| Cue line input | Max. +18 dBm, 150Ω/600Ω/high impedance selectable, balance input (XLR×1) |
| Analog output | CH1/2/3/4: Max. +28 dBm, low impedance, balance output (XLR×4) |
| Cue line output | Max. +18 dBm, low impedance, balance output (XLR×1) |
| Monitor output | L/R: Max. +24 dBm, low impedance, balance output (XLR×2) |
| Headphones output | Level variable (1/4" phone×1) |

Video input/output signals (when down-converter board has been installed)

| | |
|---------------------------------|--|
| NTSC reference input | Analog NTSC black burst signal (BNC×1) |
| 525 serial output | <ul style="list-style-type: none"> ●525-line system serial digital output (complying with SMPTE 259M & SMPTE 294M standard) (BNC×2) ●D3/D5/420p serial output switching (4 audio channels) |
| 525 analog video output | Analog NTSC composite (BNC×2) (VIDEO 1 output only, VBS/VB switchable) |
| 525 analog video monitor output | Analog NTSC composite (with TC superimposed) (BNC×1) |

Specifications (Continued)

Other input/output signals

| | |
|------------------|--|
| Time code input | 2.4 V \pm 1.4 Vp-p, 10 k Ω , balanced (XLR \times 1) |
| Time code output | 2.4 Vp-p, low impedance, balanced (XLR \times 1) |
| Waveform output | RF_ENV (CH0, 1, 2, 3) RF_EYE (CH 0, 1, 2, 3)/CTL (R/P, CONF)/TC switching When down-converter board is installed: NTSC analog output/NTSC analog monitor output selectable (BNC \times 1) |
| 525 SYNC output | 525 composite sync (75 Ω , 0.3 V) (BNC \times 1) |
| HD SYNC output | Analog tri-level sync \pm 0.3 V (BNC \times 1) |

Remote signals

| | |
|----------------------|---|
| RS-422A input | RS-422A interface (D-Sub, 9P \times 1) |
| RS-422A output | RS-422A interface (D-Sub, 9P \times 1) |
| RS-422A input/output | RS-422A interface (D-Sub, 9P \times 1) |
| RS-232C | RS-232C interface (D-Sub, 25P \times 1) |
| PARALLEL I/O | Parallel communication (D-Sub, 50P \times 1) |
| V/A control | Video remote control (D-Sub, 15P \times 1) |
| Control panel | For connecting front control panel (20P \times 1) |

Accessory

| |
|---|
| <ul style="list-style-type: none">●Power cord: 1 pc●Extension board: 2 pcs |
|---|

Optional accessories

| |
|--|
| <ul style="list-style-type: none">●Down-converter printed circuit board AJ-DFC2000●Audio printed circuit board AJ-MK30P |
|--|

Front panel

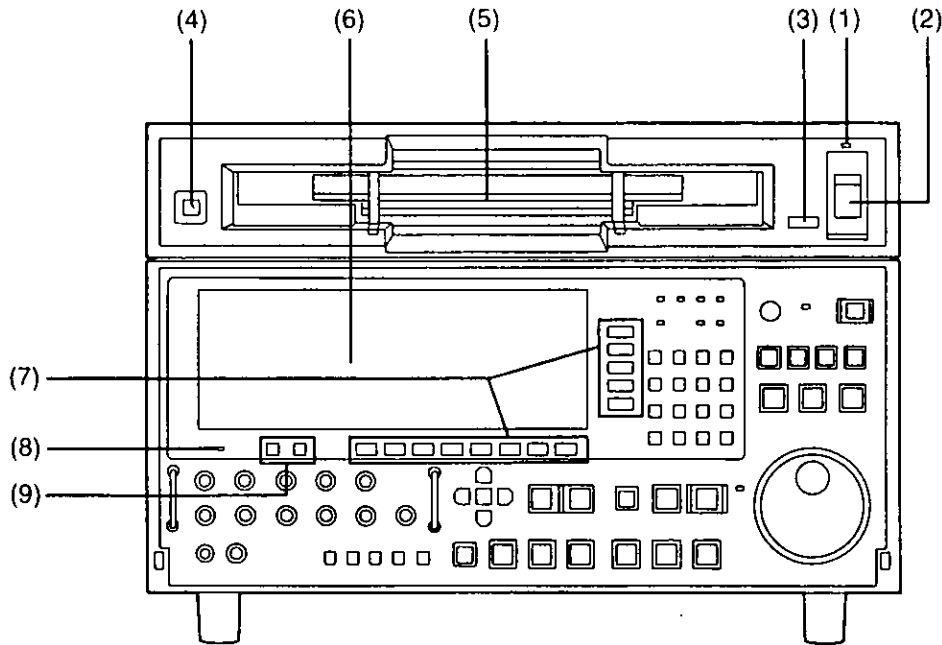

- (1) **POWER lamp** This lights when the power is turned on.
- (2) **POWER switch** When the ON side is pressed, the power is turned on; when the OFF side is pressed, the power is turned off.
- (3) **AUTO OFF lamp** This lights when trouble has occurred in the unit and operation cannot be continued without taking any remedial action.
- (4) **EJECT button** When this button pressed, the cassette tape is ejected.
- (5) **Cassette holder** This is the slot where the 1/2-inch metal cassette tape is loaded.
- (6) **Display panel** The different kinds of data are displayed on this large 640-dot by 200-line display panel.
- (7) **Function keys** Menu function keys F1 to F13 are provided.
- (8) **UNITY lamp** This lights when all the digital audio output signals are in the UNITY state.
- (9) **AUDIO MONITOR L/R selector buttons**
- These buttons are used to select the channel whose signal is to be output to the audio monitor connector and headphone jack.
 - They are used to select the L/R output signals from among the signals of 5 channels (4 digital audio signal channels and 1 cue audio signal channel) which are to be output. Only one signal can be selected for L or R.
 - Each time the L (or R) button is pressed, the selected output L (or R) signal changes: the sequence of change is CH1, CH2, CH3, CH4 and cue.
 - The channel now selected can be monitored by observing the L and R indications on the display panel.
 - L and R are indicated by highlighting the displays corresponding to the channels now selected on the display panel.
 - Default settings: CH1 for L and CH2 for R.

Front panel (Continued)

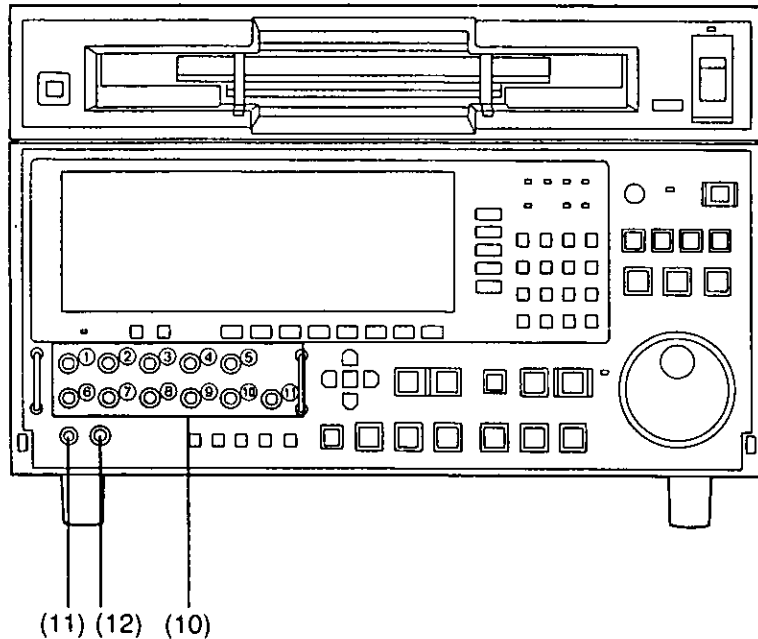

(10) Level adjustment variable resistors (VRs)

- VRs ① to ⑤ on the top row are for adjusting the recording level.
- VRs ⑥ to ⑪ on the bottom row are for adjusting the playback level.
- These VRs can either be pushed in or pulled out. Level adjustment is possible only when they are pulled out.
- When pushed in, the level is returned to its default setting.
- The VRs and the levels they can adjust are shown below:
 - ① Adjusts the digital audio CH1 recording level.
 - ② Adjusts the digital audio CH2 recording level.
 - ③ Adjusts the digital audio CH3 recording level.
 - ④ Adjusts the digital audio CH4 recording level.
 - ⑤ Adjusts the cue audio recording level.
 - ⑥ Adjusts the digital audio CH1 playback level.
 - ⑦ Adjusts the digital audio CH2 playback level.
 - ⑧ Adjusts the digital audio CH3 playback level.
 - ⑨ Adjusts the digital audio CH4 playback level.
 - ⑩ Adjusts the cue audio playback level.
 - ⑪ Master VR
 - This enables all the digital audio playback levels to be adjusted.
 - The audio channels controlled by the master VR can be set on the AUDIO OUT menu. However, this is valid only when the F9 (PB VR) key on the AUDIO OUT menu has been set to COARSE. It does not work if FINE has been selected as the F9 key setting.

(11) Headphone jack

The stereo headphones are connected to this jack.

(12) Headphone VR

- This volume control is used to adjust the headphones output level and monitoring output level.
The headphones output level and monitoring output level are interlinked [when the F6 (A MONI) key on the AUDIO OUT SET UP menu is at the VAR setting].

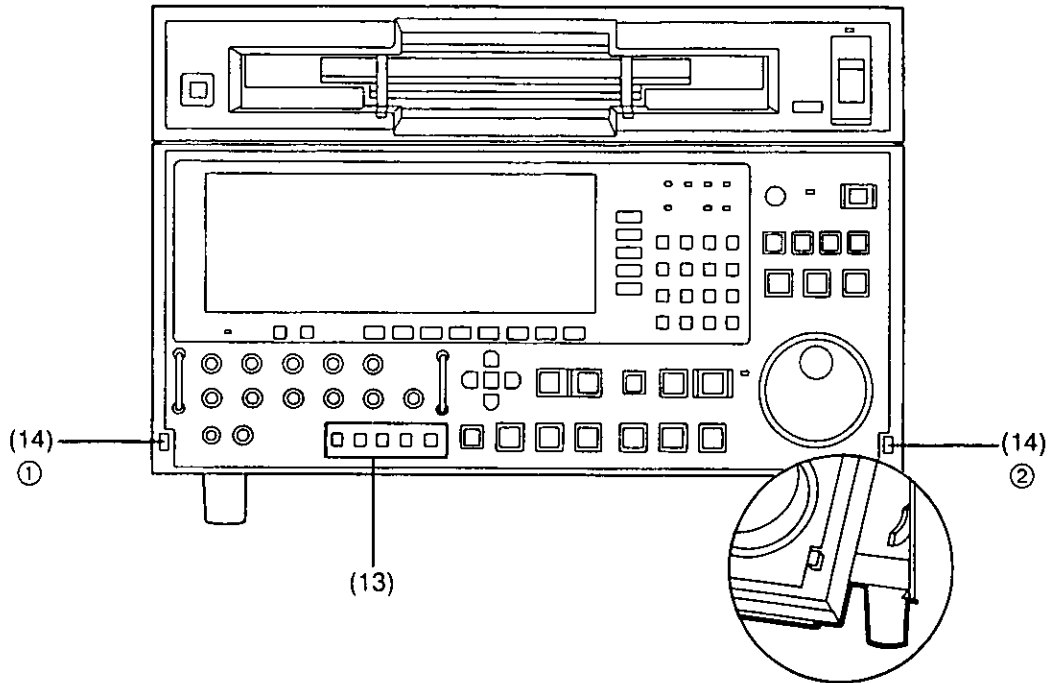

(13) WFM (waveform) buttons

• These buttons enable the signal, which is to be output to the WFM output connector in the connector section, to be selected from among 5 types of output signals (OUT, ENV, EYE, CTL and TC).

OUT: Enables CMPST/MON (monitor output with TC superimposed) to be selected.

(Only when the AJ-DFC2000 down-converter board (optional accessory) has been installed)

ENV: The detection signal of the RF signal played back by video head CH0/1/2/3 is output.

EYE: The RF signal played back by video head CH0/1/2/3 is output.

CTL: The control signal is output.

TC: The time code signal is output.

(14) Panel open/close buttons

• The front panel can be opened and closed by pushing buttons ① and ② provided at the bottom of the front panel.

Front panel (Continued)

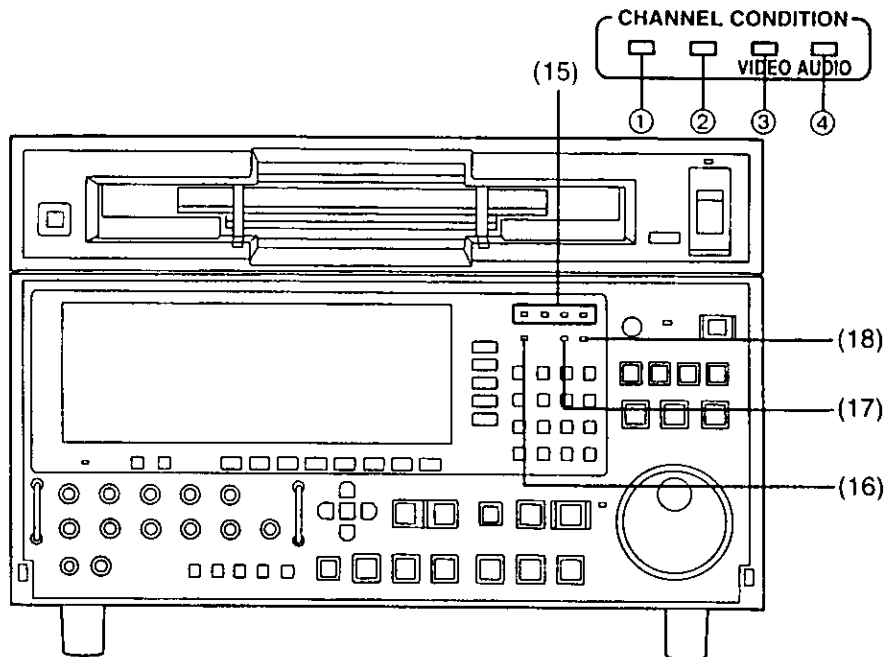

(15) Error display lamps (channel/condition)

- These lamps light in response to the number of errors.
 - ① Lights during normal operation (when the error value is minimal).
 - ② Lights when the number of inner errors has increased.
 - ③ Lights when the number of video outer errors has increased.
 - ④ Lights when the number of audio outer errors has increased.

(16) SYSTEM lamp

- This lights when trouble has occurred in the unit and its operation cannot be guaranteed.

(17) SERVO lamp

- This lights when the servo has locked.

(18) SDI_IN

- ON: The HD SERIAL IN signal has been input properly.
- OFF: The HD SERIAL IN signal has not been input.
- Flashes: An error has occurred in the reception of the HD SERIAL IN signal.

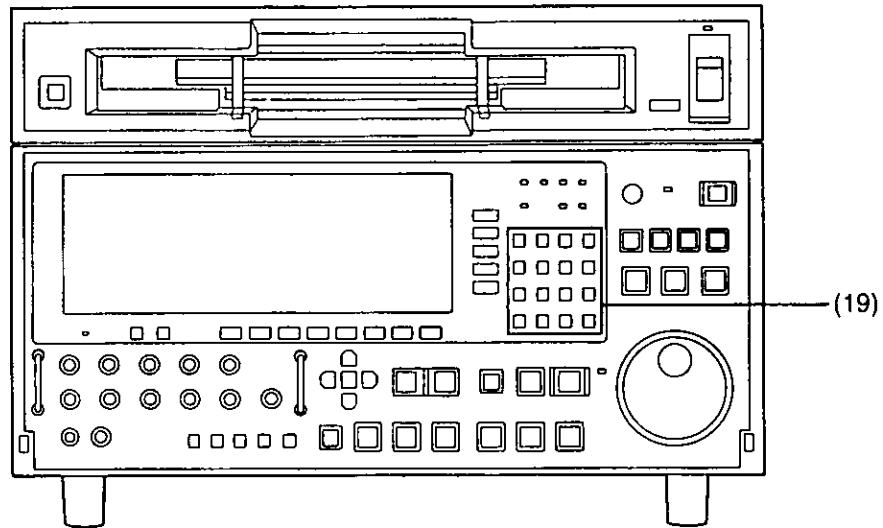

(19) **Number keys (0-9)** • These are used to input numbers.

- **C** Clear key for clearing input data.
- **ENT** For entering the data which have been input.
- **F** Used in combination with other keys.
- **BS** Back space key
- **-, +** Keys for adding and subtracting

Combinations

(The following functions are served by pressing the keys described below together with the F key.)

• **UNITY/VAR**

(F key and 3 key): These keys select UNITY or VAR when the video output signals are adjusted. When UNITY is selected, the UNITY lamp lights.

• **INPUT CHECK**

(F key and BS key):

While these keys are kept depressed, the input signals can be checked.

Front panel (Continued)

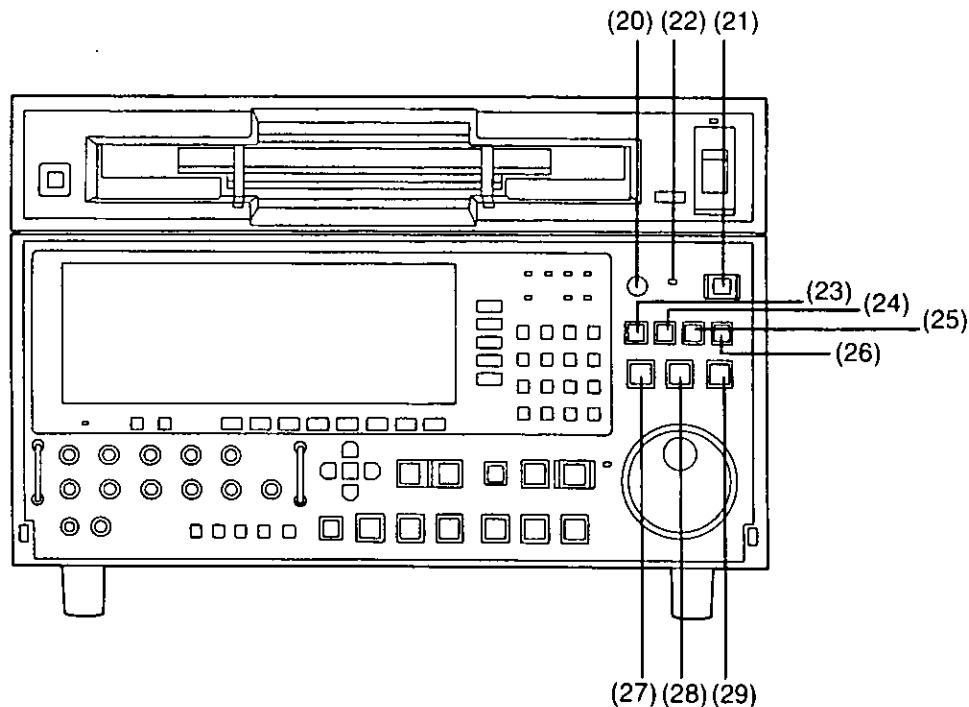

- (20) **ADJUST control** This is used to adjust the levels.
- (21) **CONTROL switch**
- This is used to switch between operation using the controls on the unit's front panel and operation from the remote connector on the rear panel.
 - When it is set to REMOTE, remote control can be exercised over the unit from the remote connector on the rear panel.
 - When it is set to LOCAL, the unit can be operated using the controls on the front panel.
- (22) **REMOTE lamp**
- This lights when the CONTROL switch has been set to REMOTE.
- (23) **HOME button**
- (24) **MULTI CUE button**
- (25) **ASSEMBLE button**
- (26) **INSERT button**
- (27) **JOG button**
- (28) **VAR button**
- (29) **SHTL button**

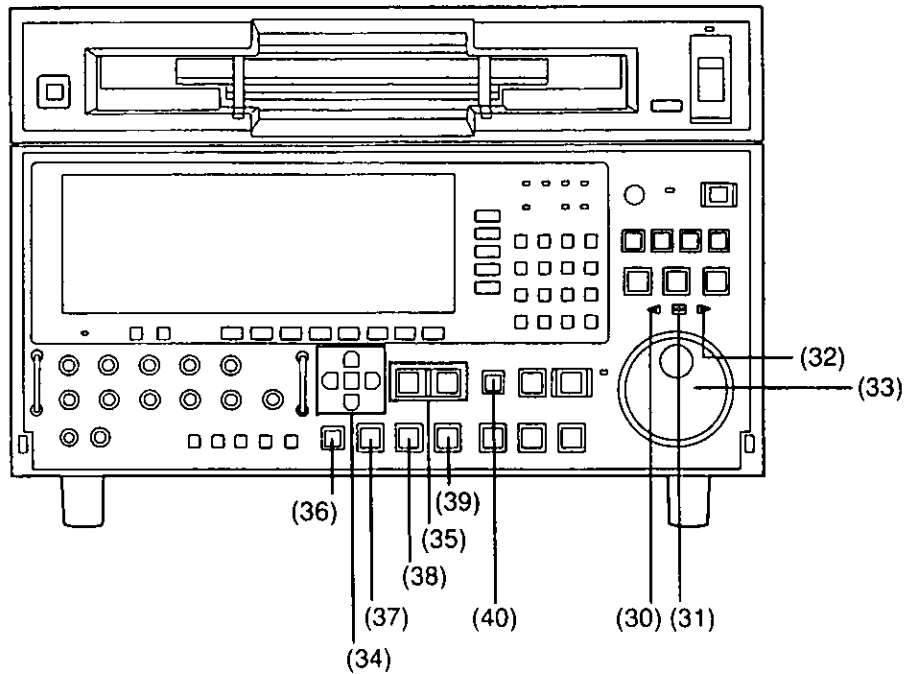

(30) REV lamp

(31) STILL lamp

(32) FWD lamp

(33) SEARCH dial

(34) CURSOR These keys are used to move the cursor on the display. The center key is for displaying the cursor.

(35) ENTRY IN/OUT
button

(36) EXECUTE button This executes the variable memory operation, etc.

(37) REVIEW/PREVIEW
button This previews what has been recorded before editing or reviews the recording after editing.

(38) PREROLL button

(39) SEARCH dial

(40) READY (STAND
BY) button

Front panel (Continued)

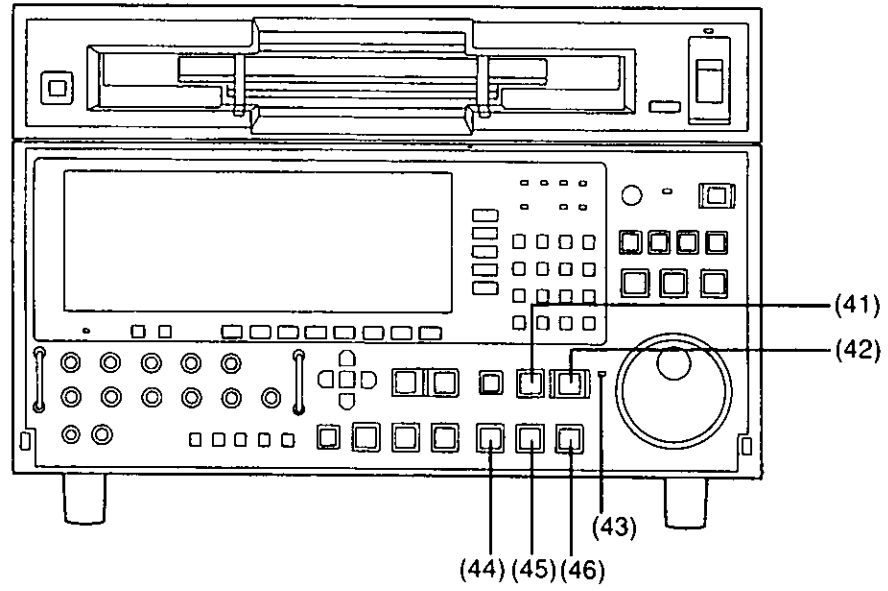

- (41) PLAY button
- (42) REC/EDIT button
- (43) REC INHIBIT lamp
- (44) REW button
- (45) STOP button
- (46) FF button

Connector section

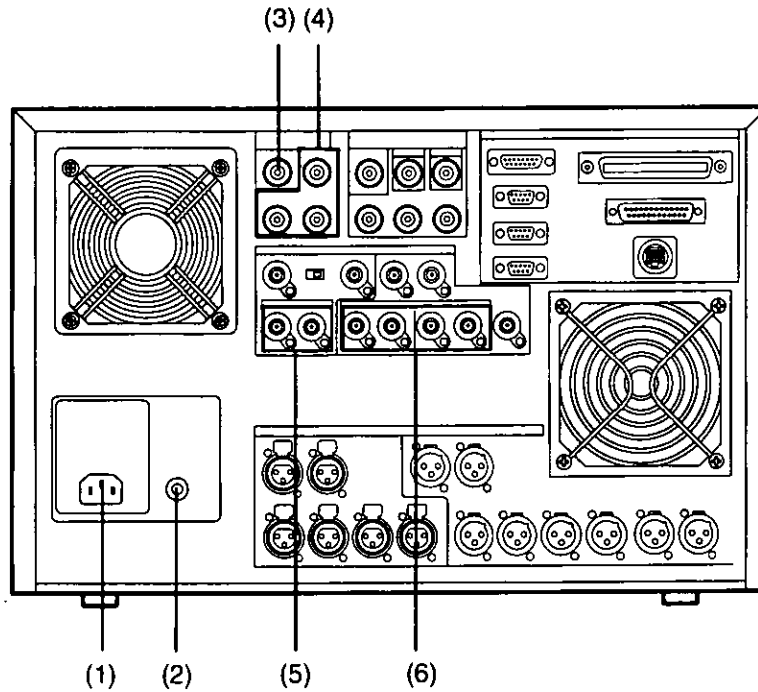

Power supply section

- (1) **AC input socket** This is connected to the power outlet using the power cable supplied.
- (2) **GND (ground) terminal** This unit must be grounded when it is connected to other units.

Digital signal input/output section

- (3) **HD SERIAL IN connector (BNC)** HDTV serial digital signals are input to this connector.
- (4) **HD SERIAL OUT 1, 2 connectors (BNC×2)** HDTV serial digital signals are output from these connectors.
- HD MONITOR OUT (BNC×1)** HD serial digital signals are output from these connectors. The time code can be superimposed.
- (5) **DIGITAL AUDIO IN CH1/2, CH3/4 (BNC×2)** AES standard digital audio signals are input to these connectors.
- (6) **DIGITAL AUDIO OUT CH1/2, CH3/4 (BNC×2)×2** AES standard digital audio signals are output from these connectors. The same signals are output from both sets of connectors.

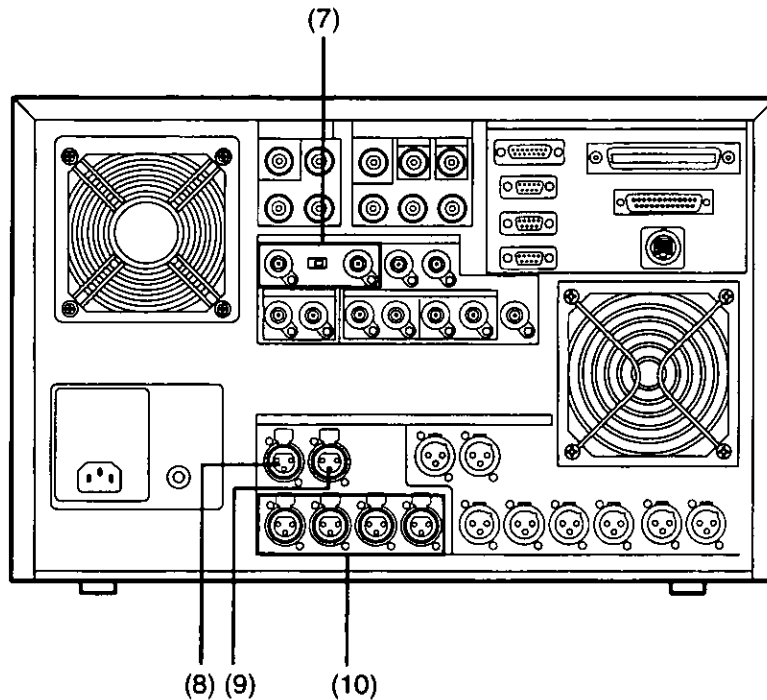

Analog signal input section

- (7) HD REF IN connectors (BNC×2)** The tri-level sync signal is input to these connectors as the reference signal. A loop-through format and a 75Ω termination switch are provided.
- (8) TIME CODE IN connector (XLR 3P)** The time code signals are input to this connector.
- (9) CUE IN connector (XLR 3P)** The audio signals for the analog cue channel are input to this connector.
- (10) AUDIO IN connectors (XLR 3P×4)** The analog audio signals for digital audio channels CH1 to CH4 are input to connectors.

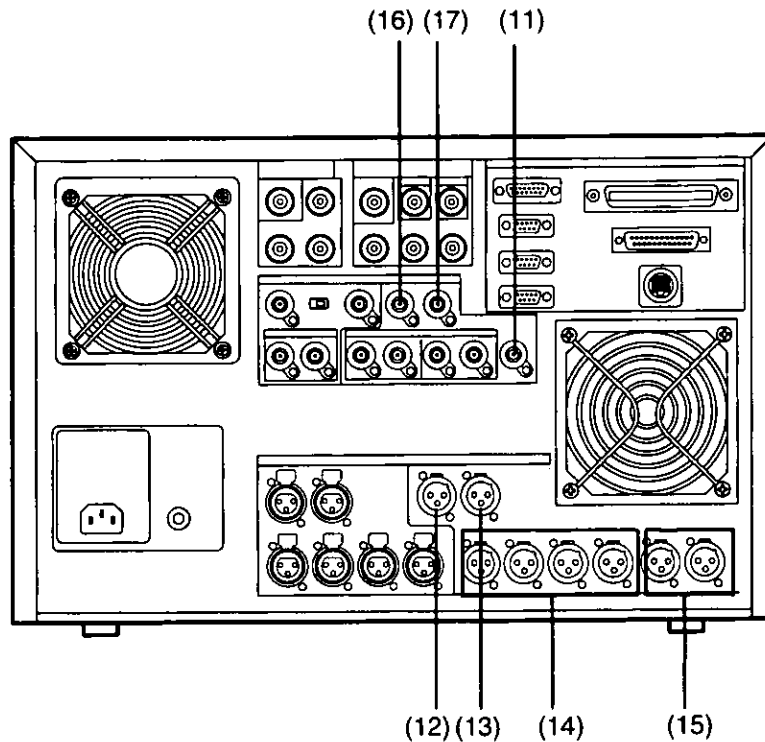

Analog signal output section

- (11) **WFM OUT connector (BNC)** The signals for the waveform monitor are output from this connector.
- (12) **TIME CODE OUT connector (XLR 3P)** The time code signals are output from this connector.
- (13) **CUE OUT connector (XLR 3P)** The audio signals from the analog cue channel are output from this connector.
- (14) **AUDIO OUT connectors (XLR 3P×4)** The analog audio signals for digital audio channels CH1 to CH4 are output from these connectors.
- (15) **MONITOR connectors (XLR 3P×2)** These connectors are for monitoring the sound. The left-channel sound is output from one connector and the right-channel sound from the other. The digital audio signals (CH1/CH2/CH3/CH4) and cue audio signals can be selected.
- (16) **HD SYNC output connector** The HD sync (tri-level sync) signal is output from this connector.
- (17) **525 SYNC output connector (BNC)** The 525 composite sync signal is output from this connector.

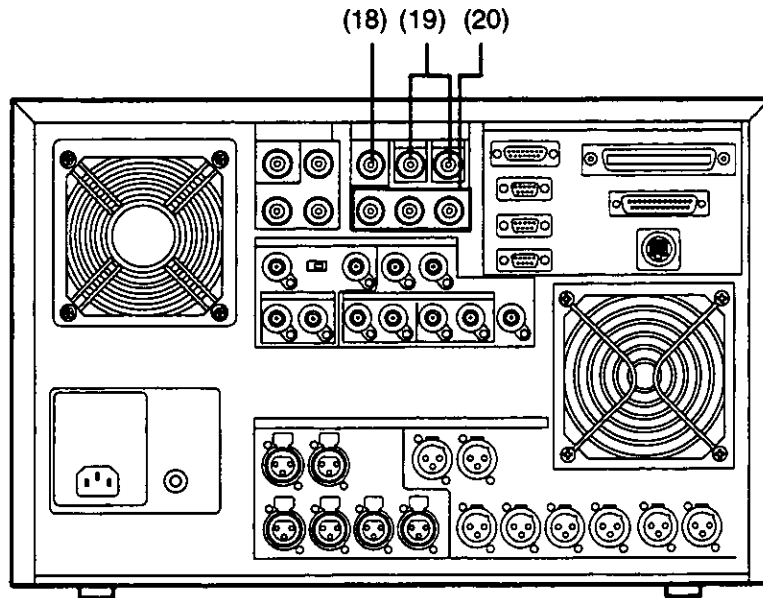

Input/output connectors for down-converter option/PCB

- (18) NTSC REF IN connector (BNC)** The NTSC black burst signal is supplied to this connector to synchronize the down-converter output with this signal. In the 720p system, the NTSC reference input signal must be supplied in order to achieve a synchronized connection in 30 Hz units between this unit and another device.
- (19) SERIAL OUT 1, 2 connectors (BNCx2)** The composite or component serial digital signals are output from these connectors.
- (20) VIDEO OUT 1, 2, 3 connectors (BNCx3)** The analog signals of the down-converter are output from these connectors. VIDEO 1: SYNC OFF can be set on the menu. VIDEO 3: Time code superimposing can be mixed with the analog signal output.

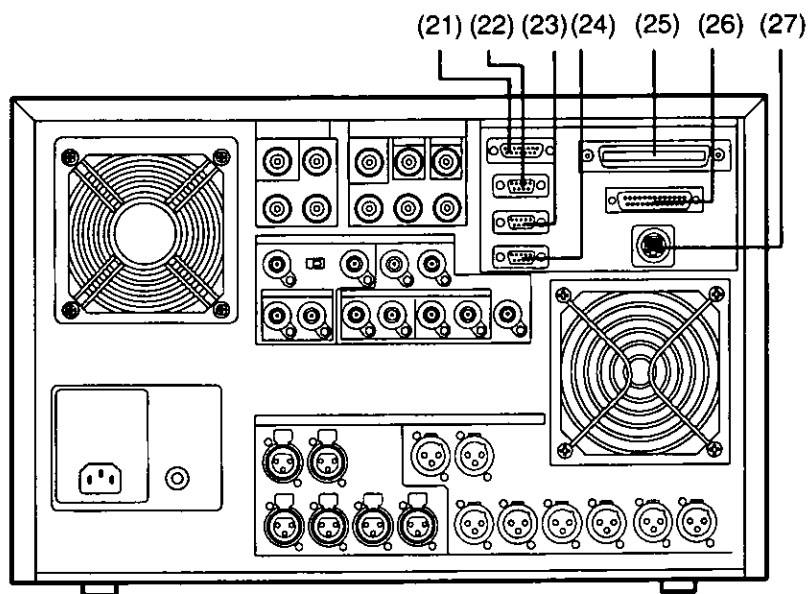

Remote control section

- | | |
|--|--|
| (21) V/A connector (15P) | Encoder remote (AJ-ER50) connector. |
| (22) REMOTE IN connector (RS-422A) (9P) | RS-422A serial remote input connector. |
| (23) REMOTE OUT connector (RS-422A) (9P) | RS-422A serial remote output connector. |
| (24) REMOTE IN/OUT connector (9P) | RS-422A serial remote input/output connector. |
| (25) PARALLEL (I/O) connector (50P) | 50-pin parallel remote connector (mainly for connection with a unit provided by the user). |
| (26) RS-232C connector (25P) | A personal computer or modem is connected to this connector for data transmission. |
| (27) CONTROL PANEL connector (20P) | This is connected to the control panel using the optionally available control panel cable. |

Connections for single unit

Set the front panel CONTROL switch to LOCAL.

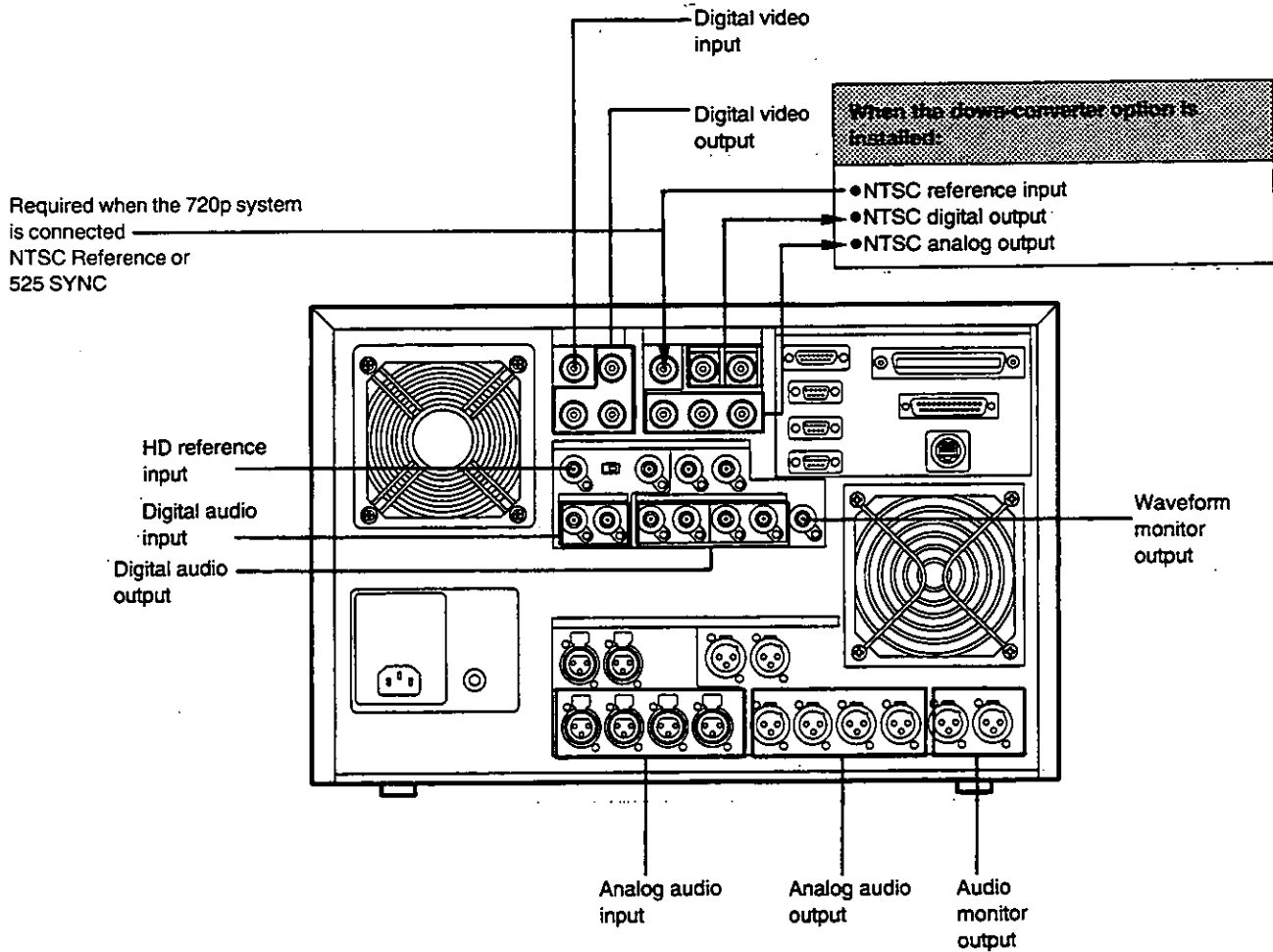

Connections for two units

Source side: Set the front panel CONTROL switch to REMOTE.

Recorder side: Set the front panel CONTROL switch to LOCAL.

For automatic editing using the RS-422A interface, make the selection by pressing the F1 (P-2) key on the INTERFACE SET UP menu.

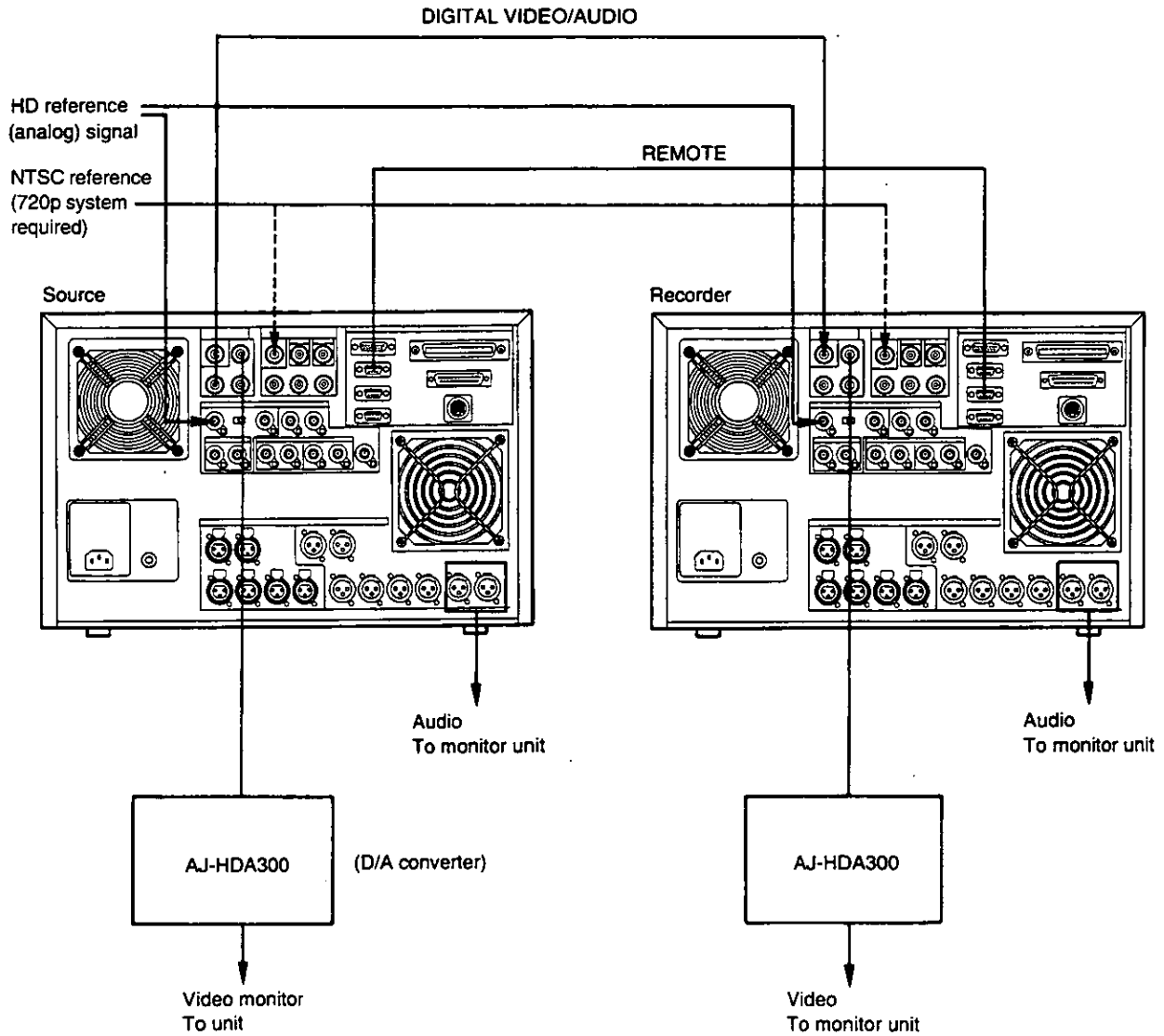

Connections with editing controller

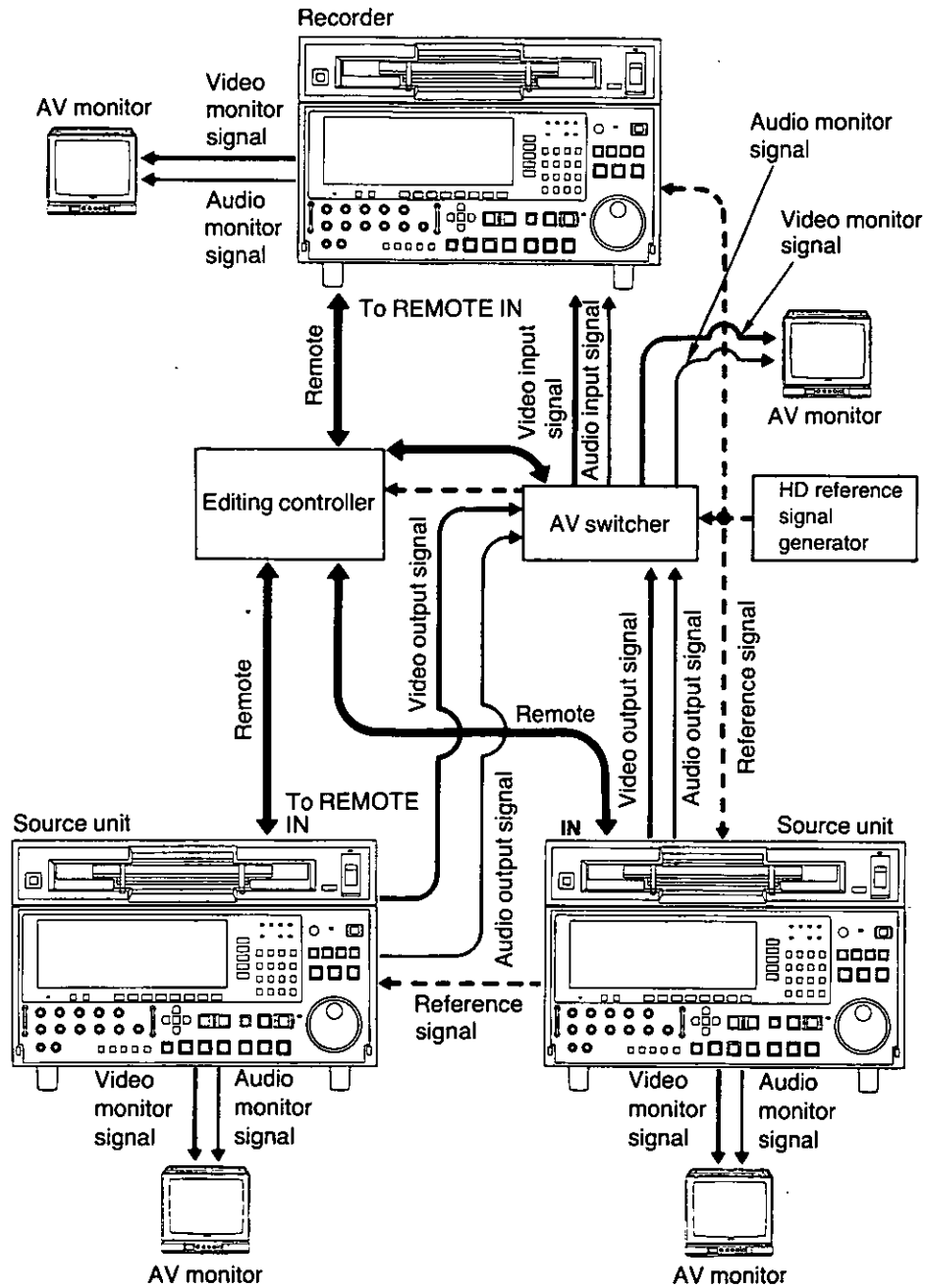

Tapes

Cassette tapes come in 2 sizes:

M (63 minutes)

L (124 minutes)

Align the cassette with the marks on the unit's insertion slot and push it in gently. The tape is automatically loaded.

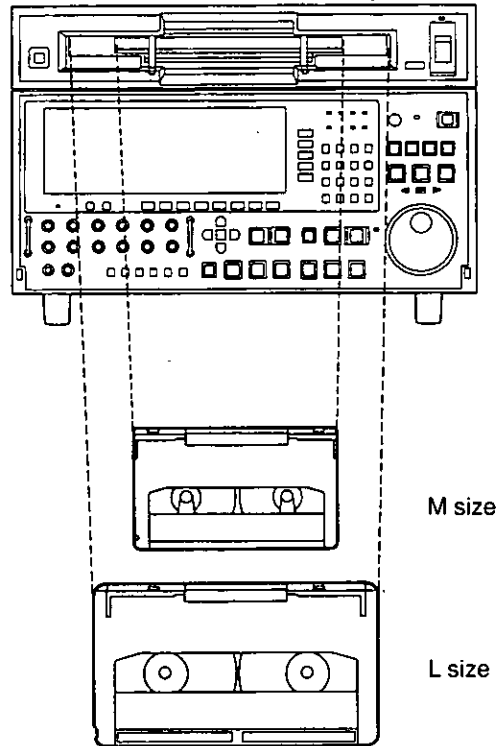

Prohibiting recording on a tape

Disabling recordings

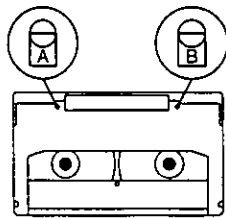

Push the accidental erasure prevention pins down using a screwdriver, turn them 90° counterclockwise to set them to the "up" position. The recording inhibit status is displayed on the MANUAL EDIT SET UP or AUTO EDIT SET UP menu.

Enabling recordings

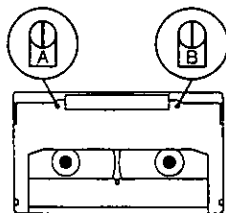

Push the accidental erasure prevention pins down using a screwdriver, turn them 90° clockwise to set them to the "down" position.

Pin A: For inhibiting the recording of any signals

Pin B: For inhibiting the recording of the video and controls signals.

• Pin B functions only when pin A is in the recording enable position.

Recording

Preparations

□ Releasing the recording inhibit mode

- Check that the REC INHIBIT lamp has gone off.



If the lamp does not go off, set the positions of the cassette's accidental erasure prevention pins and the F13 (REC INHIBIT) setting on the HOME menu to the recording enable status.

□ Selecting the input signals and adjusting their levels

- Select the video input signals (INT SG or DIGITAL) on the VIDEO IN menu.
- Select the audio input signals on the AUDIO IN SET UP menu.

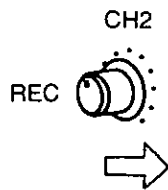

Adjust the levels of the digital audio CH1-CH4 and analog cue audio input signals.

Normally, the adjustment controls are kept at their pushed-in position. The signals will then be recorded at the optimum level.

- To adjust the recording levels, pull out the respective controls and adjust them in such a way that 0 dB is not exceeded for the digital signals and -20 dB is not exceeded for the analog cue signal.



- The OVER display lights when the recording level is too high.

- The level meter display can be selected.

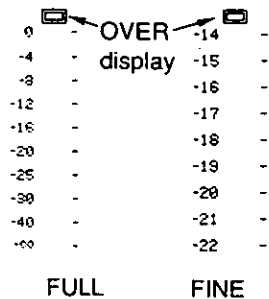

The level meter display can be set to FULL or FINE using the F6 (SCALE) key on the AUDIO IN menu or F6 (SCALE) key on the AUDIO OUT menu.

How to display the menus:

- HOME SET UP menu:

[HOME] → [F8]

- VIDEO IN menu:

[VIDEO IN]

- AUDIO IN menu:

[AUDIO IN]

- AUDIO IN SET UP menu:

[AUDIO IN] → [F8]

- AUDIO OUT menu:

[AUDIO OUT]

Preparations

Setting the time code

- Press the F4 (TC/CTL) key on the HOME menu to select TC.
- Select the internal or external time code and the mode for generating this code on the TC/CHR menu.

Operation

- (1) Press the PLAY button while pressing the REC/EDIT button. Recording now starts.

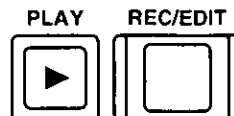

- (2) Recording stops when the STOP button is pressed.
If the JOG, SHTL or VAR button is pressed in place of the STOP button, operation is directly transferred to the mode that corresponds to the button pressed.

How to display the menus:

•HOME menu:

HOME

•TC/CHR menu:

TC/CHR

Recording (Continued)

Simultaneous playback monitoring

Video monitoring

- Set VIDEO during recording to TAPE using the F12 (STATE) key on the VIDEO OUT STATE menu.



Audio monitoring

- Set AUDIO during recording to TAPE using the F12 (STATE) key on the AUDIO OUT SET UP STATE menu.

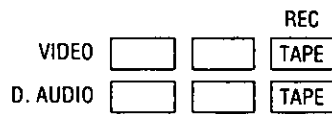

- The digital audio and digital video signals are interlinked at all times. They cannot be set separately.
- It is not possible to play back the analog cue signals simultaneously.
- Simultaneous playback monitoring is not possible if the F1 (OUTPUT) key on the HOME menu is set to EE.
- Even when the state menu setting is EE1 or EE2, simultaneous playback monitoring of both the video and audio signals is possible by setting the F1 (OUTPUT) key on the HOME menu to TAPE.

Checking the input signals

•To monitor the input signals during recording:

- (1) Connect the TV monitor to the serial monitor connector.
- (2) Press the F and BS buttons at the same time.



While these buttons are held down, the video signals can be checked using the serial monitor output connector. Only those audio signals selected by the L and R buttons can be monitored.

How to display the menus:

•STATE menus:

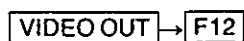

or

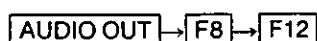

•HOME menu:



•AUDIO IN SET UP menu:

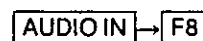

or



Recording digital signals

This flowchart shows the steps taken to record the digital signals which are supplied to the unit from an external digital device.

1. Check the connections.
2. Turn on the power.
3. Insert a recording-enabled cassette.
4. Press the F13 (REC INH) key on the HOME menu to set it to "FREE".

| |
|---------|
| REC INH |
| FREE |

5. Set the field frequency and active lines to match the input signals using the F2 (FLD RATE) and F3 (VIDEO IN ACT LINE) keys of the SET UP SYSTEM menu.

| | |
|----------|----------|
| | VIDEO IN |
| FLD RATE | ACT LINE |
| 60 | 1035 |

6. Set the input signals using the F1 to F4 (CH1 to CH4) keys on the AUDIO IN menu. Select INT SG/ANALOG, AES or SERIAL.

| | | | |
|--------|--------|------|-----|
| CH-1 | CH-2 | CH-3 | CH4 |
| SERIAL | SERIAL | AES | AES |

7. When the input audio signals are to be mixed with the analog cue channel for recording, press the F9 (CUE) key on the AUDIO IN SET UP to set it to "D-MIX", and select the mixing channels using the F10 to F13 (CUE MIX CH1 to CUE MIX CH4) keys.

| |
|-------|
| CUE |
| D-MIX |

How to display the menus:

•SET UP SYSTEM menu:

SET UP → F4

•AUDIO IN SET UP menu:

AUDIO IN → F8

or

SET UP → F6

Recording digital signals (Continued)

- Adjust the audio input level using the recording level control.



- When the time code is to be recorded, proceed with the time code-related settings on the TC/CHR menu.
- To input the time code default value as desired, press the cursor center key on the HOME menu and set the value.
- When the reference for the signals to be recorded has been established, press the REC/EDIT and PLAY buttons together. Recording now commences.
- To stop recording at any time, press the STOP button.

How to display the menus:

•TC/CHR menu:

TC/CHR

•HOME menu:

HOME

Playback

Operation



- (1) Press the PLAY button.
Playback now starts.

- (2) Playback stops when the STOP button is pressed.
If the JOG, SHTL, VAR, FF or REW button is pressed in place of the STOP button, operation is directly transferred to the mode that corresponds to the button pressed.

□ Monitoring the audio signals

- Select the audio channel whose signals are to be output from the AUDIO MONITOR L/R connectors or HEADPHONES jack using the L and R buttons.

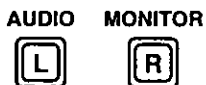

□ Adjusting the audio level

Adjust the playback level of the digital audio CH1–CH4 signals and analog cue audio signals.

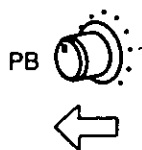

To adjust the audio signal levels, pull out the respective controls and adjust them. The adjustment range is $-\infty$ to +12 dB both for the digital audio signals and analog cue signal.

- To adjust the digital audio signal levels altogether, pull out the MASTER control and adjust. (However, this is valid only when the F9 (PB VR) key on the AUDIO OUT menu has been set to COARSE.)



- The level meter display can be set to FULL or FINE.

| | | | |
|------|---|------|---|
| 0 | - | -14 | - |
| -4 | - | -15 | - |
| -8 | - | -16 | - |
| -12 | - | -17 | - |
| -16 | - | -18 | - |
| -20 | - | -19 | - |
| -25 | - | -20 | - |
| -30 | - | -21 | - |
| -40 | - | -22 | - |
| -∞ | - | | |
| FULL | | FINE | |

Fine adjustment is possible by setting the F6 (SCALE) key on the AUDIO IN menu or F6 (SCALE) key on the AUDIO OUT menu to "FINE".

How to display the menus:

• AUDIO OUT menu:

AUDIO OUT

• AUDIO IN menu:

AUDIO IN

Basic operations

□ Stop

Press the STOP button.
The tape stops traveling.



- In order to protect the tape, the tape tension is automatically released (a process called "losing") when the time selected by the F12 (STILL) key on the HOME SET UP menu has elapsed. The READY lamp flashes.
- Furthermore, the READY OFF mode is automatically established when the time selected by the F13 (STBY OFF) key on the HOME SET UP menu has elapsed. The READY lamp goes off and the STOP lamp lights. [Refer to the READY (standby) mode section on this page.]

□ FF/REW

Press the FF or REW button.

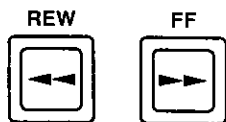

- The tape is now fast forwarded or rewound at approximately 50x the normal playback speed.
- In order to protect the tape, the speed is reduced as the tape-end is approached.
- Use the F5 (FF/REW MAX SP) key on the INTERFACE SET UP menu to make changes to the fast forward or rewind speed.

□ READY (standby)

- When the READY lamp is lighted, it means that the unit is in the READY ON status.



The READY OFF mode is automatically established when the time selected by the F13 (STBY OFF) key on the HOME SET UP menu has elapsed in the losing mode. (Refer to the STOP mode section on this page.)

- When the READY lamp is off, it means that the unit is in the READY OFF status.

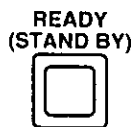

Two modes are associated with this mode.

- (1) Drum rotation stop mode with tension release Set the F6 (TAPE MODE) key on the HOME SET UP menu to HD.STOP.
- (2) Half loading mode Set the F6 key on the HOME SET UP menu to HLF LOAD.

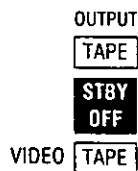

- When the F1 (OUTPUT) key on the HOME menu and STBY OFF VIDEO on the STATE menu are set to TAPE, the memory screen (still picture) is output to the monitor screen when the F1 (STBY OFF) key on the STATE menu is set to FREEZE, and the monitor screen is muted when it is set to MUTE.

How to display the menus:

- HOME SET UP menu:

HOME → F8

- INTERFACE SET UP menu:

SET UP → F8

- HOME menu:

HOME

- STATE menu:

VIDEO OUT → F12

or

AUDIO OUT → F8 → F12

□ Jog

JOG



(1) The unit is placed in the JOG mode when the JOG button is pressed and its lamp lights.

(2) Turn the search dial.

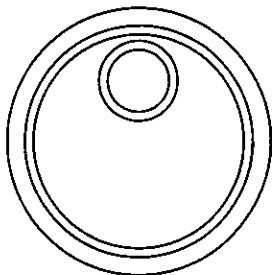

- When the dial rotation is stopped, the unit is placed in the still-picture (STILL) mode.
- The tape protection mode is established after the still-picture retention time has elapsed. [This time can be set using the F12 (STILL) key on the HOME SET UP menu and ADJUST control.]
- The tape speed changes depending on the speed at which the dial is turned.
- The tape speed ranges from $-2\times$ to $+2\times$ the normal tape speed. When it ranges from $-1\times$ to $+2\times$ the normal tape speed, the audio signals for all the channels are output from the AUDIO OUT connectors.

(3) When the STOP, FF, REW, PLAY, SHTL or VAR button is pressed, operation is directly transferred to the mode that corresponds to the button pressed.

□ Shuttle (SHTL)

SHTL



(1) The unit is placed in the shuttle mode when the SHTL button is pressed and its lamp lights.

(2) Turn the search dial.

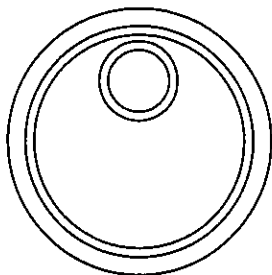

- The tape speed changes depending on the angle to which the dial is turned.
- The tape speed is displayed on the search indicator.
- The tape speed can be varied up to a maximum of $\pm 50\times$ the normal tape speed.
- The maximum speed can be set by pressing the F6 (SHTL MAX SP) key on the PANEL SET UP menu.

(3) When the STOP, FF, REW, PLAY, JOG or VAR button is pressed, operation is directly transferred to the mode that corresponds to the button pressed.

How to display the menus:

• HOME SET UP menu:

HOME → F8

• PANEL SET UP menu:

SET UP → F11

Basic operations (Continued)

□ Variable (VAR)

The variable mode is a low-speed version of the shuttle mode. This operation may be initiated from the STOP or PLAY mode or during normal recording.



(1) The unit is placed in the variable mode when the VAR button is pressed and its lamp lights.

(2) Turn the search dial.

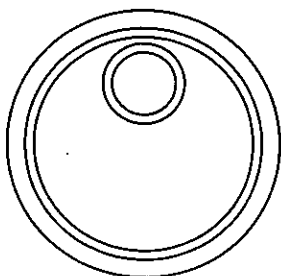

- The tape speed changes depending on the angle to which the dial is turned, and it is displayed on the search indicator.
- The tape protection mode is established after the still-picture retention time has elapsed. [This time can be set using the F12 (STILL) key on the HOME SET UP menu and ADJUST control.]
- Turning the dial enables shuttle operations across a range from $-1\times$ to $+2\times$ the normal tape speed. The audio signals for all the channels are output from the AUDIO OUT connectors.
- The maximum speed can be set by pressing the F12 (VAR MAX SP) key on the PANEL SET UP menu.

(3) When the STOP, FF, REW, PLAY, JOG or SHTL button is pressed, operation is directly transferred to the mode that corresponds to the button pressed.

• Preset variable mode

When the variable speed is preset, playback starts at the set speed when the VAR button is pressed.

(1) Set the desired speed by turning the search dial. The tape speed changes depending on the angle to which the dial is turned. The speed is displayed on the search indicator.

(2) Press the VAR button. (The VAR lamp lights.) Playback starts at the set speed.

(3) To release the preset variable mode, turn the search dial. The normal variable mode is established.

- The preset variable mode can be operated only in the STOP or PLAY mode or during normal recording.

How to display the menus:

• PANEL SET UP menu:

SET UP → F11

• HOME SET UP menu:

HOME → F8

□ Tape speed override (TSO) function

This is a function for finely adjusting the normal playback speed in a $\pm 15\%$ range.



- (1) Press the PLAY button. Normal playback starts.
- (2) Turn the search dial while pressing the PLAY button. Depending on the angle to which the search dial is turned, the tape speed changes. The speed is displayed on the search indicator.
- (3) To return to normal playback, release the PLAY button.

□ Cue

This function sets any point on the tape for preroll and search operations.

- (1) Press the cursor center key to display the cursor. The time code value is highlighted.

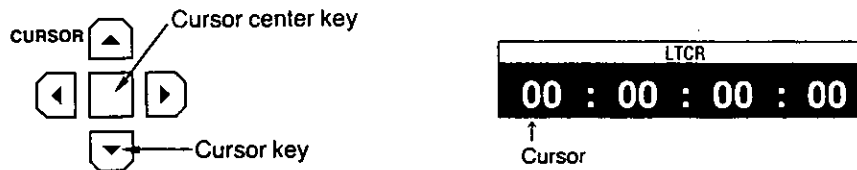

- (2) Move the cursor to the CUE TIME display section using the cursor key (\blacktriangledown). The cue display section is highlighted.

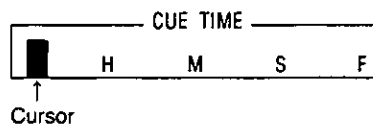

- (3) Press the cursor center key again, and the cursor will change to a bar cursor. Input the cue point using the number keys.

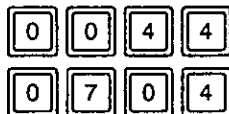

- Cue points can also be entered by pressing the ENTRY IN (or ENTRY OUT) button. In this case, the time data of the current tape position will be input.

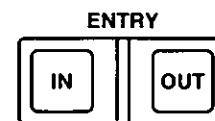
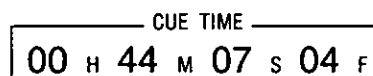

- (4) Press the ENT key.
The cursor is now cleared.
- (5) Press the PREROLL or SEARCH button.

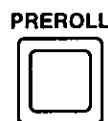

- When the PREROLL button is pressed, the cue-up operation is commenced and the tape stops at the preroll point (the point which is the preroll time before the cue point).
- If the SEARCH button is pressed, the tape is stops at the cue point.

Basic operations (Continued)

□ Cue (continued)

| | |
|------------------|-----------------|
| R IN 00:41:07:04 | OUT 00:41:01:15 |
| | |
| P IN | |

• Follow the steps given below to search using the INSERT/ASSEMBLE AUTO EDIT menu.

- (1) Bring the cursor to the edit point to be searched.
- (2) Press the SEARCH button.

• Correcting a cue point

- (1) Move the cursor to the place which is to be corrected.

| | | | | | | |
|----------|---|---|---|--------|----|--------|
| CUE TIME | | | | | | |
| 00 | H | 4 | 1 | M | 07 | S 04 F |
| | | | ↑ | | | |
| | | | | Cursor | | |

- (2) Input the new value using the number keys.

| | | | | | | |
|----------|---|---|---|---|----|--------|
| CUE TIME | | | | | | |
| 00 | H | 4 | 4 | M | 07 | S 04 F |

- (3) Press the ENT key.

• Cue points cannot be cleared.

How to display the menus:

• INSERT/ASSEMBLE AUTO EDIT menu:

| |
|--------|
| INSERT |
|--------|

 or

| |
|----------|
| ASSEMBLE |
|----------|

Manual editing

Manual editing is a method used for editing which does not involve the entry of edit points (IN/OUT points).

1. Check the connections.
2. Switch on the power.
3. Insert the cassette to be edited.
4. Press the F13 (REC INH) key on the HOME menu to set it to FREE or NRML.REC.

REC INH
FREE

5. Select and adjust the input signals.
6. To record the time code, proceed with the time code-related settings on the TC/CHR menu.
7. To input the desired default value for the time code, press the cursor center key on the HOME menu and set it to the desired value.
8. Press the ASSEMBLE or INSERT button to display the INSERT/ASSEMBLE EDIT menu.
9. Press the F12 key on the INSERT/ASSEMBLE EDIT menu to set it to MANUAL EDIT, display the MANUAL EDIT menu, and highlight the F9 (INSERT/ASSEMBLE) key.

MANUAL
EDIT

10. When insert editing was selected in step 8 by pressing the INSERT button, press the F1 (VIDEO) to F7 (TC) keys on the INSERT MANUAL EDIT menu, and select the channels to be edited.
11. Set the editing timing using the F1 (TIMING) key on the INSERT/ASSEMBLE MANUAL EDIT SET UP menu.

TIMING

F2

12. Search the edit start (IN) point and set the picture to the still mode.
13. Press the PREROLL button if preroll is required.
14. Input the editing source.
15. Press the PLAY button to place the unit in the playback mode.
16. Press the REC/EDIT button at the edit start (IN) point. Editing now commences.
17. To conclude editing, press the STOP or REC/EDIT button.

How to display the menus:

•HOME SET UP menu:

HOME → F8

•TC/CHR menu:

TC/CHR

•HOME menu:

HOME

Manual audio cross editing

Below is a flowchart showing the steps taken for editing in which audio signals are cross-faded (while the preceding playback sound is being faded out, the player sound is faded in) in the manual edit mode.

1. Prepare for manual editing by referring to steps 1 to 13 in the manual editing flowchart.
2. Set the F13 (MODE) key on the INSERT/ASSEMBLE MANUAL EDIT SET UP menu to XFADE.

MODE
X FADE

3. Use the F12 (FD TIME) key on the INSERT/ASSEMBLE MANUAL EDIT SET UP menu to set the fade time.

MODE FD TIME
X FADE 20

4. Refer to steps 14 to 18 of manual editing, and proceed with editing.
 - For audio V fading, set the F13 (MODE) key on the INSERT/ASSEMBLE MANUAL EDIT SET UP menu to VFADE.
 - If audio mixing recording has been selected [F6 (CH-MIX) key set to ON on the AUDIO IN SET UP menu], cut editing will occur automatically.

How to display the menus:

•INSERT/ASSEMBLE MANUAL EDIT SET UP menu:

INSERT or ASSEMBLE → F8

Automatic insert/assemble editing

Below is a flowchart showing the steps taken for automatic insert editing or automatic assemble editing using two digital VTRs.

1. Check the connections.
2. Switch on the power to both the recorder and player.
3. Insert the cassettes required for editing into the VTRs.
4. Set the REMOTE switch on the player to REMOTE.

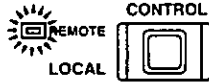

5. Set the REMOTE switch on the recorder to LOCAL.



6. Set the F3 (W/PLYR) key on the recorder's INSERT/ASSEMBLE AUTO EDIT menu to ON.



7. Set the F1 (P-2) key on the recorder's INTERFACE SET UP menu to MODE-1.
Set the RS-422A control mode for each VTR depending on the player/recorder connections.
[Refer to the F1 (P-2) key on the INTERFACE SET UP menu.]



8. Set the F13 (REC INH) key on the HOME menu to FREE or NRML.REC.



Recorder operations



9. Select and adjust the input signals.
10. To record the time code, proceed with the time code-related settings on the TC/CHR menu.
11. To input the desired default value for the time code, press the cursor center key on the HOME menu and set it to the desired value.

How to display the menus:

• INSERT/ASSEMBLE AUTO EDIT SET UP menu:

INSERT or **ASSEMBLE** → **F8**

• INTERFACE SET UP menu:

SET UP → **F10**

• HOME menu:

HOME

• HOME SET UP menu:

HOME → **F8**

• TC/CHR menu:

TC/CHR

Automatic insert/assemble editing (Continued)

12. Press the ASSEMBLE or INSERT button to display the INSERT/ASSEMBLE EDIT menu, and then set the F12 key to AUTO EDIT. When the F9 (INSERT/ASSEMBLE) key is highlighted, the editing mode is established.
13. When insert editing was selected in step 12 by pressing the INSERT button, press the F13 (CH SELECT) key on the INSERT AUTO EDIT menu, and select the channels to be edited on the editing channel selection menu.
14. Enter the edit points on the INSERT/ASSEMBLE AUTO EDIT menu. Enter 3 points among the player's IN and OUT points and the recorder's IN and OUT points.
15. Set the recording inhibit mode on the INSERT/ASSEMBLE AUTO EDIT SET UP menu. (For assemble editing, release recording inhibit for all the channels.)
16. Proceed with the settings on the AUTO EDIT SET UP menu.
17. Press the PREVIEW button to preview.
18. When the REC/EDIT button is pressed, automatic editing commences.
19. To review what has been edited, press the REVIEW button upon completion of the editing.

How to display the
menus:

• INSERT/ASSEMBLE AUTO EDIT SET UP menu:

INSERT or **ASSEMBLE** → **F8**

Spot erase editing

Below is a flowchart showing the editing steps taken for partially erasing the signals which have been recorded in the digital audio channels.

1. Insert the cassette to be edited into the VTR.
2. Set the F13 (REC INH) key on the HOME menu to FREE or NRML.REC.
3. Press the INSERT button to display the INSERT AUTO EDIT menu. Set the F11 (SPOT ERS) key on this menu to ON.

SPOT ERS
ON

4. Select the digital audio channels to be erased on the "Edit channel selection menu" of the INSERT AUTO EDIT menu.
5. Enter the erase start and erase end points.
6. Press the PREVIEW button to preview.
7. When the REC/EDIT button is pressed, automatic editing commences.
8. To review what has been edited, press the REVIEW button upon completion of the editing.

Audio split editing

Below is a flowchart showing the steps taken for separately entering the audio and video edit point positions for automatic editing.

1. Press the INSERT button to display the INSERT AUTO EDIT menu.



2. Press the F10 (SPLIT) key on the INSERT AUTO EDIT menu to set it to ON.



3. Refer to the flowchart of the automatic insert editing operation, and proceed to enter the video edit points.
4. Enter the audio edit points.
5. Press the PREVIEW button to preview.
6. When the REC/EDIT button is pressed, automatic editing commences.
7. To review what has been edited, press the REVIEW button upon completion of the editing.

Edit OUT point preview

Previewing the automatic insert editing OUT point (when audio split is OFF)

This flowchart shows the steps taken to preview the automatic insert editing OUT point. The OUT point for automatic assemble editing cannot be previewed.

1. Press the INSERT button to display the INSERT AUTO EDIT menu.
2. Using the automatic insert editing flowchart as a reference, register the VIDEO OUT point.
3. Press the EXECUTE and PREVIEW/REVIEW buttons together to preview the OUT point.

Previewing the automatic insert editing OUT point (when audio split is ON)

This flowchart shows the steps taken to preview the automatic insert editing (audio split) OUT point. The OUT point for automatic assemble editing cannot be previewed.

1. Press the INSERT button to display the INSERT AUTO EDIT menu.
2. Press the F10 (SPLIT) key on the INSERT AUTO EDIT menu and set it to ON.



3. Using the automatic insert editing flowchart as a reference, register the VIDEO OUT point.
4. Register the audio edit points.
5. **To preview the VIDEO OUT point:**
 1. Use the cursor keys to move the cursor to the places where the VIDEO IN and OUT points were registered.
 2. Press the EXECUTE and PREVIEW/REVIEW buttons together to preview the VIDEO OUT point.
6. **To preview the AUDIO OUT point:**
 1. Use the cursor keys to move the cursor to the places where the AUDIO IN and OUT points were registered.
 2. Press the EXECUTE and PREVIEW/REVIEW buttons together to preview the AUDIO OUT point.
7. **To preview the OUT point without moving the cursor to where the IN and OUT points were registered:**

When a cursor is not available, the preview operation is commenced from the point 10 seconds before the external OUT point. Now press the EXECUTE and PREVIEW/REVIEW buttons together to preview the OUT point.

Switching on the power

Switch on the power.

▼
The HOME menu appears on the display.

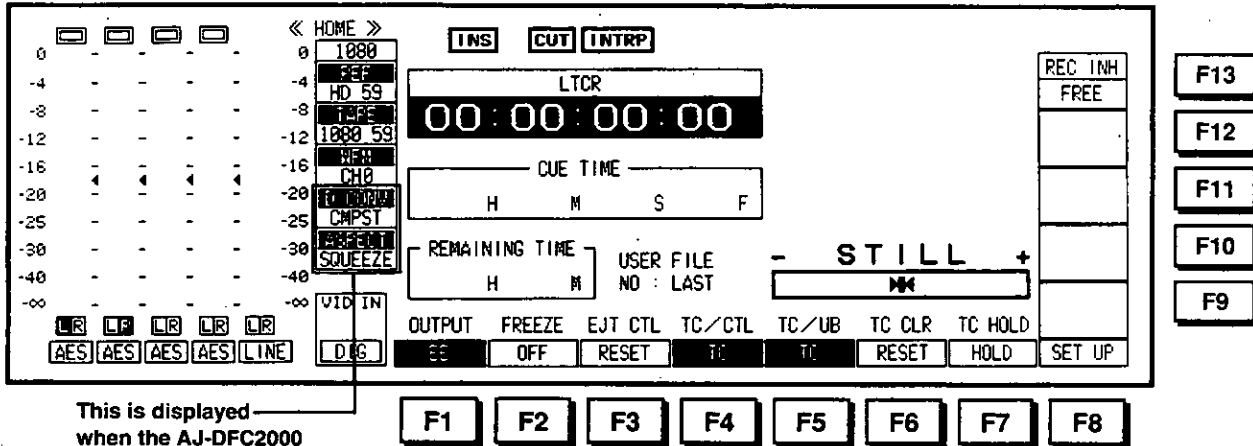

This unit comes with the menus each tailored for a specific application, and the actual steps taken differ for each menu screen.

When a menu is selected with the menu selector button, the details shown on the display change, and the function keys (F1–F13) serve their purpose in accordance with the individual menu selected.

SET UP menus are provided in order to set those functions on the menus which are not used very frequently.

The basic menu of this unit is the HOME menu. When the unit's power is switched on, the HOME menu automatically appears on the display. (The IC CARD menu will appear automatically if the IC card has been inserted.)

HOME menu displays

□ Audio signal display section

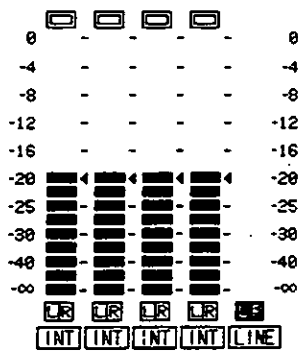

Adjust the levels of the audio input signals using the REC level controls in the audio adjustment section.
Adjust the playback output levels of the audio signals using the PB level controls.

Select the audio channels whose signals are to be output from the AUDIO MONITOR L/R connectors and HEADPHONES jack using the L/R buttons.

Display the type of input signal for each channel. Use the F1 (CH-1) to F4 (CH-4) keys and F9 (CUE) key on the AUDIO IN SET UP menu to select the signals.

- ANA: Signal from ANALOG INPUT connector.
- CH1 to CH-4 AES: Signal from DIGITAL AUDIO INPUT connector.
- SER: Signal from serial V/A input connector.
- INT: Signal from internal signal generator.
- LINE: Signal from CUE IN connector.
- CUE MIX: Signals which have been selected from among the CH1 to CH4 signals by the CUE MIX setting.
- AUTO: Always available for digital channel back-up.

□ Display lamps



1035/1080/720p:
This indicates the number of active recording lines which was set by F1 (1125/720p) or F3 (VIDEO IN ACT LINE) key on the SET UP SYSTEM menu.

REF/IN_FLD:
This indicates the status of the output reference signal below the REF display. In the input check status (which is established by pressing the F and BS buttons together), the REF display changes to IN_FLD, and the status of the recording reference signal appears below this display.

<Displays and what they signify>

- HD 60:** The HD_REF input has been selected as the reference; the field frequency is 60 Hz.
- HD 59:** The HD_REF input has been selected as the reference; the field frequency is 59.94 Hz.
- IN 60:** The HD serial input has been selected as the reference; the field frequency is 60 Hz.
- IN 59:** The HD serial input has been selected as the reference; the field frequency is 59.94 Hz.
- INT 60:** The internal generator's signal (60 Hz) has been selected as the reference.
- INT 59:** The internal generator's signal (59.94 Hz) has been selected as the reference.
- NTSC 59:** The NTSC_REF input has been selected as the reference; the field frequency is 59.94 Hz.
- INT 59_N:** NTSC REF has been selected by the OUT REF setting (see page 60). The internal oscillator (59.94 Hz) is used since the NTSC REF signal has not been input.

How to display the menus:

●AUDIO IN SET UP menu:

AUDIO IN → F8

or

SET UP → F6

●SET UP SYSTEM menu:

SET UP → F4

HOME menu displays (Continued)



TAPE/1035_60:

This indicates the format with which the tape playback signals were recorded on the tape.

1035_60: This denotes that the tape was recorded using the Hi-vision (60 Hz) format with 1035 active lines.

1035_59: This denotes that the tape was recorded using the Hi-vision (59.94 Hz) format with 1035 active lines.

1080_60: This denotes that the tape was recorded using the Hi-vision (60 Hz) format with 1080 active lines.

1080_59: This denotes that the tape was recorded using the Hi-vision (59.94 Hz) format with 1080 active lines.

720_60: This denotes that the tape was recorded using the Hi-Vision (60 Hz) format with 720 active lines.

720_59: This denotes that the tape was recorded using the Hi-Vision (59.94 Hz) format with 720 active lines.

D3: This denotes a tape recorded using the D3 format.

13.5M: This denotes a tape recorded using the D5 (13.5 MHz) format.

18M: This denotes a tape recorded using the D5 (18 MHz) format.

420P: This denotes a tape recorded using the ED processor (AJ-EDP580).

Note: The unit's current recording format is displayed when a tape has not been loaded.

WFM:

This indicates the waveform output.

When the ENV, EYE, CTL or TC button on the waveform monitor is pressed, the output signal is indicated below "WFM". Each time a button is pressed, the display is changed as shown below.

OUT: CMPST→MON [can be selected when the down-converter PCB (AJ-DFC2000) has been installed].

EYE/ENV: CH0→CH1→CH2→CH3

CTL: R/P→CONF1

TC: TC only

D_CONV

This indicates the down-converter output status in the 2 lines below D_CONV. [It appears only when the down-converter PCB (AJ-DFC2000) has been installed.]

The serial output type is indicated on the top line. (The mode selected by F1 on the VIDEO OUT/DOWN_CONV SET UP menu is displayed.)

The analog output signals also change at the same time.

CMPST: 143 Mbps composite serial output.

4:2:2: 270 Mbps component serial output.

4:2:2W: 360 Mbps component serial output.

4:2:0p: 420p progressive component serial output.

The conversion of the aspect ratio from 16×9 to 4×3 is indicated on the bottom line. (The mode selected by F2 on the VIDEO OUT/DOWN_CONV SET UP menu is displayed.)

SQUEEZE: The picture is compressed horizontally, and the whole picture is displayed as a 4×3 active picture.

LETTER: Without changing the aspect ratio, the picture is compressed so that both its vertical and horizontal dimensions are equal, and it is displayed on a 4×3 effective screen.

S.CUT: The left and right edges of the 16×9 picture are cut off, and only the picture in the remaining 4×3 ratio is displayed.

FULL: The picture appears on the screen as is with the aspect ratio remaining unchanged.

□ Setting mode display section

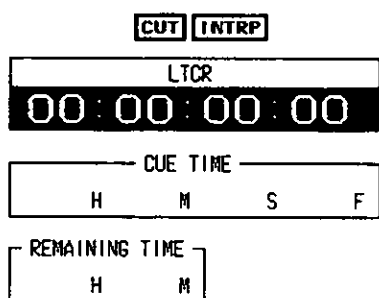

This indicates the mode which has been set.

- CUT:** The audio cut editing mode setting.
XFADE: The audio cross-fade editing mode setting.
VFADE: The audio V fade editing mode setting.
INTRP: Time code interpolation mode (when the time code cannot be read out accurately) setting.
DF: Drop frame mode setting
F1/F2: Field number for VITC.
EMPHASIS: Pre-emphasis applied to audio.
TRACK VAR: This appears when the tracking has been adjusted to a position which is different from its fixed position.
USER FILE NO: User file name display.
TRACK OPT: This appears when the tracking has been adjusted to the optimal position.

□ Remaining tape time

As the tape travels, this indicates the time remaining on the tape.

□ User file display

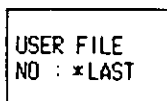

The number of the currently called user file or the file which is called when the power is turned on is indicated. An asterisk (*) appears in front of the file number if the contents of the user file displayed differs from the current settings in one or more places.

□ Time code displays



The time code values are indicated here.

- CTL1:** Regular control signal
CTL2: Control signal (cannot be reset)
LTCR: LTC readout
LUBR: LTC user bit readout
VTOR: VITC readout
VUBR: VITC user bit readout
TCG: Value generated by generator
LUBG: Value generated for LTC user bit
VUBG: Value generated for VITC user bit
E_TC: External time code
E_UB: External user bit

□ Checking the value generated by the generator

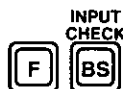

Press the BS key while keeping the F key depressed. The generator value is displayed while the keys are kept depressed.

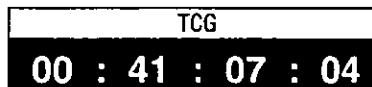

How to display the menus:

•USER SET UP menu:



□ Setting the default value of the time code

- (1) Press the cursor center key.
The display is highlighted.

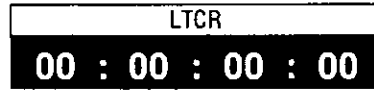
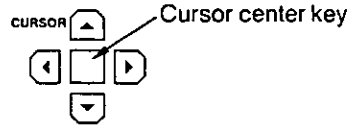

- (2) Press the cursor center key again to change the cursor to a bar cursor, and then input the time code value using the number keys.

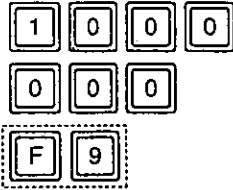

To set a letter (A–F) in the default value of the user bit, press the F key and number key (4–9) together.

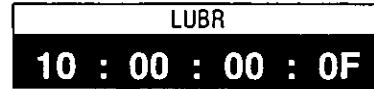

- (3) Press the ENT key.
The cursor is cleared. (This completes the setting of the default value.)

- To clear the setting, press the C key in step (2).
- To check the data which has been input, press the INPUT CHECK (F+BS) key.

□ Setting and checking the cue time

- (1) Press the cursor center key.
The time code display is highlighted.

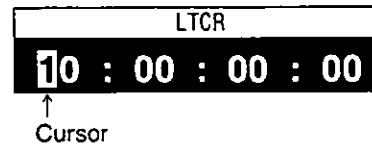
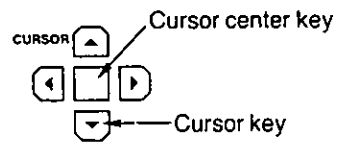

- (2) Press the (▼) cursor key.
The cue time display is highlighted.

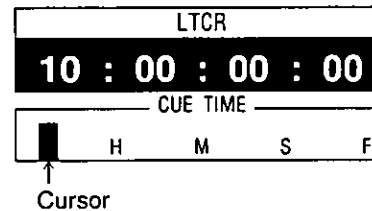

- (3) Press the cursor center key again to change the cursor to a bar cursor, and then input the value using the number keys.

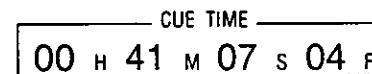
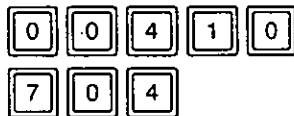

- (4) Press the ENT key.
The cursor is cleared. (This completes the setting of the cue time.)
- (5) Press the SEARCH button. The cue time on the tape is searched and the tape stops.

- If the ENTRY IN button is pressed in step (2), the tape's present position is automatically input.
- If the PREROLL button is pressed in step (5), the tape is prerolled to the cue time.

HOME menu

The menu appears on the screen when **HOME** is pressed.

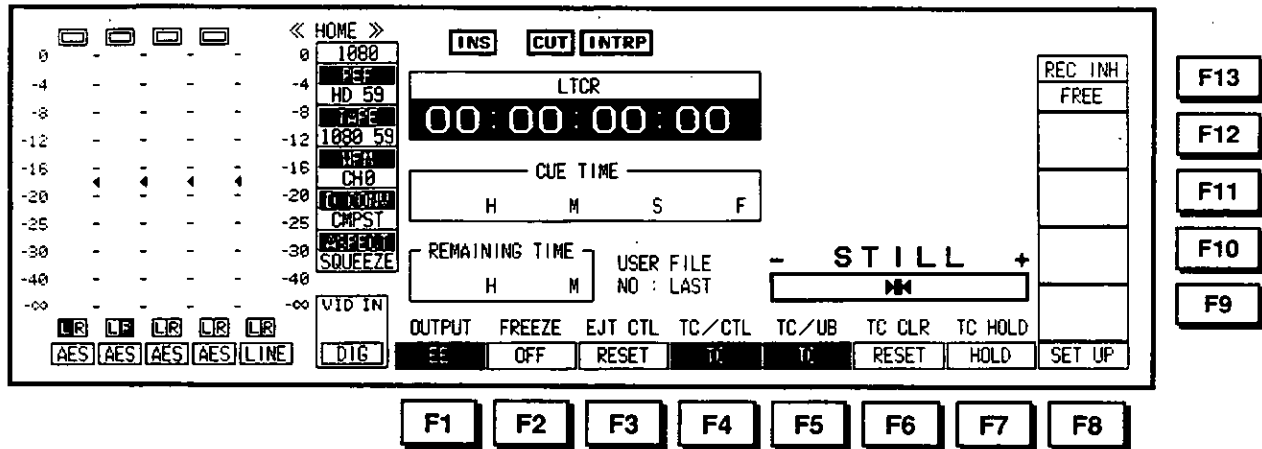

Function keys

| Key | Item | Function |
|-----|---|--|
| F1 | OUTPUT Video/audio output signal selection | The reverse mode is established only while the key is kept depressed. (The selected display appears when the F1 and F keys are pressed together.) TAPE: Outputs playback signals. EE: Outputs EE-system signals. • This key functions only in the STOP, REC or EJECT mode. It does not function during playback. • This key cannot be used to output the cue signal. |
| F2 | FREEZE Flash freeze picture output | This continuously outputs signals for 1 field memory picture. The flash freeze picture is output only while the key is kept depressed. When it is pressed together with the F key, the setting is fixed. |

Function keys

| Key | Item | Function |
|--------|---|---|
| F3 | EJT CTL | <p>RESET: Clears the CTL1 in the EJECT mode. Also, CTL2 is cleared when the cassette is inserted.</p> <p>HOLD: Holds the CTL1/CTL2 in the EJECT mode.</p> |
| F4 | TC/CTL Time code/control signal selection | <p>TC: Displays the time code signal.</p> <p>CTL1: Displays the value of the control signal (time data). (Value can be reset to zero.)</p> <p>CTL2: When the cassette tape is inserted, the time data is automatically reset to zero, and this value cannot subsequently be reset.</p> |
| F5 | TC/UB Time code/user bit display selection | <p>TC: Displays the time code value.</p> <p>UB: Displays the user's bit value.</p> <ul style="list-style-type: none"> • This key is valid only when TC has been selected by the F4 key. • During playback, the value of the time code read out is displayed. • During recording, the time code value to be recorded on the tape is displayed. <p>To display the value generated by the time code generator in any mode other than recording, press the INPUT CHECK (F+BS) button.</p> |
| F6 | CTL CLR CTL value clear (TC CLR) TCG value clear (UB CLR) UBG value clear | <p>This is effective only when TC/CTL is set to "CTL1".</p> <p>RESET: The CTL1 time data is reset to zero.</p> <p>This is effective only when TC/CTL and TC/UB are set to "TC".</p> <p>RESET: When the F6 key is pressed together with the F key, the TCG value is reset to zero.</p> <p>This is effective only when TC/CTL is set to "TC" and TC/UB is set to "UB". However, there are two UBG values, VITC UBG and LTC UBG, and so the correspondences between the TCR settings on the TC/CHR menu and the value or values which are reset are as shown below.</p> <p>When TCR is set to AUTO: Both the LTC UBG and VITC UBG are reset to zero.</p> <p>When TCR is set to LTC: The LTC UBG is reset to zero.</p> <p>When TCR is set to VITC: The VITC UBG is reset to zero.</p> |
| F7 | TC HOLD Time code value hold | <p>This holds the display of the time code value applying at the moment when the key was pressed.</p> <ul style="list-style-type: none"> • When the key is pressed again, the value held is released. |
| F8 | SET UP | This transfers operation to the HOME SET UP menu. |
| F9-F12 | — | |
| F13 | REC INH Recording inhibit mode setting | <p>FREE: Recording is enabled.</p> <p>NRML.REC: Normal recording is inhibited. (The REC INHIBIT lamp flashes.)</p> <p>ALL: All recording is inhibited. (The REC INHIBIT lamp lights.)</p> <ul style="list-style-type: none"> • The CASSETTE REC INHIBIT mode set by the accidental erasure prevention pins of the cassette tape takes precedence over setting of this key. |

HOME SET UP menu

This menu appears when the **HOME** key and then **F8** key are pressed or the **SET UP** key and then the **F1** key are pressed.

0 [] [] [] []

-4 [] [] [] []

-8 [] [] [] []

-12 [] [] [] []

-16 [] [] [] []

-20 [] [] [] []

-25 [] [] [] []

-30 [] [] [] []

-40 [] [] [] []

-∞ [] [] [] []

<< HOME : SET UP >>

1080
RES
HD 59
1080 59
CH0
CF DET
CMPST
SQUEEZE

REFERENCE
OUT REF : **AUTO** INPUT HD REF INTSC REF

CF DET
NTSC REF : **FREE**

LTCR 00:00:00:00

REC INHIBIT
CASSETTE
FREE
VID/CNTL
ALL

STBY OFF
3MIN
STILL
1MIN
PREROLL
5SEC

- STILL +
M

F13

F12

F11

F10

F9

VID IN
DIG

SYNC PLY AT PLAY PRG PLY TAPE MD.

OFF **FIELD** FINE 0.0% HD STOP

EXIT

F1 **F2** **F3** **F4** **F5** **F6** **F7** **F8**

Function keys

| Key | Item | Function |
|--------|---|---|
| F1 | SYNC PLY Sync play setting | This automatically compensates for startup in the playback mode. If, for instance, the VTR tape is played back from the preroll point, the tape will reach the IN point after the preroll time has elapsed. ON: The sync play function operates. OFF: The regular playback mode is established. |
| F2 | AT PLAY Field/frame playback selection in jog or variable mode | FIELD: Playback in field units FRAME1/FRAME2: The tape is played back in frame increments from $-1\times$ to $+1\times$ normal tape speed; at any other speed, it is played back in field increments. Use FRAME1 when using a tape with a break in the scenes resulting from a transition from field 2 to field 1 in cases where, for instance, the image on the tape has been edited with field 1 serving as the break. Use FRAME2 when field 2 serves as the break in the scene. |
| F3 | PRG PLY Programmed play | FINE: Programmed play speed can be varied in 0.1% steps. COARSE: Programmed play speed can be varied in 1.0% steps. |
| F4 | PRG PLY Programmed play function setting | This enables the tape speed of normal playback to be varied within a $\pm 15\%$ range, using the F3 key. Refer to the section on the "Programmed play function". |
| F5 | — | |
| F6 | TAPE MD Tape mode selection in standby OFF mode | HD.STOP: The drum rotation is stopped in the tension release mode ("losing"). HLF LOAD: The tape is set to the half-loaded mode. |
| F7 | — | |
| F8 | EXIT | Operation is returned to the HOME menu. |
| F9–F10 | — | |
| F11 | PREROLL Preroll time selection | After pressing the F11 key, the ADJUST control needs to be turned. Any preroll time from 0 to 30 seconds can be selected. |
| F12 | STILL Still mode hold time setting | This sets the STOP/still (still-picture) mode hold time. The tape tension is automatically released ("losing") when a specific time has elapsed so that the tape will be protected. This key is used to set the time. After pressing the F12 key, the ADJUST control needs to be turned. The time can be set to 1 sec., 3 sec., 30 sec., 1 min., 3 min. or 5 min. |
| F13 | STBY OFF Standby mode hold time setting | This sets the time it takes for operation to be transferred from the the "losing" mode to the standby OFF mode. After pressing the F13 key, the ADJUST control needs to be turned. The time can be set to 1 sec., 3 sec., 30 sec., 1 min., 3 min., 16 min. or infinity (∞). |

Functions

□ Reference

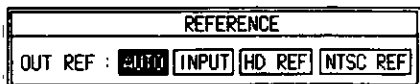

OUT REF: Video output reference

AUTO: When the HD REF input signal has been supplied, that signal serves as the reference signal; when it has not been supplied, the HD serial input signal serves as the reference signal. When neither the HD REF input nor HD serial input signal has been supplied, the internal sync signal serves as the reference signal.

INPUT: HD serial input signal serves as the reference.

HD REF: The signal supplied to the HD REF IN connector serves as the reference.

NTSC REF: The menu appears only when the down-converter PCB (AJ-DFC2000, optional accessory) has been installed. The black burst signal supplied to the NTSC REF connector serves as the reference.

Operation

- (1) Press the cursor center key. The cursor appears.

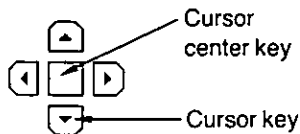

- (2) Use the cursor keys to move the cursor to the item to be set. The selected item now flashes on the display.

OUT REF: REF

- (3) Press the ENT key. The setting is now entered.

□ CF DET (color frame detection) mode

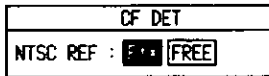

*This menu appears when the down-converter PCB (AJ-DFC2000, optional accessory) has been installed.

NTSC REF: This sets the mode in which the color frames of the reference signal for the video output are to be detected.

FIX: The color frames as referenced to the H sync and burst phases specified by SMPTE 170M are detected.

FREE: The sync and burst phase difference is not detected, and the color frames are artificially determined internally.

Operation

- (1) Press the cursor center key. The cursor appears.

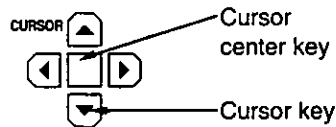

- (2) Press the F key and cursor key together to move the cursor to the CF DET block.

NTSC REF: [FIX] []

- (3) Use the cursor keys to move the cursor to the item to be set. The selected item is highlighted on the display.

NTSC REF: [] [FREE]

- (4) Press the ENT key. The setting is now entered.

□ Programmed play function

- (1) Press the F3 (PRG PLY) key to set the programmed playing steps, and then press the F4 (PRG PLY) key to set the programmed play speed.

PRG PLY
[2.0%]

- (2) Press the PLAY and VAR buttons together.

- (3) To change the playback speed, turn the ADJUST control while keeping the VAR button depressed.

- (4) Press the STOP button to stop programmed play.

VIDEO IN menu

This menu appears when the **VIDEO IN** key is pressed.

The screenshot displays the VIDEO IN menu interface. At the top, it shows the title « VIDEO IN » and the LTCR (00:00:00:00). The main area is divided into several sections:

- Left Column:** A vertical scale from 0 to -40 with tick marks and a list of menu items: 1080, HD 59, 1080 59, CH0, COMPST, and SQUEEZE.
- Right Column:** A vertical scale from 0 to -40 with tick marks.
- Center:** A horizontal bar labeled "STILL" with a play button icon in the middle.
- Bottom Row:** A row of function keys labeled F1 through F8.
- Bottom Right:** A vertical stack of function keys labeled F9, F10, F11, F12, and F13.
- Bottom Left:** A row of buttons for video format settings: LR, LR, LR, LR, LR, AES, AES, AES, AES, LINE, DIG, VIDEO, and INT SG.

Function keys

| Key | Item | Function |
|--------|--|--|
| F1 | VIDEO Video input signal selection | DIGITAL: This selects the HD serial input signal. INT SG: This selects the video signals from the internal signal generator. |
| F2-F3 | — | |
| F4 | INT SG Selection of signal from internal signal generator | 100% CB: The 100% color bar signal is selected. 75%CB: The 75% color bar signal is selected. BLACK: The black burst signal is selected. MULT-BST: The multi burst signal is selected. RAMP: The ramp signal is selected. SIF PLL: The signal for checking the serial interface PLL is selected. SIF EQ: The signal for checking the serial interface equalizer is selected. |
| F5-F13 | — | |

VIDEO OUT menu

This menu appears when the **VIDEO OUT** key is pressed.

<< VIDEO OUT >>
LTCR 00:00:00:00

| | | | | | | | | | |
|---|----|----|-----|-----|-----|-----|-----|-----|----|
| 0 | -4 | -8 | -12 | -16 | -20 | -25 | -30 | -40 | -∞ |
| 0 | -4 | -8 | -12 | -16 | -20 | -25 | -30 | -40 | -∞ |
| 0 | -4 | -8 | -12 | -16 | -20 | -25 | -30 | -40 | -∞ |

1080
HD 59
1080 59
VFR
CH0
T-DOWN
CMPST
EFFECT
SQUEEZE

VID IN
DIG

| | | | |
|-----|-----|-----|------|
| dB | dB | dB | mV |
| 3 | 3 | 3 | 100 |
| 0 | 0 | 0 | 50 |
| -3 | -3 | -3 | 0 |
| -10 | -10 | -10 | -50 |
| -20 | -20 | -20 | -100 |
| -∞ | -∞ | -∞ | -∞ |

SERIAL
SYSPHASE

VIDEO PHASE

SERIAL
VPHASE

SAMPLES

SAMPLES

SERIAL
SYSPHASE

| | | | |
|-------|-------|-------|----------|
| Y | PB | PR | BLACK. L |
| UNITY | UNITY | UNITY | UNITY |

| | | | |
|----------|-------|---------|----|
| DOWNCONV | STATE | INTERP. | ON |
|----------|-------|---------|----|

F13

F12

F11

F10

F9

- F1
F2
F3
F4
F5
F6
F7
F8

Function keys

| Key | Item | Function |
|---------|---|---|
| F1 | Y Y level adjustment | |
| F2 | P _B P _B level adjustment | |
| F3 | P _R P _R level adjustment | The F1 to F4 keys are used to adjust the levels of the video output signals. |
| F4 | BLACK.L Black level adjustment | |
| F5 | V PHASE Video to sync phase adjustment | This adjusts the phase in relation to the sync signal among the output video signals. (The ON/OFF display is switched when the F key and F5 key are pressed together.) |
| F6 | — | |
| F7 | SERIAL SYS PHASE | This adjusts the horizontal phase of the output signal in relation to the reference signal. |
| F8 | — | |
| F9 | INTERP. | ON: This sets the interpolation to ON during slow-motion playback. (The signals are subjected to the filter for the vertical direction in order to reduce the vertical motion of the picture during slow-motion playback.) OFF: Interpolation is not set to ON even during slow-motion playback. (At this setting, the picture may appear to be affected by slight vertical motion during slow-motion playback.) |
| F10–F11 | — | |
| F12 | STATE | This transfers operation to the STATE screen. |
| F13 | DOWN CONV | This transfers operation to the DOWN CONV SET UP screen. (The AJ-DFC2000 down-converter PCB must be installed for this.) |

Video output signal adjustment

- Fine adjustment

When one of the F1 to F3 keys is pressed while the F key is kept depressed, the scale changes so that the item corresponding to the pressed key can be finely adjusted across a -3 dB to $+3$ dB range.

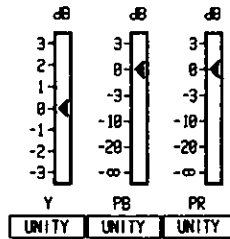

- UNITY/VAR

- When the UNITY/VAR (F+3) key is pressed during adjustment, the VAR value is returned to the UNITY value. When the key is pressed again, the UNITY value is returned to the VAR value (original adjustment value).

(This function works for the adjustments on the VIDEO OUT menu.)

AUDIO OUT SET UP/VIDEO OUT STATE menu

This menu appears when the **VIDEO OUT** key, and then the **F12** key are pressed, or when the **AUDIO OUT** key, the **F8** key and then the **F12** key are pressed.

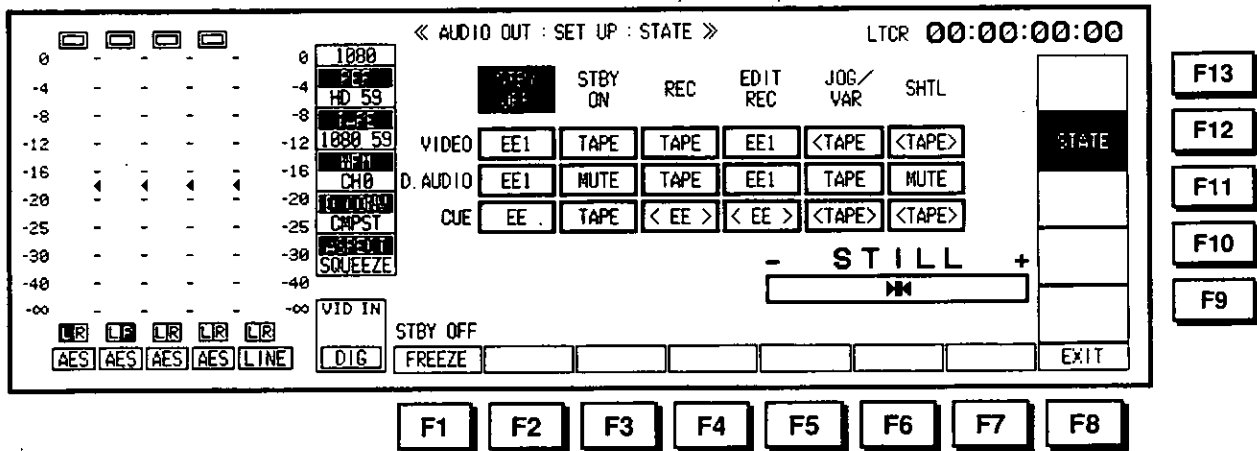

Function keys

| Function key | Item | Function |
|--------------|---|---|
| F1 | STBY OFF Video signal output selection in STBY OFF | This sets the video signal output when the STBY OFF mode is set to TAPE. FREEZE: The video signal output is frozen. MUTE: The video signal output is muted. |
| F2-F7 | — | |
| F8 | EXIT | Operation is returned to the VIDEO OUT menu. |
| F9 | — | |
| F10 | — | |
| F11 | — | |
| F12 | STATE | This transfers operation to the STATE screen. |
| F13 | — | |

Functions

□ Selecting the TAPE/EE output signal

The video, audio and cue signals which are to be output during the VTR's operation can be switched to TAPE or EE signals.

- (1) Press the cursor center key to display the cursor.

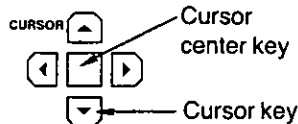

- (2) Use the cursor keys to move the cursor to the desired position.

- The cursor will not move to sections which cannot be set.

| | STBY OFF | STBY ON | REC | EDIT REC | JOG/ VAR | SHTL |
|----------|----------|---------|--------|----------|----------|--------|
| VIDEO | EE1 | TAPE | TAPE | EE1 | <TAPE> | <TAPE> |
| D. AUDIO | EE1 | MUTE | TAPE | EE1 | TAPE | MUTE |
| CUE | EE | TAPE | < EE > | < EE > | <TAPE> | <TAPE> |

- (3) Press the cursor center key to select TAPE or EE.
Refer to the table below for the types of choices available.

| Mode CH | STBY OFF | STBY ON | REC | EDIT REC | JOG/VAR | SHTL |
|------------|--------------------|--------------------|--------------------|-------------|--------------|--------------|
| VIDEO | TAPE EE1 EE2 | TAPE EE1 EE2 | TAPE EE1 EE2 | TAPE EE1 | TAPE | TAPE |
| D.AUDIO | MUTE EE1 EE2 | MUTE EE1 EE2 | TAPE EE1 EE2 | TAPE EE1 | TAPE MUTE | TAPE MUTE |
| CUE | TAPE EE | TAPE EE | EE | EE | TAPE | TAPE |

- If the settings are unilaterally determined during head selection on the TEST menu or during editing, the settings made during such an operation take precedence over the settings in the above table.
- When TAPE/EE has been set by the F1 (OUTPUT) key on the HOME menu, the HOME menu setting takes precedence.

How to display the menus:

- HOME menu:

HOME

VIDEO OUT/DOWN CONV SET UP menu

This menu appears when the **F13** key is pressed from **VIDEO OUT** or the **F5** key is pressed from **SET UP** (when the AJ-DFC2000 down-converter PCB has been installed).

VIDEO OUT : DOWN CONV SET UP

LTCR 00:00:00:00

< SDI > < ANALOG COMPOSITE > < D CONV CNTRL >

SYS PHASE SYS H H. POSIT

0 SAMPLES 0 SC 0 SAMPLES

SYS SC 0 DEGREE

MARKER OFF

H. POSIT UNITY

7.5%STUP OFF

H. ENHANC OFF

V. ENHANC OFF

VID IN SDI ANALOG COMPOSITE

TYPE ASPECT SYS PHASE S AUDIO SYNC SYS H SYS SC

COMPST SQUEEZE UNITY OR OR UNITY UNITY EXIT

F1 F2 F3 F4 F5 F6 F7 F8

F9 F10 F11 F12 F13

Function keys

| Key | Item | Function |
|-----|---|--|
| F1 | TYPE down-converter serial output selection | This selects the type of serial signal which is output from the down-converter. It is selected by pressing the F and F1 keys together. COMPST: The composite SDI is output. 4:2:2: The 270 Mbps component SDI is output. 4:2:2W: The 360 Mbps component SDI is output. 4:2:0p: The 420p progressive component SDI is output. |
| F2 | ASPECT Selection of aspect ratio conversion from 16×9 to 4×3 | One of the following settings can be selected in combination with the F1 key. This function can also be selected by pressing the F and F2 keys together. SQUEEZE: The picture is compressed horizontally, and the whole picture is displayed as a 4×3 active picture. LETTER: The picture is compressed horizontally and vertically at an equal rate without changing its aspect ratio, and it is displayed as a 4×3 active picture. Parts without the picture appear at the top and bottom of the screen. SIDE CUT: The left and right edges of the 16×9 picture are cut off, and only the picture in the remaining 4×3 ratio is displayed. FULL: The picture appears on the screen as is with the aspect ratio remaining unchanged. |

| | | | | | | | | |
|------------|---------|--------|----------|---------|--------|----------|--------|--------|
| F1: TYPE | COMPST | | | 4:2:2 | | | 4:2:2W | 4:2:0p |
| F2: ASPECT | SQUEEZE | LETTER | SIDE CUT | SQUEEZE | LETTER | SIDE CUT | FULL | FULL |

Function keys

| Key | Item | Function |
|-----|-----------|---|
| F3 | SYS PHASE | This adjusts the sync phase of the down-converter's serial output in relation to the reference signal. The phase can be adjusted by pressing the F and F3 keys together and then turning the ADJUST control. |
| F4 | S AUDIO | ON: The audio CH1, 2, 3 and 4 signals are output to the down-converter's serial output connectors. OFF: No audio signals are output to the down-converter's serial output connectors. |
| F5 | SYNC | ON: The sync signal is superimposed onto the analog signals which are output from the down-converter's VIDEO 1 output connector. OFF: The sync signal is not superimposed onto the analog signals which are output from the down-converter's VIDEO 1 output connector. |
| F6 | SYS H | This adjusts the sync phase of the down-converter's video output in relation to the reference signal. The phase can be adjusted by pressing the F and F6 keys together and then turning the ADJUST control. |
| F7 | SYS SC | This adjusts the SC phase of the down-converter's video output in relation to the NTSC reference signal. The phase can be adjusted by pressing the F and F7 keys together and then turning the ADJUST control. |
| F8 | EXIT | This returns operation to the VIDEO OUT menu or SET UP menu on the main menu. |
| F9 | V.ENHANCE | ON: This enhances the vertical detail of the down-converter's output picture. OFF: This does not enhance the vertical detail of the down-converter's output picture. |
| F10 | H.ENHANCE | ON: This enhances the horizontal detail of the down-converter's output picture. OFF: This does not enhance the horizontal detail of the down-converter's output picture. |
| F11 | 7.5% STUP | ON: This adds 7.5% setup to the down-converter's composite serial output and video output. OFF: This does not add 7.5% setup to the down-converter's composite serial output and video output. |
| F12 | H. POSIT | This adjusts the 4×3 picture cutoff position when SIDE CUT has been set using F2 (ASPECT). The position can be adjusted by pressing the F and F12 keys together and then turning the ADJUST control. |
| F13 | MARKER | "Marker" denotes the function which uses markers to display the 4×3 picture cutoff position on the HD serial monitor when SIDE CUT has been set using F2 (ASPECT). ON: The marker is displayed on the HD serial monitor. OFF: The marker is not displayed on the HD serial monitor. |

AUDIO IN menu

This menu appears when the **AUDIO IN** key is pressed.

This indicates the statuses of the audio input signals.

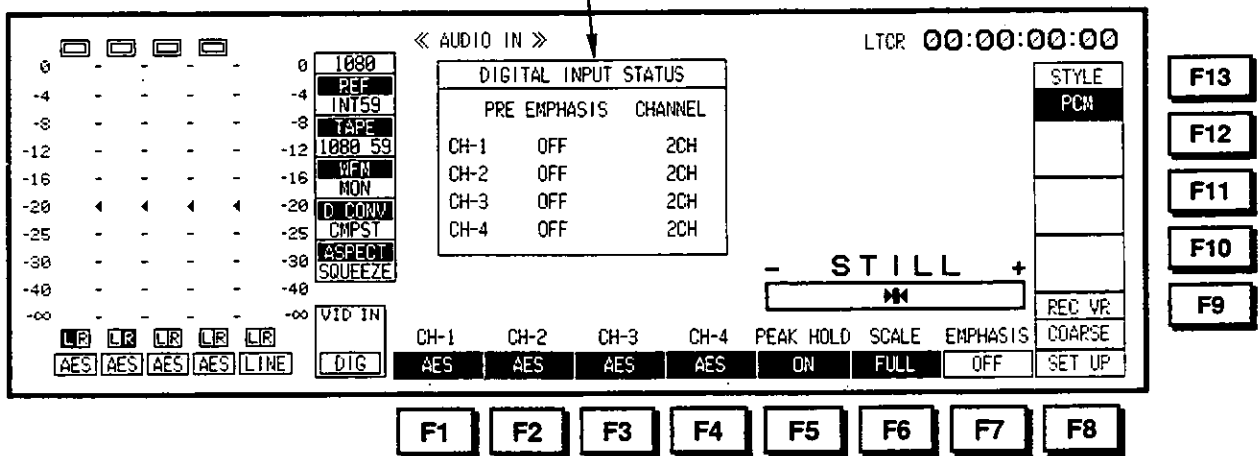

Function keys

| Key | Item | Function |
|-----|--------------------------------------|---|
| F1 | CH-1 CH-1 input channel selection | ANALOG: The analog audio input signal is selected. AES: The AES input signal is selected. SERIAL: The serial digital input signal is selected. INT SG: The internal signal generator signal is selected. |
| F2 | CH-2 CH-2 input channel selection | |
| F3 | CH-3 CH-3 input channel selection | |
| F4 | CH-4 CH-4 input channel selection | |

Function keys

| Key | Item | Function |
|---------|--|--|
| F5 | PEAK HOLD Peak hold setting | This function holds the peak values of the recording and playback levels. ON: The peak values are held. OFF: The peak values are not held. |
| F6 | SCALE Level meter scale switching | This switches the on-screen level meter scale between the standard scale and fine adjustment scale. FINE: The scale indicates the audio input signal levels in increments of 0.5 dB (ranging from -22 dB to -14 dB). FULL: Standard scale (ranging from -∞ to 0 dB). |
| F7 | EMPHASIS Pre-emphasis setting | When analog audio input signals are to be recorded on digital audio channels, the emphasis circuit is activated to boost the level of the high-frequency components and then the de-emphasis circuit is activated to attenuate only those components during playback. This function is set to ON when the F7 key is pressed together with the F key. ON: The emphasis and de-emphasis circuits are activated. OFF: Normal recording mode. |
| F8 | SET UP | This transfers operation to the AUDIO IN SET UP menu. |
| F9 | REC VR Recording level adjustment control | FINE: This sets the recording level adjustment controls to the fine adjustment mode in which the levels can be adjusted in -3 dB to +3 dB range relative to the setting at the COARSE position. COARSE: The recording level adjustment controls function in the full range mode. |
| F10-F12 | — | |
| F13 | STYLE | DATA is selected when AC-3 or other coded audio signals are to be input to or output from the digital audio input or output (AES channel 1/2 & 3/4 connectors). The selection can be changed by pressing the F13 key together with the F key. PCM: This is selected when regular AES signals are to be input or output. DATA: This is selected when coded audio signals are to be input to or output from the AES channel 1/2 & 3/4 input or output connectors. |

Function

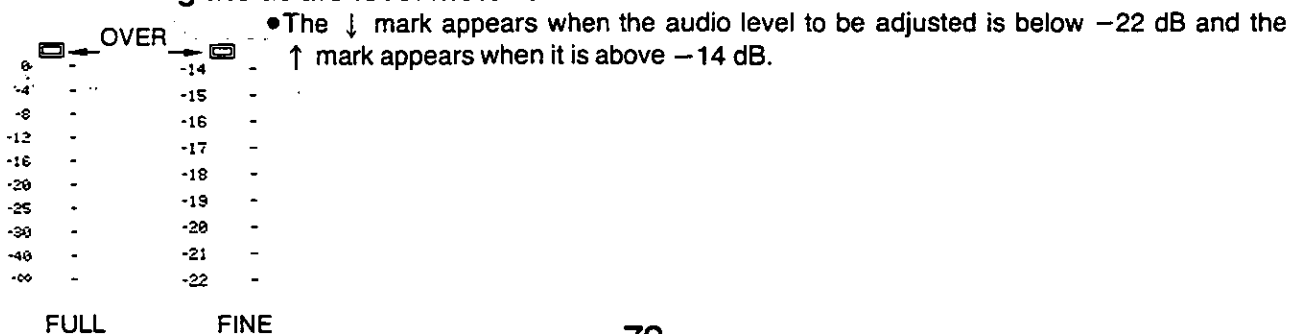
 Switching the audio level meter scale

AUDIO IN SET UP menu

This menu appears when the **AUDIO IN** key and then the **F8** key are pressed or when the **SET UP** and then the **F6** keys are pressed.

The screenshot displays the 'AUDIO IN : SET UP' menu. At the top, it shows the title '<< AUDIO IN : SET UP >>' and the LTCR time '00:00:00:00'. The main area is divided into several sections:

- Level Meters:** On the left, there are five vertical level meters for channels LR, LF, LB, RB, and RB, with values ranging from 0 to -40 dB.
- Parameter List:** On the right, a list of parameters is shown with their current values: 1000, FEF, HD 59, 1000, 59, 1000, 59, CH0, 1000, 59, CMPST, 1000, 59, SQUEEZE.
- Input Selection:** Below the parameter list, there are buttons for 'LR', 'LF', 'LB', 'RB', 'RB', 'AES', 'AES', 'AES', 'AES', 'LINE', and 'DIG'.
- CH-MIX:** A section with 'ON' and 'OFF' buttons.
- Navigation:** 'CUE', 'LINE', and 'EXIT' buttons.

Surrounding the menu are several function keys: F1 through F8 are arranged in a horizontal row below the menu; F9, F10, F11, F12, and F13 are arranged in a vertical column to the right of the menu.

Function keys

| Key | Item | Function |
|-------|--|---|
| F1–F5 | — | |
| F6 | CH-MIX Mixing of input signals and simultaneous playback signals for recording | This selects the signals of any two channels, from among the signals which are input to the digital audio channels and the tape playback signals, to be mixed for recording in the desired ratio. Refer to the section on mixing recording. |
| F7 | CH-MIX Mixing of input signals and simultaneous playback signals for recording prohibited | ON: This function is set ON when the F6 key is pressed, and mixing is enabled. OFF: This function is set OFF when the F7 key is pressed, and channel mixing is disabled. •Even when the function is set OFF, the mixing settings established by the F6 key are stored. |
| F8 | EXIT | Operation is returned to the AUDIO IN menu. |
| F9 | CUE Selection of input signal to be recorded on analog cue channel | D-MIX: This mixes and records the signals which are supplied to the digital audio channels selected by the F10–F13 keys. LINE: This records the signal which is supplied to the CUE IN connector. AUTO: During normal recording, this mixes and records all the CH1 to CH4 input signals. During editing, the input signals are mixed and recorded in the channels selected by "Edit channel selection" and the playback signals are mixed and recorded in the channels which have not been selected. Cue can be used as the digital channel back-up at all times. |
| F10 | CUE MIX CH-1 Mixing for cue channel | These select the channels when sound to be recorded in the digital audio channels is to be simultaneously mixed and recorded in the cue channel as well. |
| F11 | CUE MIX CH-2 Mixing for cue channel | The function is displayed when D-MIX has been selected by the F9 key. |
| F12 | CUE MIX CH-3 Mixing for cue channel | SOURCE: The input signals are mixed and recorded in the cue channel. |
| F13 | CUE MIX CH-4 Mixing for cue channel | TAPE: The playback signals are mixed and recorded in the cue channel. OFF: Signals are not mixed and recorded in the cue channel. |

Functions

□ Mixing recording

- (1) Press the F6 (CH-MIX) key to set it to ON.
The mixing graph now appears on the screen.

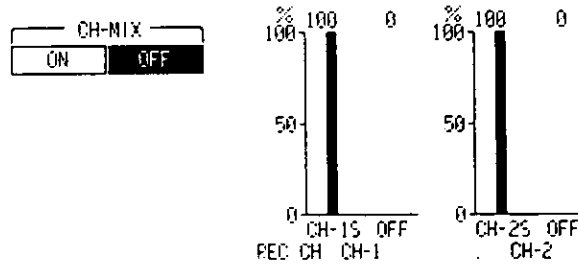

- (2) Press the cursor center key to display the cursor.

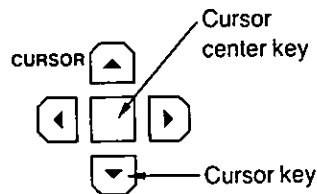

- (3) Use the cursor keys to move the cursor to the channel whose signal is to be mixed.

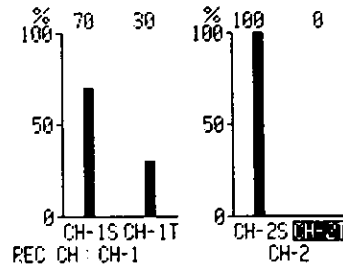

- (4) Press the cursor center key to select the signal to be mixed.

The desired signal can be set for each channel.
The signals which can be selected are as follows:

| | | | | |
|-------|-------|-------|-------|--|
| CH-1S | CH-2S | CH-3S | CH-4S | (input signal of channel concerned) |
| CH-1T | CH-2T | CH-3T | CH-4T | (playback signal of channel concerned) |
| OFF | | | | (no mixing) |

- The same signal cannot be selected for one channel.

□ **Mixing recording (continued)**

(5) Move the cursor to the mixing ratio display section, and turn the ADJUST control to set the mixing ratio (in 1% increments).

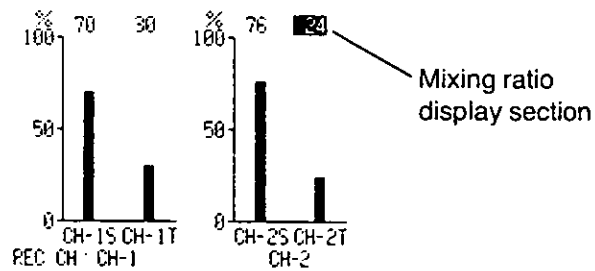

Notes:

- When the PLAY button is pressed after proceeding with the CH-MIX mode setting, the F6 (CH-MIX) key flashes. Normal playback sound is output at this time.
- When the F6 key is pressed while it is flashing, the CH-MIX sound is output. If any adjustments are to be made while listening to the actual mixed sound, this is the time to proceed.
- Press the F7 (CH-MIX) key to set the CH-MIX mode function to OFF.

Output sound produced by VTR mode and F6/F7 key statuses

| VTR mode | Key status | F6 key lights | F6 key flashes | F7 key OFF |
|---------------------|------------|----------------|----------------|----------------|
| EE/STOP | | CH-MIX sound | — | EE/TAPE |
| PLAY (EDIT, NORMAL) | | CH-MIX sound | Playback sound | Playback sound |
| REC | | CH-MIX sound | — | Playback sound |
| JOG/VAR/SHTL | | Playback sound | — | Playback sound |

AUDIO OUT menu

This menu appears when the **AUDIO OUT** key is pressed.

This indicates the statuses of the audio output signals.

0 0 1000
-4 -4 HD 59
-8 -8 TEPE
-12 -12 1000 59
-16 -16 WPH
-20 -20 CH0
-25 -25 D DUBW
-30 -30 CNPST
-40 -40 RESPEL
-48 -48 SQUEEZE
-∞ -∞

VID IN
RES RES RES RES LINE
DIG

<< AUDIO OUT >>

DIGITAL OUTPUT STATUS

| PRE EMPHASIS | CHANNEL |
|--------------|---------|
| CH-1 OFF | 2CH |
| CH-2 OFF | 2CH |
| CH-3 OFF | 2CH |
| CH-4 OFF | 2CH |

MASTER VR

CH-4 ON
CH-3 ON
CH-2 ON
CH-1 ON
PB VR
COARSE

JOG/VAR PROCESS AUDIO

| CH-1 | CH-2 | CH-3 | CH-4 | PEAK HOLD | SCALE | MONI AUTO | SET UP |
|------|------|------|------|-----------|-------|-----------|--------|
| ON | ON | ON | ON | ON | FULL | SHTL | SET UP |

LTCR 00:00:00:00

F13
F12
F11
F10
F9

F1 F2 F3 F4 F5 F6 F7 F8

Function keys

| Key | Item | Function |
|-----|--|--|
| F1 | JOG/VAR PROCESS AUDIO CH1 | |
| F2 | JOG/VAR PROCESS AUDIO CH2 | These establish whether the audio signals are to be digitally processed in the JOG/VAR mode. |
| F3 | JOG/VAR PROCESS AUDIO CH3 | ON: The signals are digitally processed in the JOG/VAR mode. OFF: The signals are not digitally processed in the JOG/VAR mode. |
| F4 | JOG/VAR PROCESS AUDIO CH4 | |
| F5 | PEAK HOLD Peak hold setting | This function holds the peak values of the recording and playback levels. ON: The peak values are held. OFF: The peak values are not held. |
| F6 | SCALE Level meter scale switching | This switches the on-screen audio level meter scale between the standard scale and fine adjustment scale. FINE: The scale indicates the audio output signal levels in increments of 0.5 dB (ranging from -22 dB to -14 dB). FULL: Standard scale (ranging from -∞ to 0 dB). Refer to "Switching the audio level meter scale" on the AUDIO IN menu on page 72. |
| F7 | MONI AUTO Switching of signals output from monitor connector | SHTL: In the SHTL, FF or REW mode, the analog cue channel signal is output; in any other mode, the L/R audio signals selected by the AUDIO MONITOR L/R buttons are output. OFF: The L/R audio signals selected by the AUDIO MONITOR L/R buttons are output at all times. VAR SHL: In the VAR, JOG, SHTL, FF or REW mode, the analog cue channel signals are output; in any other mode, the L/R audio signals selected by the AUDIO MONITOR L/R button are output. |
| F8 | SET UP | This transfers operation to the AUDIO OUT SET UP menu. |
| F9 | PB VR Playback level adjustment control | FINE: This sets the audio playback level adjustment controls to the fine adjustment mode in which the levels can be adjusted in the -3 dB to +3 dB range relative to the setting at the COARSE position. COARSE: The audio playback level adjustment controls function in the full range mode. |
| F10 | MASTER VR CH1 | |
| F11 | MASTER VR CH2 | These select the channels for which the master VR will be effective. |
| F12 | MASTER VR CH3 | ON: The master VR is effective for the channel. OFF: The master VR is not effective for the channel. |
| F13 | MASTER VR CH4 | (However, this is valid only when the F9 (PB VR) key has been set to COARSE.) |

*When the F9 key is set to the FINE position, the master VRs no longer function for any of the channels.

AUDIO OUT SET UP menu

This menu appears when the **AUDIO OUT** key and then the **F8** keys are pressed or when the **SET UP** key and then the **F7** key are pressed.

<< AUDIO OUT : SET UP >>
LTDR 00:00:00:00

| | | | | | |
|-----|-----|---------|---|---------|-------|
| 0 | 0 | 1000 | | | |
| -4 | -4 | REF | | | |
| -8 | -8 | HD 59 | | | |
| -12 | -12 | TAP | | | |
| -16 | -16 | 1000 59 | | | STATE |
| -20 | -20 | WFH | | | |
| -25 | -25 | CH0 | | | |
| -30 | -30 | COMPST | | | |
| -40 | -40 | SQUEEZE | 0 | SAMPLES | |
| -∞ | -∞ | VID IN | | | |

LR LR LR LR LR
A/VPHASE
STOP FD
PB FADE
PB OUT
A.MONI

AES AES AES AES LINE
DIG
UNITY
ON
ON
INSTANT
VAR
EXIT

-
STILL
+

F1
F2
F3
F4
F5
F6
F7
F8

F13
F12
F11
F10
F9

Function keys

| Key | Item | Function |
|--------|--|--|
| F1 | A/V PHASE Audio and video delay (phase) adjustment | When digital signals which are output from this unit are processed by an externally connected component, a phase difference may arise between the video and audio signals. In such cases, this discrepancy can be eliminated by adjusting the delay in the digital audio signals. ●Refer to the section on the adjustment of the audio output to video. |
| F2 | — | |
| F3 | STOP FD | This function provides instant fading for the muting when the mode is changed for the digital audio output. ON: Fading is provided for the muting during mode change. OFF: Fading is not provided for the muting during mode change. |
| F4 | PB FADE Playback fade ON/OFF | This function removes the audio noise generated at the joins between edited cuts by providing instantaneously V fading during playback. ON: The playback V fading function operates at all the joins between edited cuts on the tape. OFF: The playback V fading function does not operate. |
| F5 | PB OUT Output audio characteristics at playback start | When the operation has been transferred from the stop to play mode, it takes some moments until the audio signals are output. This time can be reduced. INSTANT: The time it takes until the sound is output is reduced. However, the initial part of the sound output will be incomplete. This setting is not recommended for broadcasting applications. It comes in handy during search operations, etc. as a quicker means of monitoring sound. DELAYED: The sound is output once it is complete. |
| F6 | A.MONI Monitor volume control | UNITY: The audio monitor output level is fixed to UNITY value. VAR: The audio monitor output level can be controlled using the headphone volume. |
| F7 | — | |
| F8 | EXIT | Operation is returned to the AUDIO OUT menu. |
| F9–F11 | — | |
| F12 | STATE | This transfers operation to the STATE screen. (See page 67.) |
| F13 | — | |

Functions

□ Adjust of audio output to video

- (1) Press the F1 (A/V PHASE) key to highlight the display.

A/V PHASE
 UNITY

- (2) Adjust the phase difference using the ADJUST control.
 (It can be changed from +16 to -96 in sample increments.)

ADJUST

 +4 SAMPLES
 A/V PHASE
 VAR

- (3) After the adjustment, press the F1 (A/V PHASE) key.

- The UNITY value is returned when the UNITY/VAR (F+3) key is pressed during adjustment. When the UNITY/VAR key is pressed again, the VAR value is returned.

UNITY/VAR
 

□ Fade function

During editing, the cut edit data is automatically recorded, and during playback this data is detected and V fading is applied to this section.

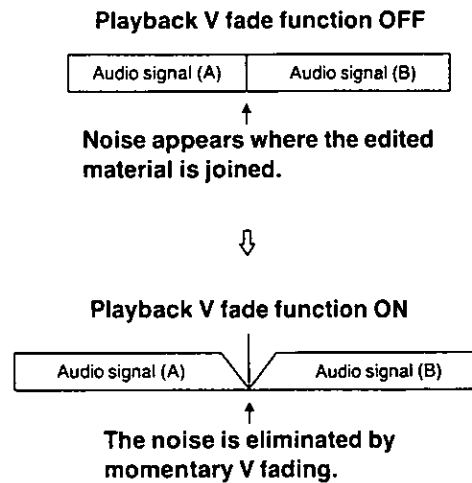

TC/CHR menu

This menu appears when the **TC/CHR** key is pressed.

0 0 0 0

0 1035

-4 PEF

-8 INT60

-12 T-PE

-16 1035 60

-20 RFM

-25 MON

-30 T-CDWA

-40 CHPST

-40 ABSECT

-60 SQUEEZE

LR LF LR LR LR

INT INT INT INT LINE

<< TC/CHR >> SUPER POSITION

SOURCE TC SLAVE UB SLAVE RUN MD DF MD

INT AUTO ON REC PUN ON

LTCR 00:00:00:00

CHR TYPE

REVERSE

SUPER ER

ON

SUPER

TC ST

TCR

AUTO

VID IN

INT

F1 F2 F3 F4 F5 F6 F7 F8

F13

F12

F11

F10

F9

Function keys

| Key | Item | Function |
|-------|--|---|
| F1 | SOURCE Internal/external time code signal selection | <p>INT: The time code of the internal TCG is used.</p> <p>EXT LTC: The LTC time code from the TIME CODE IN connector is used.</p> <p>S LTC: The LTC time code which has been added to the serial signals is used.</p> <p>S VITC: The VITC time code which has been added to the serial signals is used.</p> |
| F2 | TC SLAVE Time code slave lock mode setting | <ul style="list-style-type: none"> •The AUTO or PRESET display appears when the F1 (SOURCE) key has been set to INT. AUTO: The generator is locked to the value read by the reader. In this case, the time code cannot be set. (At the time of editing only) PRESET: The generator is not locked to the value read by the reader. Any setting can be selected for the generator. •When the F1 key is set to "EXT LTC", the SLAVE and DIRECT display appear. SLAVE: The generator is locked to the external LTC time code. If there is no external input, the E-TC time data flashes. DIRECT: The external LTC code is recorded in its original form. If there is no external input, the E-TC: *:*:*:*:*:* display appears. •No display appears for this key when the F1 key has been set to "S VITC" or "S LTC". In this case, the generator value is locked to the external VITC or LTC time code at all times. |
| F3 | UB SLAVE User bit locking | <p>ON: The user bit is locked to the user bit value read by the reader (TCR) or the external user bit value, and it cannot be set.</p> <p>OFF: The user bit is not locked to the user bit value read by the reader. It can be set as desired.</p> |
| F4 | RUN MD Time code running | <p>REC RUN: The time code runs during recording only.</p> <p>FREE RUN: The time code runs all the time like a clock.</p> |
| F5 | DF MD Drop/non-drop frame mode selection | <p>The menu selections can be made only when "INT" is selected by the F1 (SOURCE) key.</p> <p>ON: The drop frame mode is established.</p> <p>OFF: The non-drop frame mode is established.</p> <ul style="list-style-type: none"> •When "EXT LTC", "S VITC" or "S LTC" has been selected by the F1 (SOURCE) key, the setting complies with the drop/non-drop frame mode of the external time code. |
| F6–F9 | — | |
| F10 | TCR Time code readout mode selection | <p>LTC: LTC is read at all times.</p> <p>AUTO: At low speeds, VITC reading takes precedence; if the VITC cannot be read, LTC is read instead.</p> <p>VITC: VITC is read at all times.</p> <ul style="list-style-type: none"> •At any of these settings, the value which has been compensated by the control signal is read if the time code cannot be read out. (The interpolation mode is established, and INTRP appears on the display.) |

| Key | Item | Function |
|-----|---|--|
| F11 | SUPER Superimpose setting | This superimposes the time code and VTR operation mode on the screen. TC: Only the time code is superimposed. TC. ST.: The time code and VTR operation mode are superimposed. OFF: Neither the time code nor VTR operation mode is superimposed. |
| F12 | SUPER ER Error message superimpose ON/OFF | ON: The error messages are superimposed on the screen. OFF: Error messages are not superimposed on the screen. |
| F13 | CHAR TYPE Superimposed character type selection | REVERSE: Characters appear on a black background. NORMAL: Black characters appear with no background. INTENSE: Intensified characters appear. |

Functions

□ Changing the superimposing position

(1) Move the position using the cursor keys.

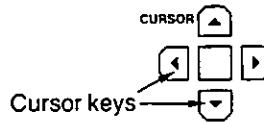
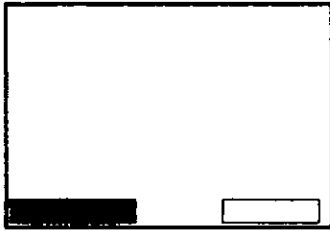

- When a cursor key is kept depressed, the cursor will move quickly.
- The default position is restored by pressing the cursor center key.

□ Time code displays and VTR operation modes

Press the F11 (SUPER) key to set it to TC or TC/ST. The time code and VTR operation mode are displayed as desired.

Time code displays

CTL1: Control signal 1

CTL2: Control signal 2

LTCR: LTC time code readout value

LUBR: LTC user bit readout value

VTCR: VITC time code readout value

VUBR: VITC user bit readout value

TCG: Value generated by time code generator

LUBG: Value generated for LTC user bit

VUBG: Value generated for VITC user bit

EX-TC: External time code value

EX-UB: External user bit value

- The colon (:) between the seconds and frames indicates the readout status of the time code reader.

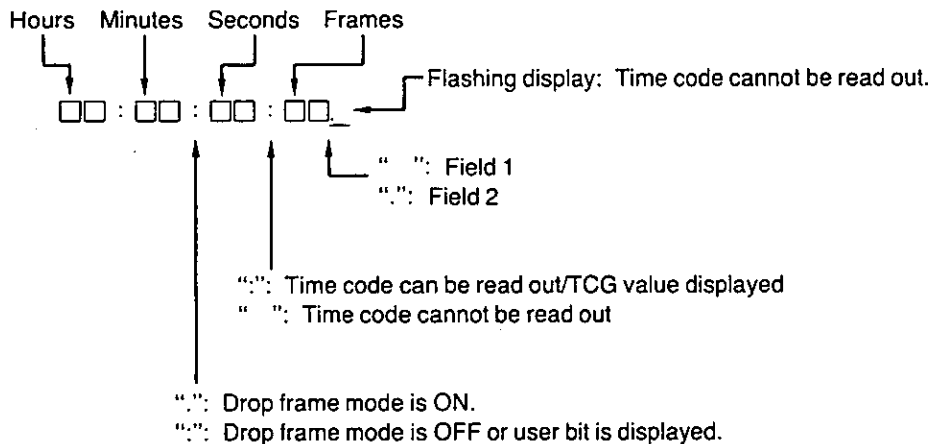

Note:

When "60" has been set for FLD RATE, the NDF mode is forcibly established and the DF mode is not displayed.

□ Time code displays and VTR operation modes (continued)

VTR operation mode

| | | |
|--------------------------|-------------|--|
| EJECT | STANDBY OFF | |
| STOP | EDIT PLAY | (edited playback) |
| PLAY | EDIT REC | (edited recording) |
| REC | PREROLL | |
| F.FWD | CUE UP | |
| REW | PREVIEW | |
| SHTL | AUTO EDIT | (auto editing) |
| VAR | REVIEW | |
| JOG | DMC SAMPLE | (variable memory speed sampling in progress) |
| P.PLAY (programmed play) | DMC PLAY | (variable memory playback in progress) |
| TSO | | |

- In the shuttle/variable, CUE UP and PREROLL modes, the direction of the tape travel is indicated by "+" or "-" and the tape speed by an integer.
- In the jog mode, the forward direction of the tape travel is indicated by "<", tape stop by "*" and the reverse direction by ">".
- In the programmed playback and TSO modes, the direction of deviation is indicated by "+" or "-" and the deviation data by a percentage.

□ Error information displays

Press the F12 (SUPER ER) key to set it to ON.
The error information now appears on the screen.

| | |
|--------------|--|
| V/A ERROR | (error has occurred in video/audio system) |
| SYSCON ERROR | (error has occurred in system control system) |
| REMOTE ERROR | (error has occurred in communication (RS-422A/RS-232C)) |
| TC ERROR | (error has occurred in time code) |
| MECHA ERROR | (trouble has occurred in mechanical system) |
| SERVO ERROR | (trouble has occurred in reel, drum or capstan) |
| SYSTEM ERROR | (other error) |
| CONCEAL V | (error correction for video only) |
| CONCEAL A | (error correction for audio only) |
| CONCEAL V/A | (error correction for video and audio) |
| HIGH ERROR | (high number of inner errors have occurred) |
| LOW RF | (RF level has dropped during recording) |
| TAPE 59→60 | (displayed when a tape recorded at 59.94 Hz is being played back at 60 Hz) |
| TAPE 60→59 | (displayed when a tape recorded at 60 Hz is being played back at 59.94 Hz) |

| F1 (SOURCE) | F2 (TC SLAVE) | F3 (UB SLAVE) | F10 (TCR) | LUBG mode | VUBG mode |
|---------------------|---------------|---------------|-----------|-----------|-----------|
| INT, internal TC | --- | ON | LTC | REGEN | INT UB |
| | | | AUTO | | REGEN |
| | | | VITC | INT UB | |
| | | OFF | LTC | PRESET | INT UB |
| | | | AUTO | | PRESET |
| | | | VITC | INT UB | |
| S LTC S VITC | SLAVE | ON | LTC | EXT REGEN | INT UB |
| | | | AUTO | | EXT REGEN |
| | | | VITC | INT UB | |
| | | OFF | LTC | PRESET | INT UB |
| | | | AUTO | | PRESET |
| | | | VITC | INT UB | |
| EXT LTC | DIRECT | ON | LTC | DIRECT | INT UB |
| | | | AUTO | | EXT REGEN |
| | | | VITC | | |
| | | OFF | LTC | | INT UB |
| | | | AUTO | | |
| | | | VITC | | |
| | | | | | PRESET* |

*The user bit can be set in any mode except recording.

- DIRECT:** Direct recording and output of the external LTC input signal; it is not synchronized with the internal reference signal.
- REGEN:** Slave locking to readout value on tape; UB cannot be set.
- EXT REGEN:** Slave locking to externally input VITC, LTC; UB cannot be set.
- PRESET:** No locking to readout value on tape or external input; UB can be set.
- INT UB:** Mode in which previous UB value is held and REGEN and PRESET are both prohibited; to reset, use the F1 (SOURCE), F2 (TC SLAVE) or F3 (UB SLAVE) key to select one of the above 3 modes.

MULTI CUE (USER) menu

This menu appears when the **[F]** and **[MULTI CUE]** keys are pressed together.

A multiple number of cues—up to 10 time code points—can be set for search and preroll operations.

The screenshot displays the MULTI CUE (USER) menu interface. At the top, it shows the title « MULTI CUE : USER » and the LTRC time code 00:00:00:00. The main area is divided into several sections:

- Left Panel:** A vertical list of time code points from 0 to -40 in increments of 4. Below this are five buttons labeled LR, LF, LR, LR, LR, and a row of five buttons labeled AES, AES, AES, AES, LINE.
- Center Panel:** A vertical list of cue names: 1000, PEF, HD 59, 1000, 1000 59, WFM, CH0, 1000, CMPST, 1000, SQUEEZE. To the right of these are six cue number inputs (1-6) and a central area with a 'STILL' button and a 'M' button.
- Right Panel:** A vertical list of cue numbers from 10 down to 6.
- Bottom Panel:** A row of buttons labeled F1 through F8, and a 'SETTING ALL CLR' button.

Function keys

| Key | Item | Function |
|-----|------------------------------|---|
| F1 | Cue no. 1 assignment | |
| F2 | Cue no. 2 assignment | |
| F3 | Cue no. 3 assignment | |
| F4 | Cue no. 4 assignment | |
| F5 | Cue no. 5 assignment | |
| F6 | SETTING (cue point setting) | ON: Cue points can be set, registered, changed or cleared using the 10 number keys, IN/OUT buttons and scratchpad register. OFF: Cue points cannot be set, changed or cleared. |
| F7 | ALL CLR (all cue data clear) | This clears all the cue data. It can be executed when ON has been selected for SETTING and F7 is pressed together with the F key. |
| F8 | --- | |
| F9 | Cue no. 6 assignment | |
| F10 | Cue no. 7 assignment | |
| F11 | Cue no. 8 assignment | |
| F12 | Cue no. 9 assignment | |
| F13 | Cue no. 10 assignment | |

Displays

Tape indicator

This indicates the present position of the tape with respect to the total length of the tape.

BOT EOT

BOT: Beginning of tape

EOT: End of tape

Cue data list

This indicates the time code values of the cue points.

1 00:00:28:23

2

3

Functions

□ Entering cue points

Up to 10 cue points can be entered.

- (1) Press the F6 (SETTING) key to set it to ON.
- (2) Select the cue number of the cue to be entered.
Press one of the F1 to F5 or F9 to F13 keys. The number corresponding to the button pressed is highlighted.
- (3) Input the time code.
There are 3 ways of inputting the time code.
 - 1) Search for the cue point using the search dial, and press the ENTRY IN or ENTRY OUT button.
 - 2) Input the time code directly using the number keys, and press the ENT key.
 - 3) Move the cursor to the section where the value is read.
 1. Press the FROM (F+2) key.
The time code at the cursor position is read into the scratchpad register.

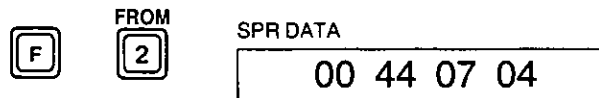

2. Increment or decrement the code using the "+" or "-" and a number key.



3. Press the ENT key.
The result of the operation is displayed.

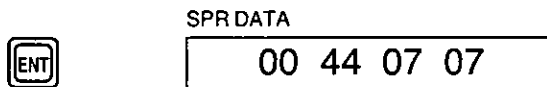

4. Move the cursor to the section where the time code which was read is to be displayed.

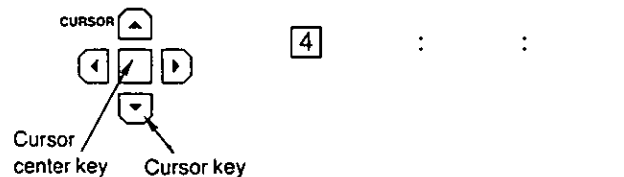

5. Press the COPY (F+1) key to call the time code which was read.

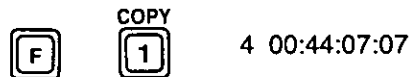

- (4) Press the F6 key to set it to OFF.
The cue data is now entered.

- The position of the next cue number is automatically highlighted when the F1 (AUTO STEP UP) key on the MULTI CUE (EXTEND) SET UP menu has been set to ON.
- Entered cues remain stored in the memory even when the power is turned off.

How to display the menus:

• MULTI CUE (EXTEND) SET UP menu:

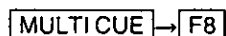

□ Changing cue points

Follow the steps given below to change a cue point which has already been entered.

- (1) Press the F6 (SETTING) key to set it to ON.
- (2) Press the key (F1 to F5 or F9 to F13) corresponding to the cue which is to be changed.
- (3) Press the cursor keys to move the cipher cursor to the time code of the cue which is to be changed.

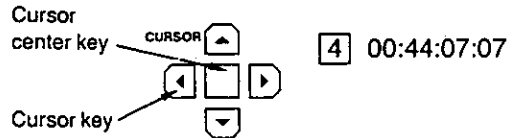

- (4) Press the cursor center key to change the cursor into the cipher cursor, and then input the value using the number keys.



- (5) Press the ENT key.

4 00:44:07:04

□ Clearing cue data

Follow the steps given below to clear a cue point which has already been entered.

- (1) Press the F6 (SETTING) key to set it to ON.
- (2) Press the key (F1 to F5 or F9 to F13) corresponding to the cue number which is to be cleared.
- (3) Press the C key.
- (4) Press the ENT key.

□ Clearing all the cue data

- (1) Press the F6 (SETTING) key to set it to ON.
- (2) Press the F key and F7 (ALL CLR) key together.

□ Cue search and preroll

- (1) Press the F6 (SETTING) key to set it to OFF.
 - (2) Press one of the F1 (cue no. 1) to F5 (cue no. 5) or F9 (cue no. 6) to F13 (cue no. 10) keys.
 - (3) Press the SEARCH or PREROLL button.
 - If the SEARCH button is pressed, the tape stops at the designated cue position.
 - If the PREROLL button is pressed, the tape is prerolled from the cue position, and it stops at the preroll point.
- If a cue is changed after the SEARCH button is pressed and while search is in progress, the changed position of the cue will be searched.

- Change or clear the cue points in the lock (protection) release status.

MULTI CUE (EXTEND) menu

This menu appears when the **MULTI CUE** key is pressed.

<< MULTI CUE : EXTEND >>
LTCR 00:00:00:00

| | | | | | | | | | | | | | | | | | | | | | | | | | | | | | | | | | | | | | | | | | | | | | | | | | | | | | | | | | | | | | | | | | | | | | | | | | | | | | | | | | | | | | | | | | | | | | | | | | | | | | | | | | | | | | | | | | | | | | | | | | | | | | |
|--|---------|----------------|--------|----------------------|-----|---|---|---|------|--|----|---|-------|---|----|-----|---|---|---|---|-----|---|---|---|---|-----|---|---|---|---|-----|---|---|---|---|-----|---|---|---|---|-----|---|---|---|---|----|---|---|---|---|--|---|------|----|-----|----|-------|-----|------|-----|---------|-----|-----|-----|-----|-----|-------|-----|-------|----|---------|---|---|---|---|---|---|---|---|---|---|---|---|---|---|---|---|---|---|---|---|---|---|---|---|---|---|---|---|---|---|---|--|---|---|---|---|---|---|---|---|---|---|---|---|----|---|---|---|--|----|---|---|---|---|
| <table border="0"> <tr><td>0</td><td>-</td><td>-</td><td>-</td><td>-</td></tr> <tr><td>-4</td><td>-</td><td>-</td><td>-</td><td>-</td></tr> <tr><td>-8</td><td>-</td><td>-</td><td>-</td><td>-</td></tr> <tr><td>-12</td><td>-</td><td>-</td><td>-</td><td>-</td></tr> <tr><td>-16</td><td>◀</td><td>◀</td><td>◀</td><td>◀</td></tr> <tr><td>-20</td><td>-</td><td>-</td><td>-</td><td>-</td></tr> <tr><td>-25</td><td>-</td><td>-</td><td>-</td><td>-</td></tr> <tr><td>-30</td><td>-</td><td>-</td><td>-</td><td>-</td></tr> <tr><td>-40</td><td>-</td><td>-</td><td>-</td><td>-</td></tr> <tr><td>-∞</td><td>-</td><td>-</td><td>-</td><td>-</td></tr> </table> | 0 | - | - | - | - | -4 | - | - | - | - | -8 | - | - | - | - | -12 | - | - | - | - | -16 | ◀ | ◀ | ◀ | ◀ | -20 | - | - | - | - | -25 | - | - | - | - | -30 | - | - | - | - | -40 | - | - | - | - | -∞ | - | - | - | - | <table border="0"> <tr><td>0</td><td>1000</td></tr> <tr><td>-4</td><td>REF</td></tr> <tr><td>-8</td><td>HD 59</td></tr> <tr><td>-12</td><td>TIME</td></tr> <tr><td>-16</td><td>1000 59</td></tr> <tr><td>-20</td><td>MEM</td></tr> <tr><td>-25</td><td>CH0</td></tr> <tr><td>-30</td><td>CMPST</td></tr> <tr><td>-40</td><td>EXPST</td></tr> <tr><td>-∞</td><td>SQUEEZE</td></tr> </table> | 0 | 1000 | -4 | REF | -8 | HD 59 | -12 | TIME | -16 | 1000 59 | -20 | MEM | -25 | CH0 | -30 | CMPST | -40 | EXPST | -∞ | SQUEEZE | <table border="0"> <tr><td>1</td><td>:</td><td>:</td><td>:</td><td>:</td></tr> <tr><td>2</td><td>:</td><td>:</td><td>:</td><td>:</td></tr> <tr><td>3</td><td>:</td><td>:</td><td>:</td><td>:</td></tr> <tr><td>4</td><td>:</td><td>:</td><td>:</td><td>:</td></tr> <tr><td>5</td><td>:</td><td>:</td><td>:</td><td>:</td></tr> <tr><td>6</td><td>:</td><td>:</td><td>:</td><td>:</td></tr> </table> | 1 | : | : | : | : | 2 | : | : | : | : | 3 | : | : | : | : | 4 | : | : | : | : | 5 | : | : | : | : | 6 | : | : | : | : | <table border="0"> <tr><td>7</td><td>:</td><td>:</td><td>:</td></tr> <tr><td>8</td><td>:</td><td>:</td><td>:</td></tr> <tr><td>9</td><td>:</td><td>:</td><td>:</td></tr> <tr><td>10</td><td>:</td><td>:</td><td>:</td></tr> </table> | 7 | : | : | : | 8 | : | : | : | 9 | : | : | : | 10 | : | : | : | <table border="0"> <tr><td>10</td></tr> <tr><td>9</td></tr> <tr><td>8</td></tr> <tr><td>7</td></tr> <tr><td>6</td></tr> </table> | 10 | 9 | 8 | 7 | 6 |
| 0 | - | - | - | - | | | | | | | | | | | | | | | | | | | | | | | | | | | | | | | | | | | | | | | | | | | | | | | | | | | | | | | | | | | | | | | | | | | | | | | | | | | | | | | | | | | | | | | | | | | | | | | | | | | | | | | | | | | | | | | | | | | | | | | | | |
| -4 | - | - | - | - | | | | | | | | | | | | | | | | | | | | | | | | | | | | | | | | | | | | | | | | | | | | | | | | | | | | | | | | | | | | | | | | | | | | | | | | | | | | | | | | | | | | | | | | | | | | | | | | | | | | | | | | | | | | | | | | | | | | | | | | | |
| -8 | - | - | - | - | | | | | | | | | | | | | | | | | | | | | | | | | | | | | | | | | | | | | | | | | | | | | | | | | | | | | | | | | | | | | | | | | | | | | | | | | | | | | | | | | | | | | | | | | | | | | | | | | | | | | | | | | | | | | | | | | | | | | | | | | |
| -12 | - | - | - | - | | | | | | | | | | | | | | | | | | | | | | | | | | | | | | | | | | | | | | | | | | | | | | | | | | | | | | | | | | | | | | | | | | | | | | | | | | | | | | | | | | | | | | | | | | | | | | | | | | | | | | | | | | | | | | | | | | | | | | | | | |
| -16 | ◀ | ◀ | ◀ | ◀ | | | | | | | | | | | | | | | | | | | | | | | | | | | | | | | | | | | | | | | | | | | | | | | | | | | | | | | | | | | | | | | | | | | | | | | | | | | | | | | | | | | | | | | | | | | | | | | | | | | | | | | | | | | | | | | | | | | | | | | | | |
| -20 | - | - | - | - | | | | | | | | | | | | | | | | | | | | | | | | | | | | | | | | | | | | | | | | | | | | | | | | | | | | | | | | | | | | | | | | | | | | | | | | | | | | | | | | | | | | | | | | | | | | | | | | | | | | | | | | | | | | | | | | | | | | | | | | | |
| -25 | - | - | - | - | | | | | | | | | | | | | | | | | | | | | | | | | | | | | | | | | | | | | | | | | | | | | | | | | | | | | | | | | | | | | | | | | | | | | | | | | | | | | | | | | | | | | | | | | | | | | | | | | | | | | | | | | | | | | | | | | | | | | | | | | |
| -30 | - | - | - | - | | | | | | | | | | | | | | | | | | | | | | | | | | | | | | | | | | | | | | | | | | | | | | | | | | | | | | | | | | | | | | | | | | | | | | | | | | | | | | | | | | | | | | | | | | | | | | | | | | | | | | | | | | | | | | | | | | | | | | | | | |
| -40 | - | - | - | - | | | | | | | | | | | | | | | | | | | | | | | | | | | | | | | | | | | | | | | | | | | | | | | | | | | | | | | | | | | | | | | | | | | | | | | | | | | | | | | | | | | | | | | | | | | | | | | | | | | | | | | | | | | | | | | | | | | | | | | | | |
| -∞ | - | - | - | - | | | | | | | | | | | | | | | | | | | | | | | | | | | | | | | | | | | | | | | | | | | | | | | | | | | | | | | | | | | | | | | | | | | | | | | | | | | | | | | | | | | | | | | | | | | | | | | | | | | | | | | | | | | | | | | | | | | | | | | | | |
| 0 | 1000 | | | | | | | | | | | | | | | | | | | | | | | | | | | | | | | | | | | | | | | | | | | | | | | | | | | | | | | | | | | | | | | | | | | | | | | | | | | | | | | | | | | | | | | | | | | | | | | | | | | | | | | | | | | | | | | | | | | | | | | | | | | | |
| -4 | REF | | | | | | | | | | | | | | | | | | | | | | | | | | | | | | | | | | | | | | | | | | | | | | | | | | | | | | | | | | | | | | | | | | | | | | | | | | | | | | | | | | | | | | | | | | | | | | | | | | | | | | | | | | | | | | | | | | | | | | | | | | | | |
| -8 | HD 59 | | | | | | | | | | | | | | | | | | | | | | | | | | | | | | | | | | | | | | | | | | | | | | | | | | | | | | | | | | | | | | | | | | | | | | | | | | | | | | | | | | | | | | | | | | | | | | | | | | | | | | | | | | | | | | | | | | | | | | | | | | | | |
| -12 | TIME | | | | | | | | | | | | | | | | | | | | | | | | | | | | | | | | | | | | | | | | | | | | | | | | | | | | | | | | | | | | | | | | | | | | | | | | | | | | | | | | | | | | | | | | | | | | | | | | | | | | | | | | | | | | | | | | | | | | | | | | | | | | |
| -16 | 1000 59 | | | | | | | | | | | | | | | | | | | | | | | | | | | | | | | | | | | | | | | | | | | | | | | | | | | | | | | | | | | | | | | | | | | | | | | | | | | | | | | | | | | | | | | | | | | | | | | | | | | | | | | | | | | | | | | | | | | | | | | | | | | | |
| -20 | MEM | | | | | | | | | | | | | | | | | | | | | | | | | | | | | | | | | | | | | | | | | | | | | | | | | | | | | | | | | | | | | | | | | | | | | | | | | | | | | | | | | | | | | | | | | | | | | | | | | | | | | | | | | | | | | | | | | | | | | | | | | | | | |
| -25 | CH0 | | | | | | | | | | | | | | | | | | | | | | | | | | | | | | | | | | | | | | | | | | | | | | | | | | | | | | | | | | | | | | | | | | | | | | | | | | | | | | | | | | | | | | | | | | | | | | | | | | | | | | | | | | | | | | | | | | | | | | | | | | | | |
| -30 | CMPST | | | | | | | | | | | | | | | | | | | | | | | | | | | | | | | | | | | | | | | | | | | | | | | | | | | | | | | | | | | | | | | | | | | | | | | | | | | | | | | | | | | | | | | | | | | | | | | | | | | | | | | | | | | | | | | | | | | | | | | | | | | | |
| -40 | EXPST | | | | | | | | | | | | | | | | | | | | | | | | | | | | | | | | | | | | | | | | | | | | | | | | | | | | | | | | | | | | | | | | | | | | | | | | | | | | | | | | | | | | | | | | | | | | | | | | | | | | | | | | | | | | | | | | | | | | | | | | | | | | |
| -∞ | SQUEEZE | | | | | | | | | | | | | | | | | | | | | | | | | | | | | | | | | | | | | | | | | | | | | | | | | | | | | | | | | | | | | | | | | | | | | | | | | | | | | | | | | | | | | | | | | | | | | | | | | | | | | | | | | | | | | | | | | | | | | | | | | | | | |
| 1 | : | : | : | : | | | | | | | | | | | | | | | | | | | | | | | | | | | | | | | | | | | | | | | | | | | | | | | | | | | | | | | | | | | | | | | | | | | | | | | | | | | | | | | | | | | | | | | | | | | | | | | | | | | | | | | | | | | | | | | | | | | | | | | | | |
| 2 | : | : | : | : | | | | | | | | | | | | | | | | | | | | | | | | | | | | | | | | | | | | | | | | | | | | | | | | | | | | | | | | | | | | | | | | | | | | | | | | | | | | | | | | | | | | | | | | | | | | | | | | | | | | | | | | | | | | | | | | | | | | | | | | | |
| 3 | : | : | : | : | | | | | | | | | | | | | | | | | | | | | | | | | | | | | | | | | | | | | | | | | | | | | | | | | | | | | | | | | | | | | | | | | | | | | | | | | | | | | | | | | | | | | | | | | | | | | | | | | | | | | | | | | | | | | | | | | | | | | | | | | |
| 4 | : | : | : | : | | | | | | | | | | | | | | | | | | | | | | | | | | | | | | | | | | | | | | | | | | | | | | | | | | | | | | | | | | | | | | | | | | | | | | | | | | | | | | | | | | | | | | | | | | | | | | | | | | | | | | | | | | | | | | | | | | | | | | | | | |
| 5 | : | : | : | : | | | | | | | | | | | | | | | | | | | | | | | | | | | | | | | | | | | | | | | | | | | | | | | | | | | | | | | | | | | | | | | | | | | | | | | | | | | | | | | | | | | | | | | | | | | | | | | | | | | | | | | | | | | | | | | | | | | | | | | | | |
| 6 | : | : | : | : | | | | | | | | | | | | | | | | | | | | | | | | | | | | | | | | | | | | | | | | | | | | | | | | | | | | | | | | | | | | | | | | | | | | | | | | | | | | | | | | | | | | | | | | | | | | | | | | | | | | | | | | | | | | | | | | | | | | | | | | | |
| 7 | : | : | : | | | | | | | | | | | | | | | | | | | | | | | | | | | | | | | | | | | | | | | | | | | | | | | | | | | | | | | | | | | | | | | | | | | | | | | | | | | | | | | | | | | | | | | | | | | | | | | | | | | | | | | | | | | | | | | | | | | | | | | | | | |
| 8 | : | : | : | | | | | | | | | | | | | | | | | | | | | | | | | | | | | | | | | | | | | | | | | | | | | | | | | | | | | | | | | | | | | | | | | | | | | | | | | | | | | | | | | | | | | | | | | | | | | | | | | | | | | | | | | | | | | | | | | | | | | | | | | | |
| 9 | : | : | : | | | | | | | | | | | | | | | | | | | | | | | | | | | | | | | | | | | | | | | | | | | | | | | | | | | | | | | | | | | | | | | | | | | | | | | | | | | | | | | | | | | | | | | | | | | | | | | | | | | | | | | | | | | | | | | | | | | | | | | | | | |
| 10 | : | : | : | | | | | | | | | | | | | | | | | | | | | | | | | | | | | | | | | | | | | | | | | | | | | | | | | | | | | | | | | | | | | | | | | | | | | | | | | | | | | | | | | | | | | | | | | | | | | | | | | | | | | | | | | | | | | | | | | | | | | | | | | | |
| 10 | | | | | | | | | | | | | | | | | | | | | | | | | | | | | | | | | | | | | | | | | | | | | | | | | | | | | | | | | | | | | | | | | | | | | | | | | | | | | | | | | | | | | | | | | | | | | | | | | | | | | | | | | | | | | | | | | | | | | | | | | | | | | |
| 9 | | | | | | | | | | | | | | | | | | | | | | | | | | | | | | | | | | | | | | | | | | | | | | | | | | | | | | | | | | | | | | | | | | | | | | | | | | | | | | | | | | | | | | | | | | | | | | | | | | | | | | | | | | | | | | | | | | | | | | | | | | | | | |
| 8 | | | | | | | | | | | | | | | | | | | | | | | | | | | | | | | | | | | | | | | | | | | | | | | | | | | | | | | | | | | | | | | | | | | | | | | | | | | | | | | | | | | | | | | | | | | | | | | | | | | | | | | | | | | | | | | | | | | | | | | | | | | | | |
| 7 | | | | | | | | | | | | | | | | | | | | | | | | | | | | | | | | | | | | | | | | | | | | | | | | | | | | | | | | | | | | | | | | | | | | | | | | | | | | | | | | | | | | | | | | | | | | | | | | | | | | | | | | | | | | | | | | | | | | | | | | | | | | | |
| 6 | | | | | | | | | | | | | | | | | | | | | | | | | | | | | | | | | | | | | | | | | | | | | | | | | | | | | | | | | | | | | | | | | | | | | | | | | | | | | | | | | | | | | | | | | | | | | | | | | | | | | | | | | | | | | | | | | | | | | | | | | | | | | |
| <table border="0"> <tr> <td>LR LR LR LR LR</td> <td>VID IN</td> </tr> <tr> <td>AES AES AES AES LINE</td> <td>DIG</td> </tr> </table> | | LR LR LR LR LR | VID IN | AES AES AES AES LINE | DIG | <table border="0"> <tr> <td>1</td> <td>PAGE</td> </tr> </table> | | 1 | PAGE | <table border="0"> <tr> <td>-</td> <td>STILL</td> <td>+</td> </tr> <tr> <td colspan="3" style="text-align: center;">▶▶</td> </tr> </table> | | - | STILL | + | ▶▶ | | | | | | | | | | | | | | | | | | | | | | | | | | | | | | | | | | | | | | | | | | | | | | | | | | | | | | | | | | | | | | | | | | | | | | | | | | | | | | | | | | | | | | | | | | | | | | | | | | | | | | | | | | | | | | |
| LR LR LR LR LR | VID IN | | | | | | | | | | | | | | | | | | | | | | | | | | | | | | | | | | | | | | | | | | | | | | | | | | | | | | | | | | | | | | | | | | | | | | | | | | | | | | | | | | | | | | | | | | | | | | | | | | | | | | | | | | | | | | | | | | | | | | | | | | | | |
| AES AES AES AES LINE | DIG | | | | | | | | | | | | | | | | | | | | | | | | | | | | | | | | | | | | | | | | | | | | | | | | | | | | | | | | | | | | | | | | | | | | | | | | | | | | | | | | | | | | | | | | | | | | | | | | | | | | | | | | | | | | | | | | | | | | | | | | | | | | |
| 1 | PAGE | | | | | | | | | | | | | | | | | | | | | | | | | | | | | | | | | | | | | | | | | | | | | | | | | | | | | | | | | | | | | | | | | | | | | | | | | | | | | | | | | | | | | | | | | | | | | | | | | | | | | | | | | | | | | | | | | | | | | | | | | | | | |
| - | STILL | + | | | | | | | | | | | | | | | | | | | | | | | | | | | | | | | | | | | | | | | | | | | | | | | | | | | | | | | | | | | | | | | | | | | | | | | | | | | | | | | | | | | | | | | | | | | | | | | | | | | | | | | | | | | | | | | | | | | | | | | | | | | |
| ▶▶ | | | | | | | | | | | | | | | | | | | | | | | | | | | | | | | | | | | | | | | | | | | | | | | | | | | | | | | | | | | | | | | | | | | | | | | | | | | | | | | | | | | | | | | | | | | | | | | | | | | | | | | | | | | | | | | | | | | | | | | | | | | | | |
| | | PROTECT | | SET UP | | | | | | | | | | | | | | | | | | | | | | | | | | | | | | | | | | | | | | | | | | | | | | | | | | | | | | | | | | | | | | | | | | | | | | | | | | | | | | | | | | | | | | | | | | | | | | | | | | | | | | | | | | | | | | | | | | | | | | | | | |

F1

F2

F3

F4

F5

F6

F7

F8

F13

F12

F11

F10

F9

Function keys

| Key | Item | Function |
|-----|-----------------------------|--|
| F1 | Cue no. 1 assignment | This assigns cue no. 1. |
| F2 | Cue no. 2 assignment | This assigns cue no. 2. |
| F3 | Cue no. 3 assignment | This assigns cue no. 3. |
| F4 | Cue no. 4 assignment | This assigns cue no. 4. |
| F5 | Cue no. 5 assignment | This assigns cue no. 5. |
| F6 | PROTECT Page lock ON/OFF | This switches the page locking function ON and OFF when it is pressed together with the F key. ON: Cue points on the page concerned cannot be entered, changed or deleted. OFF: Cue points on the page concerned can be entered, changed or deleted. |
| F7 | — | |
| F8 | SET UP | This transfers operation to the MULTI CUE SET UP menu. |
| F9 | Cue no. 6 assignment | This assigns cue no. 6. |
| F10 | Cue no. 7 assignment | This assigns cue no. 7. |
| F11 | Cue no. 8 assignment | This assigns cue no. 8. |
| F12 | Cue no. 9 assignment | This assigns cue no. 9. |
| F13 | Cue no. 10 assignment | This assigns cue no. 10. |

Functions

□ Selecting a page

- When any key from F1 (cue no. 1) to F5 (cue no. 5) or F9 (cue no. 6) to F13 (cue no. 10) keys and the F key are pressed together, the corresponding page can be selected.
- The page number selected is incremented when the F and ► keys are pressed together.
- The page number selected is decremented when the F and ◀ keys are pressed together.
Page 10 appears when the page number is decremented from page 1.
Page 1 appears when the page number is incremented from page 10.

4 PAGE

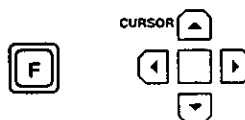

□ Page protection

- When the F and F6 (PROTECT) keys are pressed together, the protection status is set for the page displayed.
When these two keys are pressed together again, the protection status is released.
When a page is protected, its number appears as shown below.

Page protected

1 PAGE

Page protection released

1 PAGE

□ Entering, changing or deleting cues

The procedure is the same as for steps (2) and (3) for entering cues, steps (2) to (5) for changing cues, and steps (2) to (4) for clearing cues on the MULTI CUE (USER) menu.

□ Clearing all the cues

First press the F8 (SET UP) key, and then press the F3 (PAG CLR) key on the SET UP menu and F key together. All the cues on the page will be cleared. If the F5 (ALL CLR) key and F key are pressed together, the cues on all the pages will be cleared. (However, cues on protected pages cannot be cleared.)

MULTI CUE (EXTEND) SET UP menu

This menu appears when the **MULTI CUE** key and then the **F8** key are pressed.

▶ ▶ ▶ ▶

| | | | | | | | |
|-----|---|---|---|---|---|---|---|
| 0 | | | | | | | |
| -4 | - | - | - | - | - | - | - |
| -8 | - | - | - | - | - | - | - |
| -12 | - | - | - | - | - | - | - |
| -16 | ◀ | ◀ | ◀ | ◀ | - | - | - |
| -20 | - | - | - | - | - | - | - |
| -25 | - | - | - | - | - | - | - |
| -30 | - | - | - | - | - | - | - |
| -40 | - | - | - | - | - | - | - |
| -∞ | - | - | - | - | - | - | - |

<< MULTI CUE : EXTEND : SET UP >>

LTCR 00:00:00:00

| | | | | | |
|-----|----------|--|--|--|----------|
| 0 | 1000 | | | | |
| -4 | REF | | | | PREROLL |
| -8 | HD 59 | | | | 5 SEC |
| -12 | TSEE | | | | |
| -16 | 1000 59 | | | | AUTO FRZ |
| -20 | WFM | | | | OFF |
| -25 | CH0 | | | | MAX SP. |
| -30 | CLIPDOWN | | | | -1↔+2 |
| -35 | COMPST | | | | CLUTCH |
| -40 | ASPECT | | | | OFF |
| -∞ | SQUEEZE | | | | EXIT |

| | | | | | |
|------------------------------|------------------------------|------------------------------|------------------------------|-------------------------------|--|
| <input type="checkbox"/> VR | <input type="checkbox"/> LF | <input type="checkbox"/> OR | <input type="checkbox"/> LR | <input type="checkbox"/> LR | |
| <input type="checkbox"/> AES | <input type="checkbox"/> AES | <input type="checkbox"/> AES | <input type="checkbox"/> AES | <input type="checkbox"/> LINE | |

| | | | | | |
|---------------------------------|------------------------------|------------------------------|------------------------------|---------|---------|
| <input type="checkbox"/> VID IN | <input type="checkbox"/> DIG | AUTO STEP | PAG MODE | PAG CLR | ALL CLR |
| | | <input type="checkbox"/> OFF | <input type="checkbox"/> OFF | | |

- F13
- F12
- F11
- F10
- F9

- F1
- F2
- F3
- F4
- F5
- F6
- F7
- F8

- 96 -

Function keys

| Key | Item | Function |
|-------|---|--|
| F1 | AUTO STEP Auto step mode ON/OFF | <p>ON: The cursor automatically moves to the next item when a cue point has been entered.</p> <p>OFF: The cursor does not move.</p> <ul style="list-style-type: none"> •When the F2 (PAG MODE) key below is ON, the cursor moves only within the page on the screen. For instance, when the entry of cue no. 10 is completed, the cursor moves to the time code input position of cue No. 1 on the same page. •When the F2 (PAG MODE) key below is OFF, the cursor moves between pages. For instance, when the entry of cue no. 10 is completed, the cursor moves to the time code input position of cue No. 1 on the next page. |
| F2 | PAG MODE Cursor movement mode setting | <p>ON: The cursor movement is confined to the same page.</p> <p>OFF: The cursor can move between pages.</p> |
| F3 | PAG CLR Clearing of cue data within page | <p>When this key and the F key are pressed together, all the cue data entered on a page is cleared.</p> <ul style="list-style-type: none"> •Data on protected pages is not cleared. |
| F4 | — | |
| F5 | ALL CLR Clearing of all cue data | <p>When this key and the F key are pressed together, all cue data is cleared.</p> <ul style="list-style-type: none"> •Data on protected pages is not cleared. |
| F6-F7 | — | |
| F8 | EXIT | Operation is returned to the MULTI CUE (EXTEND) menu. |
| F9 | CLUTCH Dial clutch ON/OFF in variable mode | <p>ON: The dial clutch is set to $-1\times$, $0\times$, $+1\times$ or $+2\times$ normal tape speed.</p> <p>OFF: The clutch is not set.</p> |
| F10 | MAX SP Maximum tape speed selection in variable mode | <p>$-1\leftrightarrow+2$: Tape speed ranges from $-1\times$ to $+2\times$ normal speed. ($-1\leftrightarrow+3$ for tapes recorded in a D-3 series machine)</p> <p>$-1\leftrightarrow+1$: Tape speed ranges from $-1\times$ to $+1\times$ normal speed.</p> <p>$0\leftrightarrow+1$: Tape speed ranges from $0\times$ to $+1\times$ normal speed.</p> |
| F11 | AUTO FRZ Auto Freeze | <p>ON: When the EXECUTE button is pressed during a VAR mode operation, freeze-frames are played back. (The tape continues to travel.)</p> <p>OFF: No freeze-frame playback The freeze-frame is released when any of the tape transport buttons (STOP, PLAY, FF, REW, JOG, VAR or SHTL) is pressed.</p> |
| F12 | — | |
| F13 | PREROLL Preroll time selection | This enables the preroll time to be selected in 1-second increments from 0 to 30 seconds. |

INSERT/ASSEMBLE MANUAL EDIT menu

This menu appears when the **ASSEMBLE** or **INSERT** key is pressed, and then the **F12** key is pressed to set it to MANUAL EDIT.

The interface includes the following elements:

- Vertical Scale:** Levels from 0 to -40, with markers at 0, -4, -8, -12, -16, -20, -25, -30, -40, and -∞.
- Top Controls:** XFADE, INTRP, and MAN EDIT.
- Time Displays:** LTCR (00:00:00:00), CUE TIME (H M S F), and REMAINING TIME (H M).
- File and Status:** USER FILE NO: LAST, STILL indicator.
- Channel and Video Settings:** VIDEO, CH-1, CH-2, CH-3, CH-4, CUE, TC (all OFF).
- Function Keys:** F1-F8 at the bottom, F9-F13 on the right.

Function keys

| Key | Item | Function |
|---------|--|--|
| F1 | VIDEO Video channel ON/OFF | |
| F2 | CH-1 Audio channel CH1 ON/OFF | |
| F3 | CH-2 Audio channel CH2 ON/OFF | <p>These functions select the edit channels and are valid only during insert editing.</p> <p>ON: Channel is selected as the edit channel. OFF: Channel is not selected as the edit channel.</p> <p>● A stable video input signal must be left connected even when only the digital audio channels have been selected for insert editing. If the video input signal is disturbed, the sound may not be recorded properly.</p> |
| F4 | CH-3 Audio channel CH3 ON/OFF | |
| F5 | CH-4 Audio channel CH4 ON/OFF | |
| F6 | CUE Analog cue channel ON/OFF | |
| F7 | TC Time code channel ON/OFF | |
| F8 | SET UP | This transfers operation to the INSERT/ASSEMBLE MANUAL EDIT SET UP menu. |
| F9 | INSERT/ASSEMBLE Editing mode ON/OFF | When the display is highlighted, the editing mode is set ON. |
| F10–F11 | — | |
| F12 | AUTO/MANUAL EDIT Editing method setting | AUTO EDIT: This transfers operation to the AUTO EDIT menu. MANUAL EDIT: For manual editing. |
| F13 | — | |

INSERT/ASSEMBLE MANUAL EDIT SET UP menu

This menu appears when the **ASSEMBLE** or **INSERT** key is pressed followed by the **F1** key and then by the **F8** key.

Alternatively, it appears when the **SET UP** key and then the **F2** key are pressed.

The screenshot shows a complex menu interface for manual editing. At the top, it displays 'MAN EDIT : SET UP' and 'EDIT REC INHIBIT'. On the left, there are two vertical scales from 0 to -∞, with various menu options like '1035', 'FREE', 'INT59', 'TAP', '1035 59', 'REF', 'CH0', 'COMBOW', 'CMPST', 'SQUEEZE', 'VID IN', and 'DIG'. The center contains a 'SOFTWARE' section with 'VIDEO' and 'CH1-CH4' options, and a 'HOME' section with 'FREE', 'NRML REC', and 'ALL' options. To the right is a 'CASSETTE' section with 'FREE' and 'VID/CNTL' options. Further right is a 'REC ENV' section with a vertical scale from 1 to 5 and a 'STILL' indicator. On the far right, there is a 'MODE' section with 'XFADE', 'FD TIME' (5 mS), 'TRACKING OPT. ONCE', 'ERR. STP', and 'EXIT' options. Below the main menu area, there are two rows of function key overlays: F1-F8 at the bottom and F9-F13 on the right side.

Function keys

| Key | Item | Function |
|-------|--|---|
| F1 | TIMING Edit timing setting (This function can be selected by pressing the F and F1 keys together.) | <p>F1: Editing starts from the odd-numbered field at the player's IN point and ends after the even-numbered field which is one frame before the OUT point is recorded.</p> <p>F2: Editing starts from the even-numbered field at the player's IN point and ends after the odd-numbered field at the OUT point is recorded.</p> <p>F1/F2: The edit IN and OUT point fields are determined by the timing at which the edit command is output. If the edit timing is output in an even-numbered field, editing is concluded in an odd-numbered field; conversely, if it is output in an odd-numbered field, it is concluded in an even-numbered field.</p> <ul style="list-style-type: none"> • The edit timing can also be set on the AUTO EDIT SET UP menu. If a different mode has been set on the AUTO EDIT SET UP menu, the mode set on this menu will also be changed. |
| F2-F7 | — | |
| F8 | EXIT | Operation is returned to the INSERT/ASSEMBLE MANUAL EDIT menu. |
| F9 | ERR.STP Error stop | <p>ON: When an error has occurred at any point up to the IN point during editing in the optimize mode, the editing is stopped and the unit is placed in the stop mode.</p> <p>OFF: The error message is displayed but editing is continued.</p> |
| F10 | TRACKING Tracking adjustment | <p>Normally, tracking does not need to be adjusted. This key is used to adjust the tracking when it has shifted during editing.</p> <p>VAR: The tracking is adjusted manually. Refer to "Adjusting the tracking manually" on page 105.</p> <p>FIX: The tracking is fixed.</p> <p>OPT ONCE: The tracking is optimized during playback up to the IN point for the first editing operation after inserting the cassette. It is subsequently not optimized. It is possible to optimize the tracking again. Refer to "Adjusting the tracking automatically" on page 104.</p> <p>OPT AUTO: The tracking is optimized during playback up to each IN point each time editing is performed. Refer to "Adjusting the tracking automatically".</p> |
| F11 | — | |
| F12 | FD TIME Audio fade time setting | <p>This function is valid when the F1 key is set to X FADE or V FADE. The time can be set to 5, 10, 15, 20, 25, 50 or 100 ms (default setting: 5 ms). For details on the setting, refer to "Selecting the audio fade time" on page 106.</p> |
| F13 | MODE Audio fade edit mode setting | <p>This enables audio signals to be edited while cross-fading or V-fading the preceding playback sound and input sound.</p> <p>X FADE: For audio cross-fade editing.</p> <p>CUT: For cut editing (normal editing).</p> <p>V FADE: For audio V fade editing.</p> <ul style="list-style-type: none"> • If audio mixing recording has been selected [F6 (CH-MIX) key set to ON on the AUDIO IN SET UP menu], cut editing will occur automatically, even if X FADE or V FADE have been selected. |

Displays and functions

EDIT REC INHIBIT mode display

This display indicates the edit inhibit mode statuses.

| EDIT REC INHIBIT | | |
|------------------|----------|----------|
| SOFTWARE | HOME | CASSETTE |
| VIDEO | FREE | FREE |
| CH1 | NRML REC | VID/CNTL |
| CH2 | ALL | ALL |
| CH3 | | |
| CH4 | | |
| CUE | | |
| TC | | |

● SOFTWARE

This part of the indicates the edit inhibit modes which have been selected for each channel. Refer to "Selecting the SOFTWARE inhibit channel".

- VIDEO:** Video channel editing is inhibited.
- CH1-CH4:** Digital audio channel editing is inhibited.
- CUE:** Cue channel editing is inhibited.
- TC:** Time code channel editing is inhibited.

● HOME

This part of the display indicates the recording inhibit mode which has been selected by the F13 (REC INH) key on the HOME menu.

- FREE:** Recording is possible.
- NRML REC:** The normal recording mode is inhibited.
- ALL:** All recording and editing operations are inhibited.

● CASSETTE

This part of the display indicates the recording inhibit mode which has been set on the cassette tape.

- FREE:** Recording is possible.
- VID/CNTL:** The video and control signals are inhibited.
- ALL:** All recording and editing operations are inhibited.

Sequence of priority for inhibit modes

A sequence of priority applies to the above inhibit modes and, depending on the selections made, recording may not be possible. For instance, when ALL has been selected for CASSETTE, editing and recording cannot be performed no matter what has been selected for SOFTWARE or HOME SETUP.

| | |
|-----|----------|
| 1st | CASSETTE |
| 2nd | HOME |
| 3rd | SOFTWARE |

Selecting the SOFTWARE inhibit channel

- (1) Press the cursor center key.
The cursor appears.

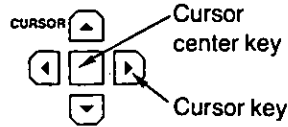

- (2) Press the cursor keys to move the cursor to the channel whose editing is to be inhibited.

CH4

- (3) Press the cursor center key. If the display is highlighted, it means that the selection of the edit inhibit channel is completed.
If the cursor center key is pressed again, the edit inhibit mode is released.

CH4

- Bear in mind that assemble editing is not possible as long as there is even one edit inhibit channel.

Notes:

- When either CASSETTE EDIT REC INHIBIT or HOME REC INHIBIT has been set to ALL, all recording and editing operations are inhibited.
- When CASSETTE EDIT REC INHIBIT has been set to VIDEO/CNTL, video channel editing is inhibited at all times.

REC ENV display

This displays the recording envelope during editing.

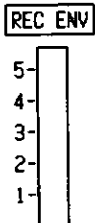

Tracking

Adjusting (optimizing) the tracking automatically

To optimize the tracking automatically, press the F10 (TRACKING) key to set it to OPT ONCE or OPT AUTO. Set the preroll time to at least 5 seconds.

- OPT ONCE is the setting for optimizing the tracking only once during playback up to the IN point for the first editing operation after inserting the cassette. The tracking is not optimized after this, and its value remains fixed.
- OPT AUTO is the setting for optimizing the tracking during playback up to the IN point for each editing operation.

Notes:

- The OPT ONCE setting is suitable when conducting continuous editing such as that shown below. (If OPT AUTO is set for this kind of editing, the tracking error can be accumulated.)

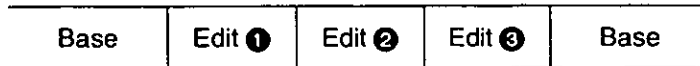

- The OPT AUTO setting is suitable when conducting intermittent editing such as that shown below.

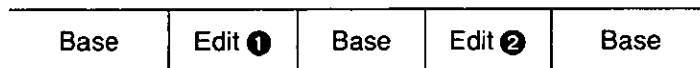

- Proceed as described below to optimize the tracking again at the OPT ONCE setting.

- (1) Press the INSERT or ASSEMBLE button, highlight the F9 key, and establish the editing mode. Check that the INSERT or ASSEMBLE LED has lighted.



- (2) Press the PLAY button to establish the PLAY (EDIT PLAY) mode.
- (3) The tracking is optimized when PLAY and READY are pressed together.

Notes:

- (1) The optimized tracking value is retained even when operation has been transferred to another menu.
- (2) The message shown below appears during optimizing, and the mark indicating the tracking value shows the stage of the processing.

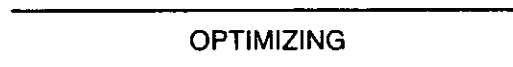

When optimizing is completed, the message shown below appears, and TRACK OPT appears on the INSERT/ASSEMBLE MANUAL EDIT or HOME menu screen.



How to display the menus:

•HOME menu:



- (3) In the cases described below, the following message appears, and optimizing is suspended.
- When the unit has been placed in any mode other than PLAY during the optimizing process
 - When optimizing has failed
 - When video signals have not been recorded on the tape
 - When the CTL signal has not been recorded on the tape

NOT COMPLETE

In this case, the center value (zero) is indicated as the tracking value.

•Notes on “Adjusting the tracking automatically” (continued)

- (4) If optimizing is continued for 5 seconds or longer but the process is still not completed, the message shown below appears and optimizing is suspended.

TIME OVER

- (5) When the cassette is ejected, the optimize value is canceled.

□ Adjusting the tracking manually

- (1) Load the tape and play it back.
- (2) Press the F10 (TRACKING) key to set it to VAR.

TRACKING
VAR

- (3) Turn the ADJUST control to the position where the envelope level is at its highest.

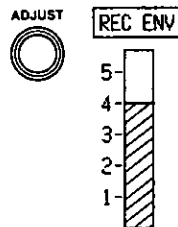

□ **Selecting the audio fade time**

(1) Press the F13 (MODE) key to set it to X FADE or V FADE.

MODE

X FADE

(2) Press the F12 (FD TIME) key.

FD TIME

10

(3) Select the audio fade time by turning the ADJUST control.

ADJUST



25

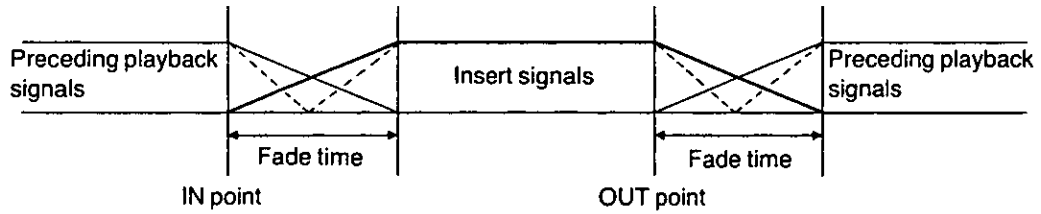

(—): X FADE
 (---): V FADE

INSERT/ASSEMBLE AUTO EDIT menu

This menu appears when the **ASSEMBLE** or **INSERT** key is pressed and then the **F12** key is set to AUTO EDIT.

| | | | | |
|---|--|---|--|---|
| <div style="display: flex; justify-content: space-between;"> 0 << AUTO EDIT >> </div> | | <div style="display: flex; justify-content: space-between;"> IN : : : OUT : : : </div> | <div style="display: flex; justify-content: space-between;"> RECORDER 00:00:00:00 VIDEO </div> | <div style="display: flex; justify-content: space-between;"> CH SELECT F13 </div> |
| <div style="display: flex; justify-content: space-between;"> -4 -4 </div> | <div style="display: flex; justify-content: space-between;"> HD 59 1000 59 </div> | <div style="display: flex; justify-content: space-between;"> V IN : : : V OUT : : : </div> | <div style="display: flex; justify-content: space-between;"> PLAYER-1 : : : CH1 CH2 CH3 CH4 </div> | <div style="display: flex; justify-content: space-between;"> MANUAL EDIT F12 </div> |
| <div style="display: flex; justify-content: space-between;"> -8 -8 </div> | <div style="display: flex; justify-content: space-between;"> TPE WFM </div> | <div style="display: flex; justify-content: space-between;"> P IN : : : P OUT : : : </div> | <div style="display: flex; justify-content: space-between;"> DURATION : : : CUE TC </div> | <div style="display: flex; justify-content: space-between;"> SPOT ERASE F11 </div> |
| <div style="display: flex; justify-content: space-between;"> -12 -12 </div> | <div style="display: flex; justify-content: space-between;"> CH0 APERT </div> | | | <div style="display: flex; justify-content: space-between;"> SPLIT F10 </div> |
| <div style="display: flex; justify-content: space-between;"> -16 -16 </div> | <div style="display: flex; justify-content: space-between;"> COMPST SQUEEZE </div> | | | <div style="display: flex; justify-content: space-between;"> INSERT F9 </div> |
| <div style="display: flex; justify-content: space-between;"> -20 -20 </div> | <div style="display: flex; justify-content: space-between;"> VID IN DIG </div> | | | |
| <div style="display: flex; justify-content: space-between;"> -25 -25 </div> | <div style="display: flex; justify-content: space-between;"> AES AES AES AES LINE </div> | <div style="display: flex; justify-content: space-between;"> LAST X LAST ED W/PLYR VAR MEMO PLYR SEL R/P SEL TRIM </div> | <div style="display: flex; justify-content: space-between;"> OFF OFF OFF OFF PLYR-1 RECORDER OFF </div> | |
| <div style="display: flex; justify-content: space-between;"> -30 -30 </div> | | | | |
| <div style="display: flex; justify-content: space-between;"> -40 -40 </div> | | | | |
| <div style="display: flex; justify-content: space-between;"> -∞ -∞ </div> | | | | |

F1

F2

F3

F4

F5

F6

F7

F8

Function keys

| Key | Item | Function |
|-----|--|--|
| F1 | LAST X Accessing of edit data which was last input | LOAD: The edit data which was last input is accessed. OFF: The LAST X function is released. |
| F2 | LAST ED Accessing of all data which was last edited | LOAD: All the data which was last-edited is accessed. OFF: The LAST ED function is released. |
| F3 | W/PLYR Connected VTR remote control ON/OFF | This function enables the RS-422A-connected VTR to be remote controlled. ON: Remote control is possible. OFF: The unit operates independently. •Refer also to the F6 (R/P SEL) key on the INSERT/ASSEMBLE AUTO EDIT menu. |
| F4 | VAR MEMO Variable memory | This function enables the playback speed and direction based on the search dial operation to be stored in the memory and the same operation to be reproduced during automatic editing. |
| F5 | PLYR SEL Selection of player to be remote-controlled | PLYR-1: The VTR connected to the REMOTE OUT connector is operated by remote control. PLYR-2: The VTR connected to the REMOTE IN/OUT connector is operated by remote control. |
| F6 | R/P SEL Selection of VTR to be operated | PLAYER: This exercises remote control over the player selected by the F5 (PLYR SEL) key. RECORDER: This unit (recorder) only is controlled. |
| F7 | TRIM Edit point frame trimming | ON: The entered edit point is trimmed in frame increments. Refer to "Trimming operation". OFF: The trimming function is released. |
| F8 | SET UP | Operation is transferred to the INSERT/ASSEMBLE AUTO EDIT SET UP menu. |
| F9 | INSERT/ASSEMBLE Editing mode ON/OFF | When the display is highlighted, the editing mode is ON. |
| F10 | SPLIT Split edit ON/OFF | This function enables the video and audio edit points to be entered individually during insert editing. ON: Split editing is set ON. OFF: Split editing is released. |
| F11 | SPOT ERS Spot erase ON/OFF | This function is valid only when this menu has been entered with the INSERT button (INSERT AUTO EDIT). ON: Part of the digital audio channel signals is erased in frame increments. OFF: The spot erase function is released. •Spot erase cannot be performed for the analog cue channel. |
| F12 | AUTO/MANUAL EDIT Editing method setting | AUTO EDIT: For automatic editing. Refer to the section on automatic editing. MANUAL EDIT: Operation is transferred to the INSERT/ASSEMBLE MANUAL EDIT menu. |
| F13 | CH SELECT Edit channel selection | When this is pressed, operation is transferred to the edit channel selection menu. (This functions in the insert editing mode only.) |

Displays and functions

Selecting the edit channel

- (1) Press the F13 (CH SELECT) key to display the edit channel selection menu.
- (2) Press the F1 (VIDEO) to F7 (TC) keys to select the edit channels.
- (3) Press the F13 key to return to the previous INSERT AUTO EDIT menu.
The selected channels are highlighted on the edit channel display.

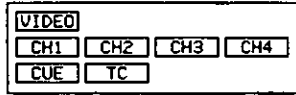

Tape position indicator

This indicates the edit points (IN/OUT) of the recorder and player, and the tape position.

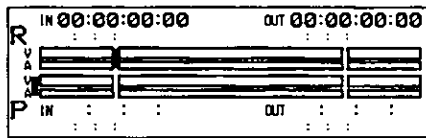

- BOT (beginning of tape) or EOT (end of tape) appears when the tape is positioned at the beginning (BOT) or end of the tape (EOT).
- The audio and video edit points are displayed separately during split editing.

Duration

RECORDER 00:05:53:04
 PLAYER-1 : : : :
 DURATION : : : :

When the duration is known, if only the IN point or OUT point is entered for the edit points of the recorder and player, the rest of the points will be calculated automatically.

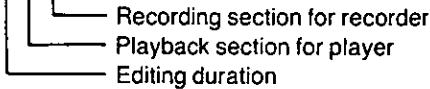

Edit data input section

□ Entering the edit points

(1) Input the points directly using the number keys.

- 1) Press the cursor center key.
The cursor appears.

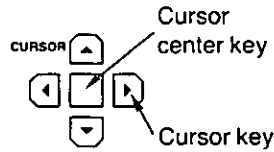

- 2) Press the cursor keys to move the cursor to the data input position. (The figure shows the player's IN point.)

IN : : :
P

- 3) Press the cursor center key.
The cursor changes to a cipher cursor.

IN 0 : : :
P

- 4) Input the edit points using the number keys.

- 5) Press the ENT key.
Follow the same procedure to enter the IN and OUT points for the recorder and player.

- Three of the total of four edit points for the recorder and player need to be entered. (Refer to "Duration".)
- **To delete data**, press the cursor keys to move the cursor to the position where the data is to be deleted, and press the C key.

□ Entering the edit points (continued)

- (2) Search for the edit point using the search dial.
 - 1) Search for the edit point using the search dial.
 - 2) Press the ENTRY IN or ENTRY OUT button.

● Trimming operation

- (1) Press the cursor center key.
The cursor appears.

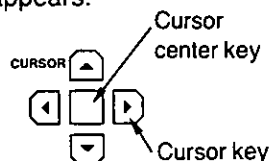

- (2) Press the cursor keys to move the cursor to the part of the data which is to be corrected.

IN 00:00:02:14

R

- (3) Set the F7 (TRIM) key to ON.

TRIM
ON

- (4) Press + or – key while pressing down the F key to correct the data in frame increments.
 - The number is incremented by 1 each time the + key is pressed while the F key is held down.
 - It is automatically and continuously incremented when the + key is kept depressed while the F key is held down.

- (5) Press the F7 (TRIM) key to set it to OFF.

TRIM
OFF

IN 00:00:02:16

R

Notes:

When the edit points are entered during player/recorder editing, the last edit point (4th point) is automatically calculated on the basis of the other three edit points, and this is entered as an imaginary edit point.

- An asterisk (*) appears alongside the imaginary edit point display.
- The imaginary edit point will be cleared automatically when the other edit points are cleared.

● **Input the data in the scratchpad register.**

- (1) Press the cursor center key.
The cursor appears.

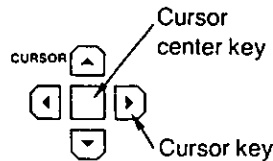

- (2) Press the cursor keys to move the cursor to the IN or OUT position of the time code which is to be input.
- (3) Press the FROM (F+2) key.
The time code at the cursor position is displayed inside the register.

SPR

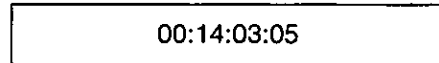

- (4) Press the +, -, number keys and ENT to add or subtract.
The calculation result is displayed inside the register.
- (5) Press the cursor keys to move the cursor to the position (IN or OUT) where the calculation result is to be copied.
- (6) Press the COPY (F+1) key.
The changed edit point time code is now displayed.

Notes:

- The following error message appears if an illegal number was input for the adding or subtracting in step 4).

ERROR INVALID TC DATA

- Correction is possible until the COPY (F+1) key is pressed.

□ **Accessing the edit data which was input last**

- (1) Press the cursor center key.
The cursor appears.
- (2) Press the cursor keys to move the cursor to the part of the data which is to be accessed.
- (3) Press the F1 (LAST X) key to set it to LOAD.
The data which was input last now appears.

[IN] 00:00:02:16

□ **Accessing all the data which was edited last**

- (1) Press the F2 (LAST ED) key to set it to LOAD.
All the data which was edited last now appears.

□ Variable memory function

1. Set the F3 (W/PLYR) key to OFF.

W/PLYR
OFF

2. Set the F4 (VAR MEMO) key to ON.

VAR MEMO
ON

- If the IN and OUT points have already been registered, these are automatically cleared.
 - The mode is forcibly set to OFF when the split mode is ON.
 - The AUDIO IN and OUT points cannot be registered when the variable memory function is used.
3. Input the unit's edit IN point.
This serves as the variable memory playback start point.
 - There is no need to set the OUT point with variable memory playback.
 4. Set the initial speed using the search dial.
The initial speed is displayed on the search indicator.
 5. Press the PREROLL and EXECUTE buttons together to start the operation. The tape travels as far as the preroll point, and playback is commenced at the initial speed.
 6. When the edit IN point is passed, the EXECUTE button starts flashing.
 7. Turn the search dial and store the tape speed in the memory.
 - Storing operation data in the memory is possible while the EXECUTE button is flashing. When the memory is full, the EXECUTE button stops flashing and lights up, signifying that no more operation data can be stored in the memory.
 - To change the initial speed or the setting stored in the memory, repeat the procedure starting with step 4.
 8. To end the variable memory operation, press the STOP button.
 9. To reproduce the operation stored in the memory, press the EXECUTE button.
- The tape is played back using the operation data stored in the memory starting from the point where the IN point has just been passed, and it continues traveling at the last speed which was set in the memory until the STOP button is pressed.
 - The data stored in the memory is cleared when the F4 (VAR MEMO) button is set from OFF to ON. It is also cleared when the power switch is set to OFF.

Variable memory editing

This function enables the playback speed and direction as dictated by the operation of the search dial, which is on the VTR connected to the unit's RS-422A REMOTE OUT or REMOTE IN/OUT connector, to be stored in the memory, and this operation to be reproduced for automatic editing and stored in the unit's (recorder's) memory.

1. Set the F3 (W/PLYR) key to ON.

W/PLYR
ON

- To operate the VTR connected to the unit's REMOTE OUT connector by remote control, set F5 (PLYR SEL) on the ASSEMBLE/INSERT AUTO EDIT menu to PLAY-1.
- To operate the VTR connected to the unit's REMOTE IN/OUT connector by remote control, set F5 (PLYR SEL) on the ASSEMBLE/INSERT AUTO EDIT menu to PLAY-2.

2. Set the F4 (VAR MEMO) key to ON.

VAR MEMO
ON

3. Register the recorder's VIDEO IN and OUT points and the player's IN point.
4. Select the player using the F6 (R/P SEL) key, and set the initial speed using the search dial. The initial speed is displayed on the search indicator.
5. Press the PREVIEW button. The tape travels as far as the preroll point, and playback is commenced at the initial speed.
6. When the edit IN point is passed, the EXECUTE button starts flashing.
7. Store the speed of the tape as far as the recorder's OUT point in the memory by turning the player's search dial.
Storing the speed in the memory is possible while the EXECUTE button is flashing as far as the recorder's OUT point. When the memory is full, the EXECUTE button stops flashing and lights up, signifying that no more operation data can be stored in the memory.
8. To preview what is stored in the memory, press the PREVIEW button and the operation stored in the memory is reproduced. Phase synchronization is not performed. To adjust the edit timing, use the F7 (REACTION) key on the ASSEMBLE/INSERT AUTO EDIT SET UP menu.
9. To change the operation data stored in the memory while preview is underway, operate the search dial. The EXECUTE button now flashes and the operation now underway is stored in the memory.
10. To change the initial speed stored in the memory, press the STOP button.
Set the F6 (R/P SEL) key to "PLAYER" and set the initial speed using the search dial while holding down the STOP button. Since what was stored in the memory is cleared when the initial speed has been changed, repeat the procedure starting with step 5.
11. Press the REC/EDIT button for variable memory automatic editing. The tape in the player is played back in accordance with the operation data in the memory, and the signals are recorded on the unit (recorder).
12. To review, press the REC/EDIT button and then press the REVIEW button upon completion of the editing.
 - The operation data stored in the memory is cleared when the F10 (VAR MEMO) button is set from OFF to ON.
 - It is also cleared when the power switch is set to OFF.

INSERT/ASSEMBLE AUTO EDIT SET UP menu

This menu appears when the **ASSEMBLE** or **INSERT** key and then the **F8** key are pressed.

The screenshot shows the 'AUTO EDIT : SET UP' menu with the following elements:

- Top Bar:** LTR 00:00:00:00
- Left Panel:** A vertical scale from 0 to -40 with horizontal bars representing signal levels. Below it are buttons for INT and LINE.
- Center Panel:**
 - SOFTWARE:** VIDE0, CH1, CH2, CH3, CH4, CUE, TC
 - HOME:** FREE, NRML REC, ALL
 - CASSETTE:** FREE, VID/CNTL, ALL
 - VID IN:** DIG
 - TRACKING:** A horizontal bar with a triangle and the word 'STILL'.
 - TIMING:** V PREV, A PREV, PLR SYNC, PREROLL, POSTROLL, REACTION
- Right Panel:**
 - MODE:** XFACE, FD TIME (5 mS)
 - TRACKING:** OPT. ONCE, DLY STRT (0 FR)
 - EXIT:** EXIT
- Function Keys:** F1 through F13 are arranged around the menu.

Function keys

| Key | Item | Function |
|-----|--|--|
| F1 | TIMING Edit timing setting (This function can be selected by pressing the F and F1 keys together.) | The timing can be set on the ASSEMBLE/INSERT AUTO (or MANUAL) SET UP menu (page 101). Bear in mind that if the settings are at variance, the last setting has precedence. |
| F2 | V PREV Video preview | This selects the video signal for the duration (between the IN and OUT points) of the preview operation. VVV : The video input signal is monitored. VBV : The black signal is monitored. |
| F3 | A PREV Audio preview | This selects the audio signal for the duration (between the IN and OUT points) of the preview operation. SSS : The audio input signal is monitored. SMS : The mute sound is monitored. |
| F4 | PLYR-SYNC Player sync | Selects whether to activate the synchronization function with VTR-to-VTR editing and to set the editing accuracy to ± 0 (when TC is selected). ON : The synchronization function is activated, and the editing accuracy is set to ± 0 (when TC is selected). However, for editing in the CF mode, the player's IN point is forcibly incremented by 1 when CF does not match. OFF : The synchronization function is not activated. |
| F5 | PREROLL Preroll time selection | This sets the preroll time in second increments. Any time from 0 to 30 seconds can be selected. |
| F6 | POSTROLL Postroll time selection | This sets the postroll time in second increments. Any time from 0 to 30 seconds can be selected. |
| F7 | REACTION Time compensation by time lag | This compensates the reaction time after a function button has been pressed until the actual operation. This time can be compensated in 1-frame increments from 0 to 30 frames. ●When the edit points have been set using the ENTRY IN or ENTRY OUT buttons, the value produced by subtracting the reaction time from the instant when the button was pressed serves as the edit point. Operation 1. Press the F7 (REACTION) key. 2. Adjust the time using the ADJUST control. 3. Press the F7 key. |
| F8 | EXIT | Operation is returned to the INSERT/ASSEMBLE AUTO EDIT menu. |
| F9 | DLY STRT Playback start delay | This sets in frame increments the delay time taken after the playback command has been issued until the actual operation. The time can be set in 1-frame increments up to ± 30 frames. (A "-" value reduces the delay time; a "+" value increases the delay time.) |

| Key | Item | Function |
|-----|------------------------------------|--|
| F10 | TRACKING Tracking adjustment | <p>Normally, the tracking need not be adjusted. This function is used to adjust the tracking during editing when it has shifted out of alignment.</p> <p>VAR: For adjusting the tracking manually. Refer to "Adjusting the tracking manually" (page 105).</p> <p>FIX: For fixing the tracking.</p> <p>OPT ONCE: For optimizing the tracking during playback up to the IN point with initial editing after the cassette has been inserted. Optimizing is not subsequently performed. Optimizing can also be repeated. Refer to "Adjusting (optimizing) the tracking automatically" (page 104).</p> <p>OPT AUTO: For optimizing the tracking during playback up to the IN point with each editing operation. Refer to "Adjusting (optimizing) the tracking automatically".</p> |
| F11 | — | |
| F12 | FD TIME Audio fade time setting | <p>This function is valid when the F13 key is set to X FADE or V FADE. The time can be set to 5, 10, 15, 20, 25, 50 or 100 ms (default setting: 5 ms).</p> <p>For details on the setting, refer to the section on setting the audio fade time (page 106).</p> |
| F13 | MODE Audio fade editing setting | <p>This enables audio signals to be edited while cross-fading or V-fading the preceding playback sound and input sound.</p> <p>X FADE: For audio cross-fade editing.</p> <p>CUT: The cut edit mode (normal editing) is established.</p> <p>V FADE: For audio V fade editing.</p> <p>• If audio mixing recording has been selected [F6 (CH-MIX) key on the AUDIO IN SET UP menu], cut editing will occur automatically, even if X FADE or V FADE have been selected.</p> |

Functions

Selecting the preroll time

- (1) Press the F5 (PREROLL) key.
- (2) Set the time using the ADJUST control.
Any time up to 30 seconds can be selected.

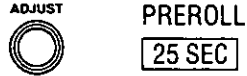

- (3) Press the F5 key.

- If the setting differs from the preroll time setting on the HOME SET UP menu, the preroll time selected last has precedence.

DLY STRT setting

- (1) Press the F9 (DLY STRT) key.
- (2) Set the time using the ADJUST control.
- (3) Press the F9 key.

- This setting is made when synchronizing VTRs whose start-up timings differ.
- When this unit is used as the deck-to-deck master machine (recorder), the delay time can be adjusted in the "+" or "-" direction. However, when it is used in the remote control mode (when a remote controller is connected to it or the unit is used as the player in a deck-to-deck configuration), the delay time can be adjusted in the "+" direction only (to increase the delay).

EDIT REC INHIBIT setting

Same as for the INSERT/ASSEMBLE MANUAL EDIT SET UP menu on page 103.

SET UP menu

This menu appears when the **SET UP** key is pressed.

The screenshot shows a control panel interface with the following elements:

- Top Left:** A vertical scale from 0 to -40 with four small icons at the top.
- Top Center:** The text "<< SET UP >>" and "LTCR 00:00:00:00".
- Top Right:** A vertical stack of buttons labeled F13, F12, F11, F10, and F9.
- Center:** A large display area showing:
 - 0 1080
 - 4 HD 59
 - 8
 - 12 1080 59
 - 16 CH0
 - 20 COMPST
 - 25 SQUEEZE
 - 30
 - 40
 - ∞
- Bottom Center:** A row of buttons labeled F1, F2, F3, F4, F5, F6, F7, and F8.
- Bottom Right:** A vertical stack of buttons labeled USER, PANEL, INTER-FACE, and another unlabeled button.
- Bottom Left:** A row of buttons labeled LR, LP, LR, LR, LR, and LINE.
- Bottom Center (Right of F1-F8):** A row of buttons labeled HOME, MAN EDIT, AUTO EDIT, SYSTEM, DOWN CONV, AUDIO IN, and AUDIO OUT.
- Bottom Left (Right of LR-LINE):** A row of buttons labeled VID IN and DIG.
- Center (Right of Scale):** A box containing the text "STILL" and a small icon.

Function keys

| Key | Item | Function |
|-------|-----------|--|
| F1 | HOME | Operation is transferred to the HOME SET UP menu. |
| F2 | MAN EDIT | Operation is transferred to the ASSEMBLE/INSERT MANUAL EDIT SET UP menu. |
| F3 | AUTO EDIT | Operation is transferred to the ASSEMBLE/INSERT AUTO EDIT SET UP menu. |
| F4 | SYSTEM | Operation is transferred to the SET UP SYSTEM menu. |
| F5 | DOWN CONV | Operation is transferred to the VIDEO OUT/DOWN CONV SET UP menu. |
| F6 | AUDIO IN | Operation is transferred to the AUDIO IN SET UP menu. |
| F7 | AUDIO OUT | Operation is transferred to the AUDIO OUT SET UP menu. |
| F8-F9 | — | |
| F10 | INTERFACE | Operation is transferred to the INTERFACE SET UP menu. |
| F11 | PANEL | Operation is transferred to the PANEL SET UP menu. |
| F12 | USER | Operation is transferred to the USER SET UP menu. |
| F13 | — | |

INTERFACE SET UP menu

This menu appears when the **SETUP** key and then the **F10** key are pressed.

<< INTERFACE : SET UP >>
DEVICE ID : F030
LTCR 00:00:00:00

MODE-1

CH ASSIGN

| | | | | | |
|---------|------|------|------|------|-----|
| AUDIO-1 | CH-1 | CH-2 | CH-3 | CH-4 | CUE |
| AUDIO-2 | CH-1 | CH-2 | CH-3 | CH-4 | CUE |

V/A CONTROL

BAUD RATE : 1200

| | |
|----------|-------|
| VAR LIMT | OFF |
| UB PREST | L & V |
| EXIT | |

| | | | | | | |
|--------|---------|------|----------|--------|---------|---------|
| P-2 | RS-232C | PARA | AV CONT. | FF/REW | MAX SP. | DEV. ID |
| MODE-1 | OFF | OFF | ON | 50 | DEFAULT | |

F13

F12

F11

F10

F9

F1

F2

F3

F4

F5

F6

F7

F8

Function keys

| Key | Item | Function |
|---------|---|--|
| F1 | P-2 RS-422A control mode setting | When operating by remote control a component connected to the RS-422A REMOTE connector, four modes can be selected depending on the system configuration. The flow of the signals in each mode appears on the menu. Refer to the "Mode and connector correspondence table" on page 121. MODE-1: The VTR(s) connected to the REMOTE OUT and/or REMOTE IN/OUT connectors can be controlled. MODE-2: Two or more VTRs are controlled in the same mode as this unit. MODE-3: The VTR connected to the REMOTE OUT connector can be controlled. MODE-4: Two or more VTRs can be controlled in the same mode as this unit. OFF: No RS-422A control. |
| F2 | RS-232C Parameter setting | ON: Parameters can be set and controlled. Refer to the section on setting the RS-232C parameters on page 137. OFF: Parameters cannot be set and controlled. |
| F3 | PARA 50P parallel remote ON/OFF | ON: Control is enabled. OFF: Control is disabled. |
| F4 | AV CONT. V/A control | ON: Control from the V/A control is accepted. OFF: Control from the V/A control is prohibited. |
| F5 | FF/REW MAX SP. Maximum FF/REW speed setting | This switches the FF/REW tape speed to 50× or 32× normal speed. |
| F6 | DEV ID Device type (This function can be selected by pressing the C, F and F6 keys together.) | This selects the device ID to be returned to the controller via the RS-422A connection. There are 4 device IDs in addition to the default value: ID-1, ID-2, ID-3 and USER. Select an ID which will match the controller used. To change the USER setting device ID, consult with a servicing representative. |
| F7 | — | |
| F8 | EXIT | Operation is returned to the SET UP menu. |
| F9 | UB PRESET UB setting from remote command | L&V: The user bit is recorded on the LTC and VITC. LTC: The user bit is recorded on the LTC. VITC: The user bit is recorded on the VITC. |
| F10 | VAR LIMT (This function can be selected by pressing the F and F10 keys together.) | ON: The maximum speed in the VAR operation mode controlled by the remote command is limited to 2× normal tape speed. OFF: The maximum speed in the VAR operation mode controlled by the remote command is limited to 2.5× normal tape speed. |
| F11–F13 | — | |

Functions

□ Mode and connector correspondence table

| MODE | Connection (remote) when the unit is operated by remote control as a source machine from an editor or when editing is performed using a controller | | | Connection (local) when editing is performed by operating the controls on the unit's front panel | | |
|--------|--|----------|------------|--|----------|----------|
| | IN | OUT | IN/OUT | IN | OUT | IN/OUT |
| MODE-1 | Controller | Player 1 | No | No | Player 1 | No |
| MODE-1 | Controller | Player 1 | No | No | No | Player 2 |
| MODE-2 | Controller | Player 1 | No | No | No | No |
| MODE-3 | No | Player 1 | Controller | No | Player 1 | No |
| MODE-3 | No | Player 1 | Controller | No | No | Player 2 |
| MODE-4 | No | Player 1 | Controller | No | No | No |

MODE-1 connection diagram

← Command
 ← Return data

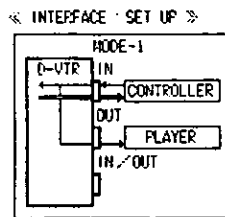

MODE-2 connection diagram

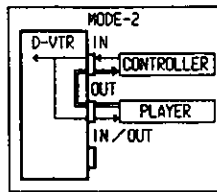

MODE-3 connection diagram

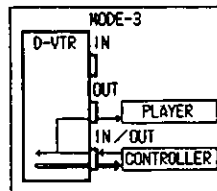

MODE-4 connection diagram

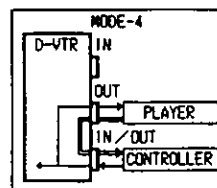

□ **Setting the RS-232C parameters**

| | |
|---------------|------|
| RS-232C | |
| BAUD RATE : | 9600 |
| DATA LENGTH : | 8 |
| START BIT : | 1 |
| STOP BIT : | 1 |
| PARITY : | ODD |

- (1) Press the F2 (RS-232C) key to set it to ON.
The parameter display appears.

BAUD RATE: 300, 600, 1200, 2400, 4800 or 9600
DATA LENGTH: 7 or 8 bits
START BIT: Fixed at 1 bit
STOP BIT: 2 bits or 1 bit
PARITY: NONE, ODD or EVEN

- (2) Press the cursor center key.
The input area flashes.
- (3) Press the cursor keys to select the input area.
When the F and cursor keys are pressed together, the cursor moves to another block.

BAUD RATE:

- (4) Press the cursor center key to set the parameter.

BAUD RATE:

- (5) Press the ENT key to enter the setting.

□ **Setting the V/A control parameter**

Any of the following baud rates can be selected for the V/A control parameter.

| |
|---------------------------------------|
| BAUD RATE: 300, 600, 1200, 2400, 4800 |
|---------------------------------------|

- (1) Press the cursor center key.
The input area now starts flashing.
- (2) Press the F key and cursor keys together to move the cursor to the V/A CONTROL block.

| |
|----------------|
| V/A CONTROL |
| BAUD RATE: 300 |

- (3) Press the cursor center key to set the parameter.

| |
|-----------------|
| V/A CONTROL |
| BAUD RATE: 4800 |

- (4) Press the ENT key to enter the setting.

□ Setting the CH ASSIGN audio channel

The commands from the controller which has only the analog audio CH1 and CH2 preset commands are reread and allocated to digital audio channels CH1–CH4 and to the cue channel.

- (1) Press the cursor center key to display the cursor.
The input area flashes.

- (2) Press the F and cursor keys together to move the cursor to the CH ASSIGN block.

AUDIO-1
 AUDIO-2

- (3) Press the cursor keys to move the cursor to the channel selection position.

AUDIO-1
 AUDIO-2

- (4) Press the cursor center key to turn the display ON or OFF. At ON, the display is highlighted.

AUDIO-1
 AUDIO-2

- (5) Press the ENT key to enter the setting.

PANEL SET UP menu

This menu appears when the **SET UP** key and then the **F11** key are pressed.

<< PANEL : SET UP >>
LTCR 00:00:00:00

| | | | | | | | |
|-----|---|---|---|---|-----|---------|--|
| 0 | - | - | - | - | 0 | 1080 | VAR CLUTCH OFF MAX SP. -1+++2 REMOTE OP MAP LOCAL OP MAP EXIT |
| -4 | - | - | - | - | -4 | REF | |
| -8 | - | - | - | - | -8 | HD 59 | |
| -12 | - | - | - | - | -12 | REF | |
| -16 | - | - | - | - | -16 | 1080 59 | |
| -20 | ◀ | ◀ | ◀ | ◀ | -20 | REF | |
| -25 | - | - | - | - | -25 | CH8 | |
| -30 | - | - | - | - | -30 | TO PULL | |
| -40 | - | - | - | - | -40 | CMPST | |
| -∞ | - | - | - | - | -∞ | REF | |
| | | | | | | SQUEEZE | |

LR

LP

LR

LR

LR

VID IN

SOUND

JOG

SHTL

- STILL +

AES

AES

AES

AES

LINE

DIG

KEY

ALARM

MAX SP.

L/C/R

X 8.X 4

MAX SP.

A SCALE

OFF

OFF

-1+++2

ON

OFF

50

-18 dB

F1

F2

F3

F4

F5

F6

F7

F8

F13

F12

F11

F10

F9

Function keys

| Key | Item | Function |
|-----|--|---|
| F1 | SOUND KEY Click sound selection for function key and IN/OUT key | OFF: No click sound HIGH: Loud click sound LOW: Soft click sound |
| F2 | SOUND ALARM Selection of alarm beep when error occurs | OFF: No alarm beep HIGH: Loud alarm beep LOW: Soft alarm beep |
| F3 | JOG MAX SP Maximum jog speed setting | -2↔+2: -2× to +2× normal speed range (when a tape recorded in a D-5 machine is played back) -1↔+1: -1× to +1× normal speed range -1↔+2: -1× to +2× normal speed range |
| F4 | SHTL L/C/R Shuttle dial clutch ON/OFF | OFF: No clutch (F5 key is also set to OFF). ON: Clutch is set to 3 points (far left, center and far right). |
| F5 | SHTL ×8, ×4 Shuttle dial 8×/4× clutch selection | OFF: No clutch ×8: Clutch is set to the ±8× normal speed position. ×8, ×4: Clutch is set to four positions: ±4× and ±8× normal speed. ×4: Clutch is set to the ±4× normal speed position. |
| F6 | SHTL MAX SP Maximum shuttle speed selection | The maximum shuttle speed can be set to 50×, 32× or 16× normal tape speed. |
| F7 | A SCALE Level meter scale setting | -20 dB: The reference level is set to -20 dB. 0 dB: The reference level is set to 0 dB. |
| F8 | EXIT | Operation is returned to the SET UP menu. |
| F9 | — | |
| F10 | LOCAL OP MAP | Operation is transferred to the LOCAL OP MAP. |
| F11 | REMOTE OP MAP | Operation is transferred to the REMOTE OP MAP. |
| F12 | VAR MAX SP Maximum variable speed selection | -1↔+2: -1× to +2× normal speed range -1↔+1: -1× to +1× normal speed range 0↔+1: 0× to +1× normal speed range |
| F13 | VAR CLUTCH Dial clutch ON/OFF in variable mode | OFF: No clutch ON: Clutch is set to -1×, 0×, +1× or +2× normal speed position. |

PANEL SET UP (REMOTE OP MAP) menu

This menu appears when the **SETUP** key, then the **F11** key and finally the **F11** key are pressed.

The buttons, keys and controls which can be operated on the unit's front panel in the remote control mode are set and displayed on this menu.

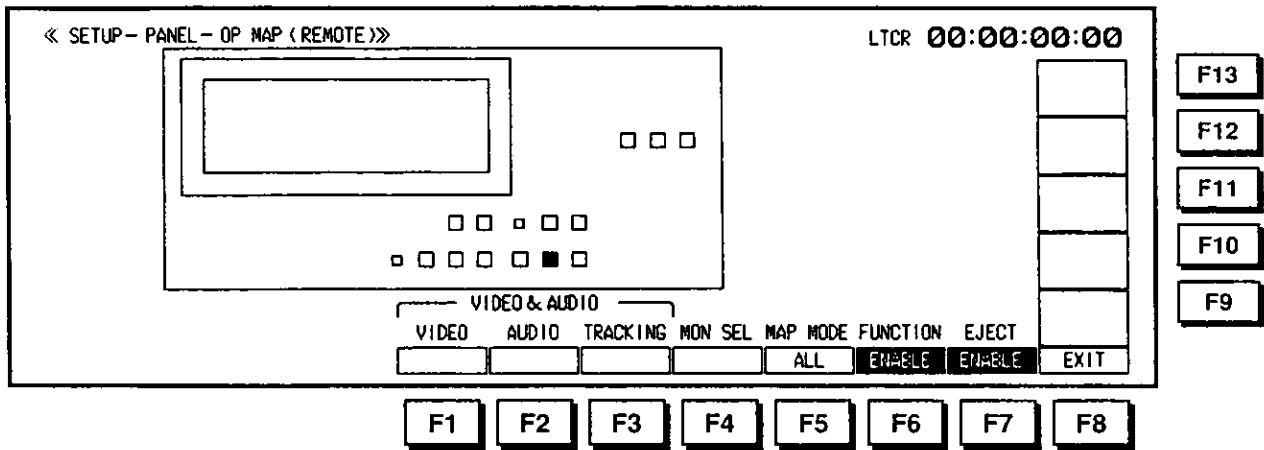

Function keys

| Key | Item | Function |
|--------|--|--|
| F1 | VIDEO Video level adjustment | This selects the level adjustment function on the VIDEO OUT menu. When the key is pressed, its display is highlighted. |
| F2 | AUDIO Audio level adjustment | This selects the audio signal recording and playback level adjustment function. When the key is pressed, its display is highlighted. |
| F3 | TRACKING Tracking adjustment | This selects the tracking adjustment. When the key is pressed, its display is highlighted. |
| F4 | MON SEL Monitor selection | This selects the monitor selection L/R buttons for the audio signals. When the key is pressed, its display is highlighted. |
| F5 | MAP MODE Key operation enable | ALL: All keys can be operated by remote control. SELECT: The selected keys can be operated by remote control. |
| F6 | FUNCTION Entire function enable/disable | ENABLE: Entire function is enabled. DISABLE: Entire function is disabled. |
| F7 | EJECT Enable/disable setting of EJECT button in remote control mode | ENABLE: The eject button can be operated. DISABLE: The eject button cannot be operated. |
| F8 | EXIT | Operation is returned to the SET UP menu. |
| F9-F13 | — | |

Functions

□ F5 (MAP MODE)/F6 (FUNCTION) key combined settings

| F5 (MAP MODE) | F6 (FUNCTION) | Description of setting | |
|---------------|---------------|--|--|
| | | Operation keys (STOP, PLAY, etc.) | Function keys (F1–F13, controls, etc.) |
| ALL | ENABLE | All the keys can be operated regardless of the setting on this menu. | All the keys can be operated regardless of the setting on this menu. |
| | DISABLE | Operation of all the keys is inhibited regardless of the setting on this menu. | Functions other than those selected by the F1 to F4 keys on this menu are inhibited. |
| SELECT | ENABLE | Only the keys selected on this menu can be operated. | Only the functions selected by the F1 to F4 keys on this menu and other specifically designated functions can be operated. |
| | DISABLE | Operation of all the keys is inhibited regardless of the setting on this menu. | Same as above |

Notes:

- Even if it has been set to ENABLE on this menu, the F6 key setting is changed to DISABLE when the unit receives the LOCAL DISABLE command in the remote control mode. [The EJECT button behaves in compliance with the F7 (EJECT) key setting.]
- At the factory the F6 key is set to ENABLE and the F5 key to SELECT.

□ OP MAP setting method

- The buttons and keys marked on the control panel graphics on the display correspond to the buttons and keys on the actual control panel. The area corresponding to a key or button which has been pressed on the control panel is highlighted on the display.
- The search dial is displayed when the JOG, VAR or SHTL button is pressed.
- The ADJUST control is displayed when the F1 (VIDEO) key is pressed.
- The audio adjustment VRs are displayed when the F2 (AUDIO) key is pressed.
- The ADJUST control is displayed when the F3 (TRACKING) key is pressed.
- The L/R buttons are displayed when the F4 (MON SEL) key is pressed.

PANEL SET UP (LOCAL OP MAP) menu

This menu appears when the **SET UP** key, then the **F11** key and finally the **F10** key are pressed.

The buttons, keys and controls whose operation is to be disabled on the unit's front panel in the local mode are set and displayed on this menu.

This facility prevents any changes made in the settings or adjustment values due to careless handling.

- The default setting is that all the keys can be operated.

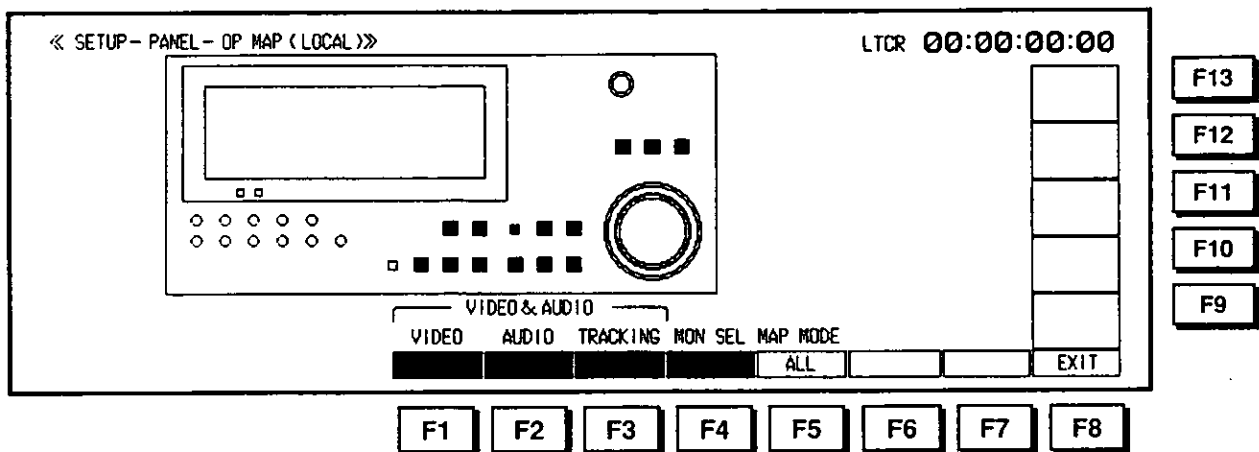

Function keys

| Key | Item | Function |
|--------|----------------------------------|--|
| F1 | VIDEO Video level adjustment | This selects the level adjustment function on the VIDEO OUT menu. When the key is pressed, its display is highlighted. |
| F2 | AUDIO Audio level adjustment | This selects the audio signal recording and playback level adjustment function. When the key is pressed, its display is highlighted. |
| F3 | TRACKING Tracking adjustment | This selects the tracking adjustment. When the key is pressed, its display is highlighted. |
| F4 | MON SEL Monitor selection | This selects the monitor selection L/R buttons for the audio signals. When the key is pressed, its display is highlighted. |
| F5 | MAP MODE Key operation enable | ALL: All keys can be operated regardless of the OP MAP setting. SELECT: Only the functions set by OP MAP can be operated. |
| F6–F7 | — | |
| F8 | EXIT | Operation is returned to the SET UP menu. |
| F9–F13 | — | |

OP MAP setting method

- The buttons and keys marked on the control panel graphics on the display correspond to the buttons and keys on the actual control panel.
The area corresponding to a key or button which has been pressed on the control panel is highlighted on the display.
- The search dial is displayed when the JOG, VAR or SHTL button is pressed.
- The ADJUST control is displayed when the F1 (VIDEO) key is pressed.
- The audio adjustment VRs are displayed when the F2 (AUDIO) key is pressed.
- The ADJUST control is displayed when the F3 (TRACKING) key is pressed.
- All the keys can be operated at the time when the unit was shipped since the F5 (MAP MODE) key was set to ALL at the factory.

USER SET UP menu

This menu appears when the **SET UP** key and then the **F12** key are pressed.

<< USER : SET UP >>
LTCR 00:05:53:04

| FILE NAME | PASS WORD | FILE NAME | LOCK |
|-----------|-----------|---------------|--------------------------|
| LAST | | 5 S.Y | <input type="checkbox"/> |
| FACTORY | | 6 6 | <input type="checkbox"/> |
| 1 | ⓐ | 7 | <input type="checkbox"/> |
| 2 | ⓐ | 8 | <input type="checkbox"/> |
| 3 | ⓐ | 9 | <input type="checkbox"/> |
| 4 | ⓐ | 10 AAAAAAAAAA | <input type="checkbox"/> |

ABCDEFGHIJ
 KLMNOPQRST
 UVWXYZ 012
 3456789<=>
 ? : + - () . _

STILL
 M

PASS-WORD
 LOCK
 EXIT

LOAD
FILE SAVE
DELETE
POWER UP

F1

F2

F3

F4

F5

F6

F7

F8

F13

F12

F11

F10

F9

Function keys

| Key | Item | Function |
|---------|--|---|
| F1 | LOAD File loading | When this key and the F key are pressed together, the selected file is loaded. |
| F2 | SAVE File saving | When this key and the F key are pressed together, the selected file is saved. |
| F3 | DELETE File deletion | When this key and the F key are pressed together, the selected file is deleted. |
| F4 | — | |
| F5 | POWER UP File loading when power is turned on | LAST: The last file is loaded. FACTORY: The factory file is loaded. 1-10: The user file is loaded. |
| F6-F7 | — | |
| F8 | EXIT | Operation is returned to the SET UP menu. |
| F9 | LOCK File locking | This key is pressed together with the F key. The selected file is locked to disable updating or deletion. The lock is released when the key is pressed again. This function is used for user files 5 to 10. |
| F10 | PASSWORD | This is pressed to set the password. |
| F11-F13 | — | |

Functions

□ Saving user files

Twelve files are provided with this unit.

Two of these files are reserved: the LAST file containing the statuses applying when the power was last switched off, and the FACTORY file containing the statuses established at the factory (default settings). These two files cannot be deleted or updated.

The remaining 10 files are user files. The user can use them to enter any menu settings which can then be loaded, deleted or updated at the user's preference.

- (1) Establish the status in which the menu settings are to be entered. Refer to the table at the end of these instructions for what is saved on the files.
 - Where a UNITY or VAR setting is involved, the VAR value will nevertheless be saved even if UNITY has been selected.
- (2) Press the cursor keys to select the number of the file to be entered. The cursor first appears where it was previously assigned.

| | | |
|---|---------|---|
| | FACTORY | |
| 1 | | * |
| 2 | | * |
| 3 | | * |
| 4 | | * |

- (3) Input the file name. Up to 20 characters can be input.
 1. EDITOR 1
- (4) Press the F and F2 (SAVE) keys together to save the file.

File name input

| | | | | | | | | | | |
|---|---|---|---|---|---|---|---|---|---|---|
| 4 | B | C | D | E | F | G | H | I | J | |
| | K | L | M | N | O | P | Q | R | S | T |
| | U | V | W | X | Y | Z | 0 | 1 | 2 | |
| | 3 | 4 | 5 | 6 | 7 | 8 | 9 | < | = | > |
| | ? | : | + | * | - | (|) | . | _ | |

- Numbers 0 to 9: Press the corresponding number keys.
- Proceed as below to enter letters of the alphabet.
 - 1) Press the cursor center key.
 - 2) Move the cipher cursor to the left or right using the ADJUST control to select the desired character.

When the F and cursor keys are pressed together, the cursor can be moved up or down as well as to the left or right.
 - 3) Press the ENT key to input the character under the cursor.
 - 4) Press the cursor center key to complete the character input.
- To correct a character, press the BS key. To proceed with input again from the beginning, press the C key.

The password is required to enter files 1 to 4.

- (1) Press the F10 (PASSWORD) key.
- (2) Input the 4-character password.
 - Discuss the choice of a password with the servicing engineer.

Locking user files

In this mode, files are protected and can no longer be deleted or updated.

(1) Press the cursor keys to select the file to be locked.

1. EDITOR 1

(2) Input the password for files 1 to 4.

Press the F and F9 keys together for files 5 to 10.

When a file is locked, it is highlighted on the display.

1. EDITOR 1

● To release the file lock function

The lock on files 1 to 4 is released when the password is entered.

1. Press the cursor keys to select the file whose lock is to be released.

2. Press the F10 (PASSWORD) key.

3. Input the 4-character password.

If the password input is correct, the lock is released; if it is incorrect, the lock is not released.

The lock on files 5 to 10 is released when the F and F9 keys are pressed together again.

1. EDITOR 1

Updating user files

(1) Press the cursor keys to select the file to be updated.

● If the file is locked, release the lock.

1. EDITOR 1

↑ Lock released
(if this is highlighted,
release the lock)

(2) Change the contents of the files.

For instance, press the F4 (TC/CTL) key on the HOME menu to change the setting from TC to CTL1.

(3) Press the F and F2 (SAVE) keys together.

The file with the revised contents will be saved.

The F4 (TC/CTL) key setting is changed to CTL1 when the F and F1 (LOAD) keys are pressed together and then the HOME button is pressed to enter the HOME menu.

● The contents prior to the change are deleted.

Deleting user files

This function deletes unnecessary files.

- (1) Press the cursor keys to select the file to be deleted.

5. EDITOR 2

(File locked)

- (2) Check that the lock on the file to be deleted has been released. If it is still locked, refer to "Locking user files" to release it.

5. EDITOR 2

(Lock released)

- (3) Press the F and F3 (DELETE) keys together.
The file is deleted.

- The file cannot be deleted unless the file lock is released first.

 Loading user files

This function loads a saved file.

- (1) Press the cursor keys to select the file to be loaded.

1. EDITOR 1

- (2) When the F and F1 (LOAD) keys are pressed together, the selected file is loaded.
Check the file which has been loaded.

 Automatically loading a file when the power is turned on

This function automatically loads a file when the power is turned on.

- (1) Press the F5 (POWER UP) key.
A file is loaded each time this key is pressed.

The selected file is loaded automatically when the power is next turned on.

- The default setting is the LAST file.

Copying filenames

When the same filename is to be given, that filename is copied.

(1) Press the cursor keys to select the filename to be copied.

1. EDITOR 1

(2) Press the FROM (F+2) key.

1. EDITOR 1

(3) Press the cursor keys to select the copy destination file number.

5.

(4) Press the COPY (F+1) key.
The filename is now copied.

5. EDITOR 1

• This function merely serves to copy filenames.

Note that the contents of the files are not copied.

After having copied a filename, proceed with the normal entry operation (SAVE: F+F2).

SET UP SYSTEM menu

This menu is displayed when the **F4** key is pressed from **SET UP**

The screenshot shows the 'SET UP SYSTEM' menu. At the top left, it says '<< SET UP : SYSTEM >>'. At the top right, it shows 'LTCR 00:00:00:00'. The main area contains several settings: 'VIDEO IN VIDEO OUT' with values '1125/720P FLD RATE ACT LINE ACT LINE DATA' and '1125 59 1080 1080 10BIT'. On the right side, there are three options: 'S VITC ON', 'S LTC ON', and 'S AUDIO ON'. Below these are 'HD SERIAL' and 'EXIT'. At the bottom, there are function keys F1 through F8. On the right side of the screen, there are additional function keys F9, F10, F11, F12, and F13.

| VIDEO IN | VIDEO OUT | FLD RATE | ACT LINE | ACT LINE | DATA | | | |
|----------|-----------|----------|----------|----------|------|--|--|------|
| 1125 | 59 | 1080 | 1080 | 10BIT | | | | EXIT |

Function keys: F1, F2, F3, F4, F5, F6, F7, F8, F9, F10, F11, F12, F13

Function keys

| Key | Item | Function |
|---------|--|---|
| F1 | 1125/720p | This is used to switch from the 1125 HDTV to the 720p HDTV system or vice versa. |
| F2 | FLD RATE Internal generator field frequency setting | The field frequency used is set when this key is pressed together with the F key. 60: The field frequency is set to 60 Hz. 59: The field frequency is set to 59 Hz. However, the FLD (field) frequency set here is used only when an input signal supporting the output reference set on the HOME SET UP menu (see page 60) is not available. When the input signals supporting the said setting are available, the field frequency matches the field frequency which has been input. |
| F3 | VIDEO IN ACT LINE | The number of active recording lines is set when this key is pressed together with the F key. 1035: The number is set to 1,035 recording lines. 1080: The number is set to 1,080 recording lines. |
| F4 | VIDEO OUT ACT LINE | The number of active output lines is set when this key is pressed together with the F key. 1035: The number is set to 1,035 output lines. 1080: The number is set to 1,080 output lines. |
| F5 | DATA | The number of output bits for the HD serial output is selected when this key is pressed together with the F key. 10BIT: 10 bits are used ofr the HD serial output. 8BIT: 8 bits are used for the HD serial output. |
| F6 | ROUND | This sets rounding for the output to ON or OFF when 8BIT is selected for the number of bits and when this key is pressed together with the F key. ON: The output is rounded. OFF: The output is not rounded. |
| F7 | — | |
| F8 | EXIT | This returns operation to the SET UP menu. |
| F9 | S AUDIO (This function can be selected by pressing the F and F9 keys together.) | ON: The audio CH1, 2, 3 and 4 signals are output to the serial V/A output. OFF: The audio CH1, 2, 3 and 4 signals are not output to the serial V/A output. |
| F10 | S LTC (This function can be selected by pressing the F and F10 keys together.) | ON: LTC is added to the serial V/A output. OFF: LTC is not added to the serial V/A output. |
| F11 | S VITC (This function can be selected by pressing the F and F11 keys together.) | ON: VITC is added to the serial V/A output. OFF: VITC is not added to the serial V/A output. |
| F12-F13 | — | |

TEST menu

This menu appears when the **TEST** key is pressed.

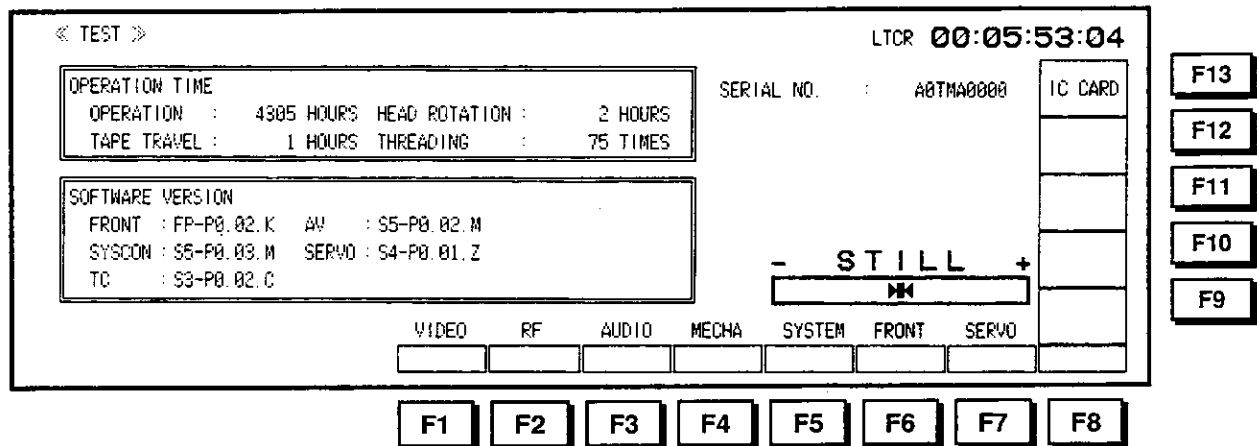

Function Keys

| Key | Item | Function |
|--------|---------|---|
| F1 | VIDEO | Operation is transferred to the VIDEO TEST menu. |
| F2 | RF | Operation is transferred to the RF TEST menu. |
| F3 | AUDIO | Operation is transferred to the AUDIO TEST menu. |
| F4 | MECHA | Operation is transferred to the MECHA TEST menu. |
| F5 | SYSTEM | Operation is transferred to the SYSTEM TEST menu. |
| F6 | FRONT | Operation is transferred to the FRONT TEST menu. |
| F7 | SERVO | Operation is transferred to the SERVO TEST menu. |
| F8-F12 | — | |
| F13 | IC CARD | Operation is transferred to the IC CARD menu. |

OPERATION TIME display

This displays the frequency of VTR use.

OPERATION: Total power-on time (cumulative)
HEAD ROTATION: Total head drum rotation time (cumulative)
TAPE TRAVEL: Total tape travel time (cumulative)
THREADING: Total number of loading/unloading repetitions (cumulative)

| | | | |
|----------------|------------|-----------------|----------|
| OPERATION TIME | | | |
| OPERATION : | 4385 HOURS | HEAD ROTATION : | 2 HOURS |
| TAPE TRAVEL : | 1 HOURS | THREADING : | 75 TIMES |

SOFTWARE VERSION

This displays the software versions.

FRONT: Front software
SYSCON: Syscon software
TC: Time code software
AV: AV control software
SERVO: Servo software

| | | | |
|------------------|------------|---------|------------|
| SOFTWARE VERSION | | | |
| FRONT : | FP-P0.02.K | AV : | S5-P0.02.M |
| SYSCON : | S5-P0.03.M | SERVO : | S4-P0.01.Z |
| TC : | S3-P0.02.C | | |

SERIAL NO. display

This displays the unit's serial number.

SERIAL NO.

VIDEO TEST menu

After the tape has been ejected, this menu appears when the **TEST** key and then the **F1** key are pressed.

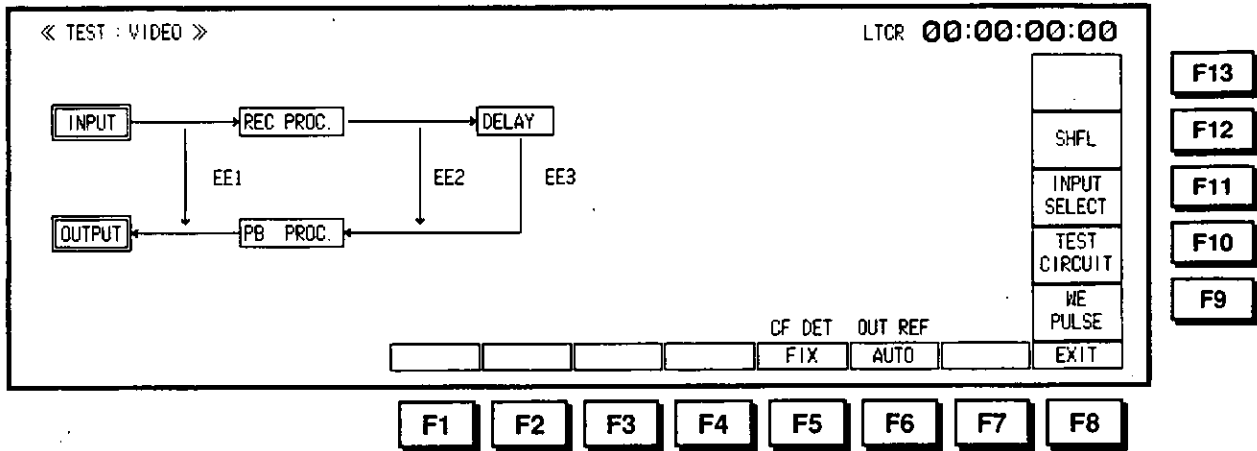

Function keys

| Key | Item | Function |
|---------------------|--|--|
| <hr/> F1-F4 <hr/> | | |
| F5 | CF DET | <p>This menu item appears when down-converter board (AJ-DFC2000, optional accessory) has been installed. When "NTSC REF" has been selected as the F6 key OUT REF setting, the detection of the color frames of the NTSC reference signal is switched.</p> <p>FIX: The color frames are detected using the phases of the burst and H sync signals complying with the SMPTE 170M standard as the reference.</p> <p>FREE: The color frames are determined artificially inside the unit without detecting the difference between the sync and burst signal phases.</p> |
| F6 | OUT REF | <p>This selects the video output reference.</p> <p>AUTO: When the HD REF input signal is provided, this serves as the reference. When it is not available, the HD serial input signal serves as the reference. When neither the HD REF nor HD serial input signal is provided, the internal sync signal serves as the reference.</p> <p>INPUT: The HD serial input signal serves as the reference.</p> <p>HD REF: The signal supplied to the HD REF VIDEO IN connector serves as the reference.</p> <p>NTSC REF: This menu item appears only when down-converter board (AJ-DFC2000) has been installed. The black burst signal supplied to the NTSC REF connector serves as the reference.</p> |
| F7 | — | |
| F8 | EXIT | Operation is returned to the TEST menu. |
| F9 | — | |
| F10 | TEST CIRCUIT Circuit test | Operation is transferred to the circuit test mode. |
| F11 | INPUT SELECT Video input signal selection | Operation is transferred to the video input signal selection mode. |
| <hr/> F12-F13 <hr/> | | |

The circuit test mode is established when the F10 (TEST CIRCUIT) key is pressed. Signal bypassing can then be set using the F1 to F3 keys.

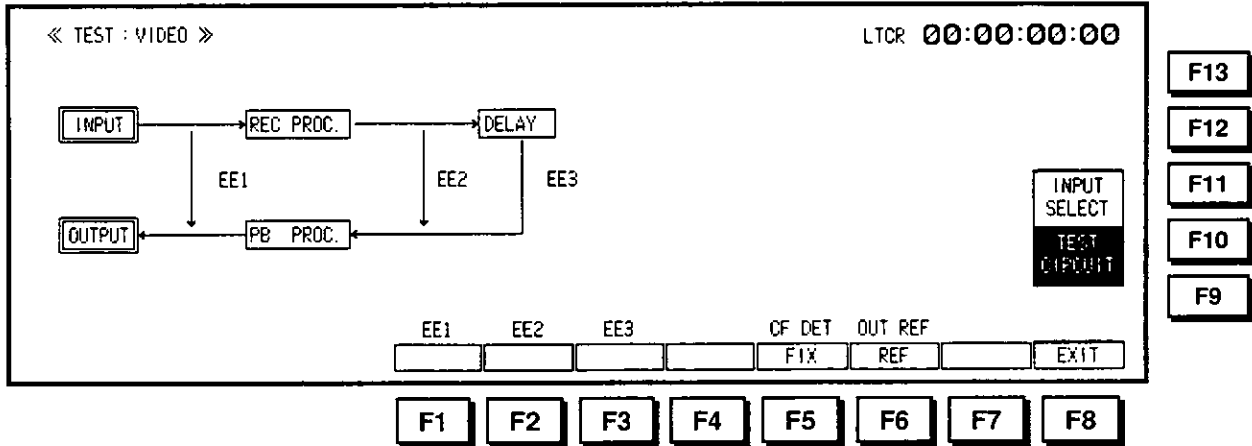

Function keys

| Key | Item | Function |
|--------|-------------------------------------|---|
| F1 | EE1 Video input signal bypass | |
| F2 | EE2 Video input signal bypass | This screen serves as a trouble monitor for the video input signals. When a key is pressed, the corresponding bypass number section is highlighted. |
| F3 | EE3 Video input signal bypass | |
| F4-F13 | — | |

The video input signal selection mode is established when the F11 (INPUT SELECT) key is pressed. The video input signals can then be selected using the F1 key.

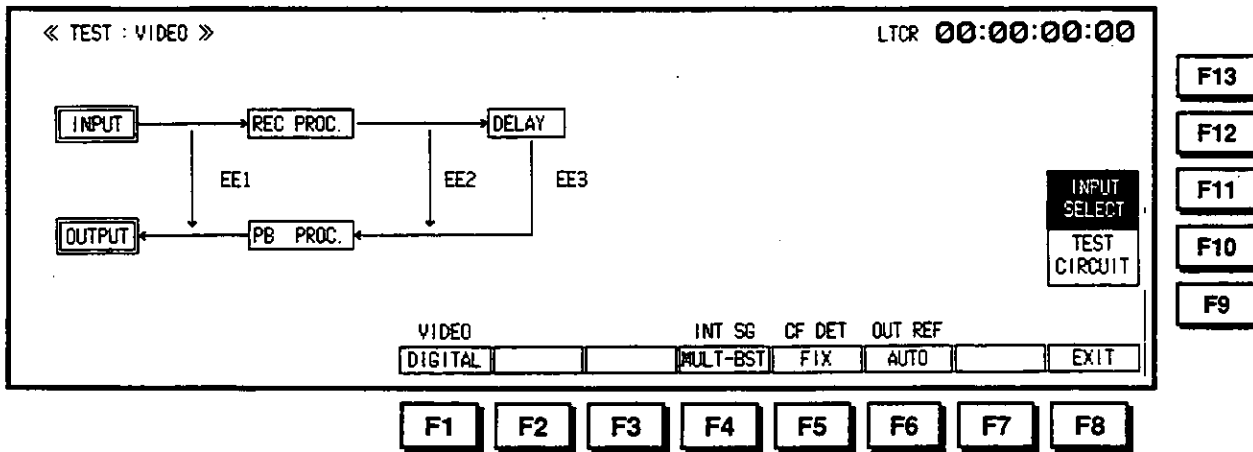

Function keys

| Key | Item | Function |
|--------|--|--|
| F1 | VIDEO Video input signal selection | DIGITAL: The input signals of the HD SERIAL INPUT connector are selected. INT SG: The input signals of the internal signal generator are selected. |
| F2-3 | — | |
| F4 | INT SG Selection of signal from internal signal generator | 100% CB: The 100% color bar signal is selected. 75% CB: The 75% color bar signal is selected. BLACK: The black burst signal is selected. MULTI-BST: The multi burst signal is selected. RAMP: The ramp signal is selected. SIF PLL: The signal for checking the serial interface PLL is selected. SIF EQ: The signal for checking the serial interface equalizer is selected. |
| F5-F13 | — | |

RF TEST menu

This menu appears when the **TEST** key and then the **F2** key are pressed.

The RF TEST menu interface includes the following elements:

- TOTAL ERROR:** Two vertical bar graphs for VIDEO and AUDIO, each with a scale from -5 to -1.
- INNER ERROR VIDEO & AUDIO:** A grid of 12 vertical bar graphs for channels A and B across CH0, CH1, CH2, and CH3.
- REC ENV:** A vertical bar graph with a scale from -5 to -1.
- LTCR:** A digital display showing 00:00:00:00.
- HEAD CLM:** A small rectangular display area.
- STILL:** A horizontal bar with a central 'M' icon and '-' and '+' markers.
- VIDEO/AUDIO:** Labels for VIDEO, AUDIO, OUTER, and CHI.
- ECC SMPL METER:** Labels for SLOW and ERROR.
- LOAD:** A small rectangular display area.
- ADJ RF:** A button.
- AT HEIGHT:** A button.
- REC CURR OPT:** A button.
- EXIT:** A button.
- MON:** A small display area.

Function keys are arranged as follows:

- Top Row:** F13, F12, F11, F10, F9
- Bottom Row:** F1, F2, F3, F4, F5, F6, F7, F8

Function keys

| Key | Item | Function |
|-------|--|--|
| F1 | ECC SMPL Error rate measuring time change | FAST: The measuring interval is 20 fields. SLOW: The measuring interval is 2 seconds. |
| F2 | METER Error rate level display switching | ERROR: The inner error level is displayed. ENV: The envelope level is displayed. |
| F3 | — | |
| F4 | LOAD Default value loading | All the RF adjustment values are returned to the factory settings. (This key functions when it is pressed together with the F key.) |
| F5–F7 | — | |
| F8 | EXIT | Operation is returned to the TEST menu. |
| F9 | REC CURR OPT Recording current optimizing | When this key is pressed, the OPT display is highlighted. When the EXECUTE button is then pressed, optimizing is executed and the recording current is optimized. |
| F10 | AT HEIGHT AT HEIGHT display | Key for adjustment by servicing engineer. |
| F11 | ADJ RF RF adjustment value display | The RF adjustment value is displayed. Refer to "RF adjustment value display" on page 150. |
| F12 | — | |
| F13 | HEAD CLN Manual head cleaning | The heads are cleaned (but only for a maximum of 20 seconds) while this key is kept depressed. Operation 1. Set the VTR to the PLAY mode. 2. Press the F13 (HEAD CLN) key. The heads are cleaned when the unit is in the PLAY, JOG or VAR mode. |

Error rate display

Two types of error rates (error occurrence rates) are displayed:

- 1) TOTAL ERROR and 2) INNER ERROR.

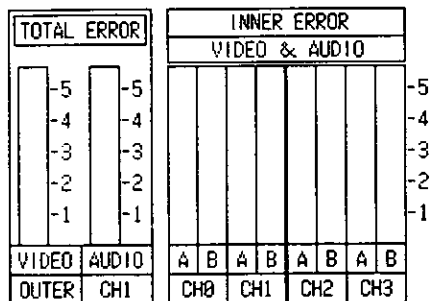

1) TOTAL ERROR

During recording, the error rate of the simultaneous playback signals is displayed; during playback, the error rate of the playback signals is displayed. To select the audio channel, press the cursor center key.

2) INNER ERROR

The error rate is displayed for 8 heads after the inner errors have been corrected. [However, the error rate prior to correction will be displayed when the inner error correction switch (SW5 on the L4 circuit board) is OFF.]

To switch between AUDIO & VIDEO and AUDIO, proceed as follows:

1. Press the cursor center key to display the cursor.
2. Press the F key and cursor key (◀ or ▶) together to move the cursor to INNER ERROR.
3. Press the cursor center key to select AUDIO & VIDEO or AUDIO.
4. Press the ENT key to enter the setting.

Recording current optimization

- (1) Press the F9 key. The OPT display is highlighted.



- (2) Press the EXECUTE key. The recording current for all channels is adjusted automatically.
 - Check that the tape used can be recorded on. Bear in mind that it takes about 5 minutes for the automatic adjustment to be completed.

Auto equalizing function

- (1) Press the F11 (ADJ RF) key to highlight the display. F6 (ADJ MODE), F7 (ADJ CH) and F12 (ADJ SEL) appear.

- (2) Press the F6 (ADJ MODE) key to select AUTO EQ.

The auto equalizing function is now activated, and when the error rate (rate at which errors occur) increases, the parameters are re-adjusted automatically and set to their optimum state.

- When AUTO EQ is selected, the modes can no longer be changed using the F keys on the TEST RF menu.
- This mode is held even when operation is transferred to another menu. To return the parameter value to the factory setting, press the F and F4 (LOAD) keys. However, this will return all the RF adjustment values including the recording current to the factory settings.
- When the F6 (ADJ MODE) key is pressed again, it returns to the FIX setting at which the auto equalizing function is not activated and the parameter values remain fixed.

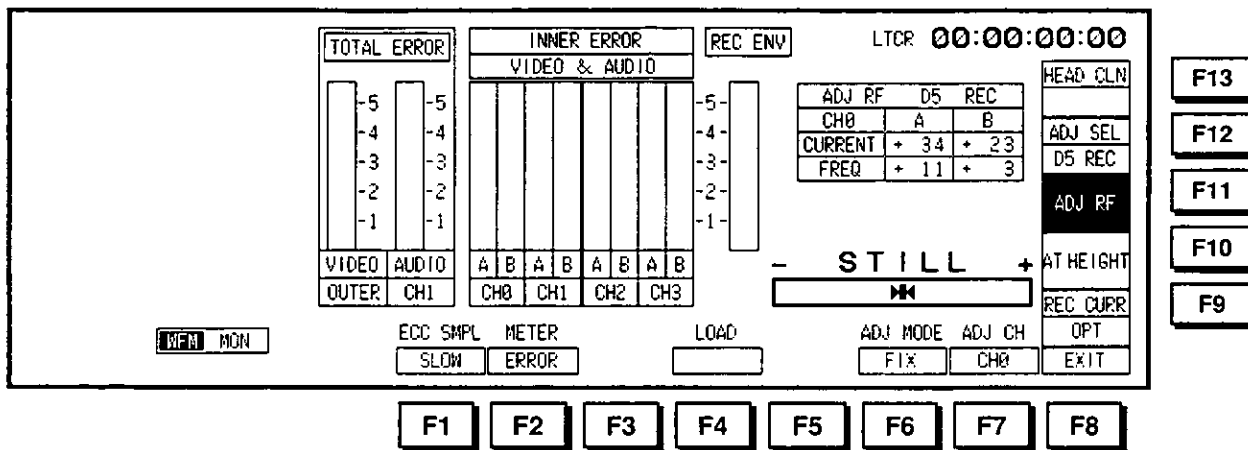

| Function key | Item | Function |
|--------------|---------------------------------------|--|
| F1-F5 | — | |
| F6 | ADJ MODE Adjust mode | FIX: The current adjustment values are held. The parameters can be re-adjusted by a remote adjustment but their values cannot be changed by this unit. AUTO EQ: When the number of errors occurring has increased, the parameters are automatically adjusted to their optimum state. |
| F7 | ADJ CH | This selects the channels to be displayed. D5 EQ/REC/PLL: CH0, CH1, CH2, CH3 |
| F8-F10 | — | |
| F11 | ADJ RF RF adjustment value display | When this key is pressed, ADJ SEL is displayed for the F12 key, and the current adjustment values of the parameters selected are displayed. The adjustment mode is selected with the F6 key and channel with the F7 key. |
| F12 | ADJ SEL | The selected RF adjustment value is displayed. D5EQ: The adjustment value of the playback equalizer in the D-5 series is displayed. D5REC: The recording adjustment value in the D-5 series is displayed. D5PLL: The relative speed adjustment value of the D-5 series PLL is displayed. |

AUDIO TEST menu

This menu appears when the **TEST** key and then the **F3** key are pressed after the tape has been ejected.

The original menu screen is returned when the cassette tape is loaded.

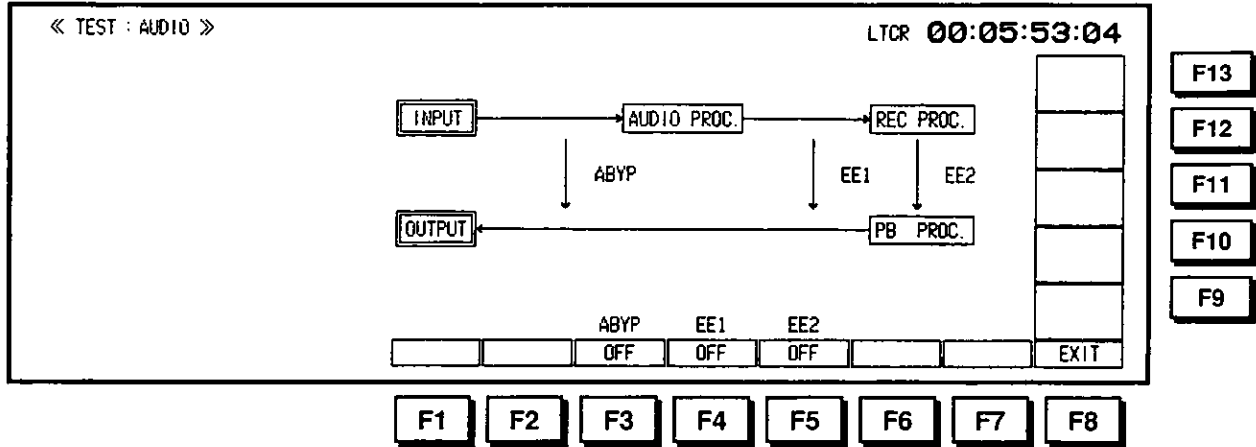

| Function key | Item | Function |
|--------------|-----------------------------|--|
| F1-F2 | — | |
| F3 | ABYP Input signal bypass | These cause the signals to bypass the audio circuitry on a block by block basis for identifying trouble locations. When one of the keys is pressed, the display of the corresponding bypass number is highlighted. |
| F4 | EE1 Input signal bypass | |
| F5 | EE2 Input signal bypass | |
| F6-F7 | — | |
| F8 | EXIT | Operation is returned to the TEST menu. |
| F9-F13 | — | |

MECHA TEST menu

This menu appears when the **TEST** key and then **F4** key are pressed.

<< TEST : MECHA >> LTCR 00:00:00:00
 - STILL +
 [RECORDING SYMBOL]
 MODE: **NORMAL** SENSOR: [] EXIT: []

F1 F2 F3 F4 F5 F6 F7 F8

F13
 F12
 F11
 F10
 F9

The menu shown below appears when the **F5** key is pressed.

<< TEST : MECHA >> LTCR 00:00:00:00
 AROUND CYLINDER AROUND REEL BASEMENT CASSETTE CARRIAGE
 [Diagram 1] [Diagram 2] [Diagram 3]
 END START
 M L HV []
 L R UD []
 - STILL +
 [RECORDING SYMBOL]
 MODE: **NORMAL** SENSOR: [] EXIT: []

F1 F2 F3 F4 F5 F6 F7 F8

F13
 F12
 F11
 F10
 F9

Function keys

| Key | Item | Function |
|--------|-----------------------------------|--|
| F1 | MODE Loading without tape | NORMAL: Normal operation NO-TAPE: Loading is enabled without a cassette tape. Loading commences when the STOP button is pressed. The cassette is selected by the F3 key. Press the EJECT button to discontinue operation at any time. |
| F2 | — | |
| F3 | C.SIZE Cassette size selection | The size of an imaginary cassette is selected when NO-TAPE has been selected by the F1 key. Cassette tape size L, M or S is selected. |
| F4 | — | |
| F5 | SENSOR Sensor operation check | When this key is pressed and highlighted, the sensor screen appears on the menu. The operations of the sensors of the cylinders, reel bases, front loading and their related parts are checked. In particular, this key is used by the servicing engineer. Return to the original screen by pressing the F8 (EXIT) key. |
| F6-F7 | — | |
| F8 | EXIT | Operation is returned to the TEST menu. |
| F9-F13 | — | |

SYSTEM TEST menu

This menu appears when the **TEST** key and then the **F5** key are pressed.

These keys on this menu are for adjustments to be made by the servicing engineer. They cannot be operated by users. Press the F8 key to return to the TEST menu.

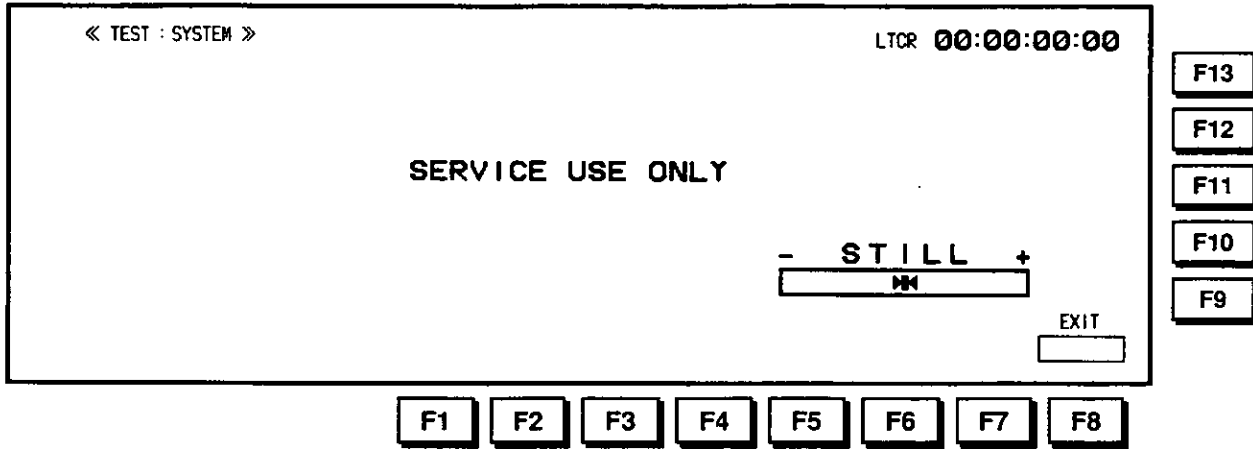

| Function key | Item | Function |
|--------------|------|---|
| F1-F7 | — | |
| F8 | EXIT | Operation is returned to the TEST menu. |
| F9-F13 | — | |

SERVO TEST menu

This menu appears when the **TEST** key and then the **F7** key are pressed.

| REEL TORQUE LOADING +107 T-REEL FWD +100 LOOSING +240 | | TOTAL ERROR | | INNER ERROR VIDEO & AUDIO | | | | REC ENV | LTR 00:00:00:00 | | ADJ ENABLE BIMORPH INIT | F13 F12 F11 F10 F9 | | | | | | | | | | | | | | | | | | | |
|---|------|------------------------|------|--|-------------|-----------|------|--------------------|---------------------|-----------|---|---|------|-----------|------|------|------------|------|------|-------------|------|------|-----------------------|---------------------|---|--|--|------------------|--|--------------------------------|--|
| AT <table border="1"> <thead> <tr> <th></th> <th>A CH</th> <th>B CH</th> </tr> </thead> <tbody> <tr> <td>NATURAL POS</td> <td>+ 37</td> <td>+ 13</td> </tr> <tr> <td>STRN DC OS</td> <td>- 7</td> <td>+ 1</td> </tr> <tr> <td>STRN GAIN</td> <td>+ 77</td> <td>+ 66</td> </tr> <tr> <td>RESONANCE</td> <td>+118</td> <td>+135</td> </tr> <tr> <td>DRIVE GAIN</td> <td>+109</td> <td>+132</td> </tr> <tr> <td>GROUP DELAY</td> <td>+ 44</td> <td>+ 36</td> </tr> </tbody> </table> | | | A CH | B CH | NATURAL POS | + 37 | + 13 | STRN DC OS | - 7 | + 1 | STRN GAIN | + 77 | + 66 | RESONANCE | +118 | +135 | DRIVE GAIN | +109 | +132 | GROUP DELAY | + 44 | + 36 | VIDEO OUTER | AUDIO CH1 | A B A B A B A B CH0 CH1 CH2 CH3 | MECHA TC DELAY : AUTO OFF | | STILL | | TRACKING OPT. ONCE MECHA | |
| | A CH | B CH | | | | | | | | | | | | | | | | | | | | | | | | | | | | | |
| NATURAL POS | + 37 | + 13 | | | | | | | | | | | | | | | | | | | | | | | | | | | | | |
| STRN DC OS | - 7 | + 1 | | | | | | | | | | | | | | | | | | | | | | | | | | | | | |
| STRN GAIN | + 77 | + 66 | | | | | | | | | | | | | | | | | | | | | | | | | | | | | |
| RESONANCE | +118 | +135 | | | | | | | | | | | | | | | | | | | | | | | | | | | | | |
| DRIVE GAIN | +109 | +132 | | | | | | | | | | | | | | | | | | | | | | | | | | | | | |
| GROUP DELAY | + 44 | + 36 | | | | | | | | | | | | | | | | | | | | | | | | | | | | | |
| TORQUE DATA SEND MEASURE AT METER PG SHIFT ADJ RATE | | OFF | | ERROR +2045 | | FINE | | EXIT | | | | | | | | | | | | | | | | | | | | | | | |
| F1 | | F2 | | F3 | | F4 | | F5 | | F6 | | | | | | | | | | | | | | | | | | | | | |
| | | | | | | | | | | F7 | | | | | | | | | | | | | | | | | | | | | |
| | | | | | | | | | | F8 | | | | | | | | | | | | | | | | | | | | | |

| Key | Item | Function |
|-----|---|---|
| F1 | TORQUE Reel torque adjustment | Key for adjustment to be made by servicing engineer. |
| F2 | DATA SEND Torque data transmission | Key for adjustment to be made by servicing engineer. |
| F3 | MEASURE Measurement | Key for adjustment to be made by servicing engineer. |
| F4 | AT AT head adjustment | Key for adjustment to be made by servicing engineer. |
| F5 | METER Error rate level display switching | ERROR: The inner error level is displayed. ENV: The envelope level is displayed. |
| F6 | PG SHIFT PG shifter adjustment | Key for adjustment to be made by servicing engineer. |
| F7 | ADJ RATE Adjust rate | Key for adjustment to be made by servicing engineer. |
| F8 | EXIT | Operation is returned to the TEST menu. |
| F9 | MECHA Mechanism adjustment | Key for adjustment to be made by servicing engineer. |
| F10 | TRACKING Tracking adjustment | Tracking does not normally need to be adjusted. It is adjusted only when it has shifted during editing. VAR: The tracking is adjusted manually. Refer to "Adjusting the tracking manually" on page 105. FIX: The tracking is fixed at the center position for manual adjustment. OPT ONCE: The tracking is optimized during playback up to the IN point for the first editing operation after inserting the cassette. It is subsequently not optimized. It is possible to optimize the tracking again. Refer to "Adjusting the tracking automatically" on page 104. OPT AUTO: The tracking is optimized during playback up to IN point each time editing is performed. Refer to "Adjusting the tracking automatically". |
| F11 | — | |
| F12 | BIMORPH INIT AT piezo-electric element hysteresis removal | Key for adjustment to be made by servicing engineer. |
| F13 | ADJ ENABLE | Key for adjustment to be made by servicing engineer. |

Error rate display

Two types of error rates are displayed:

1) TOTAL ERROR and 2) INNER ERROR.

Refer to ERROR RATE DISPLAY described on page 149 "RF TEST menu".

Tracking adjustment

For tracking adjustments, refer to the INSERT/ASSEMBLE MANUAL EDIT SET UP menu (page 104).

TEST FRONT menu

This menu appears when the **TEST** key and then the **F6** key are pressed.

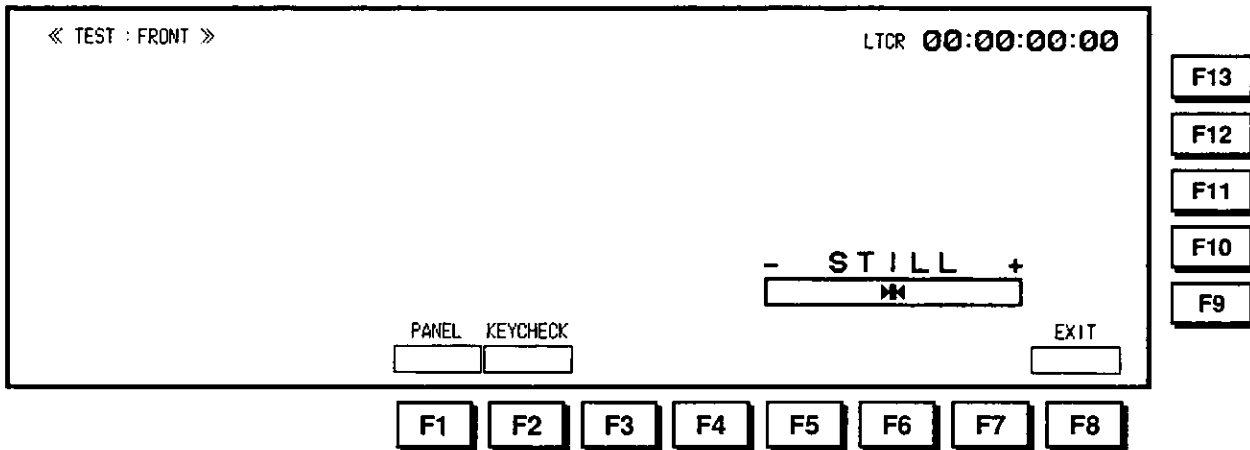

| Function key | Item | Function |
|--------------|------------------------------------|--|
| F1 | PANEL Panel display check | Operation is transferred to the TEST FRONT PANEL menu. |
| F2 | KEY CHECK Front panel key check | Operation is transferred to the TEST KEY CHECK menu. |
| F3–F7 | — | |
| F8 | EXIT | Operation is returned to the TEST menu. |
| F9–F13 | — | |

TEST FRONT KEY CHECK menu

This menu appears when the **TEST** key, then the **F6** key, and then the **F2** key are pressed after the tape has been ejected.

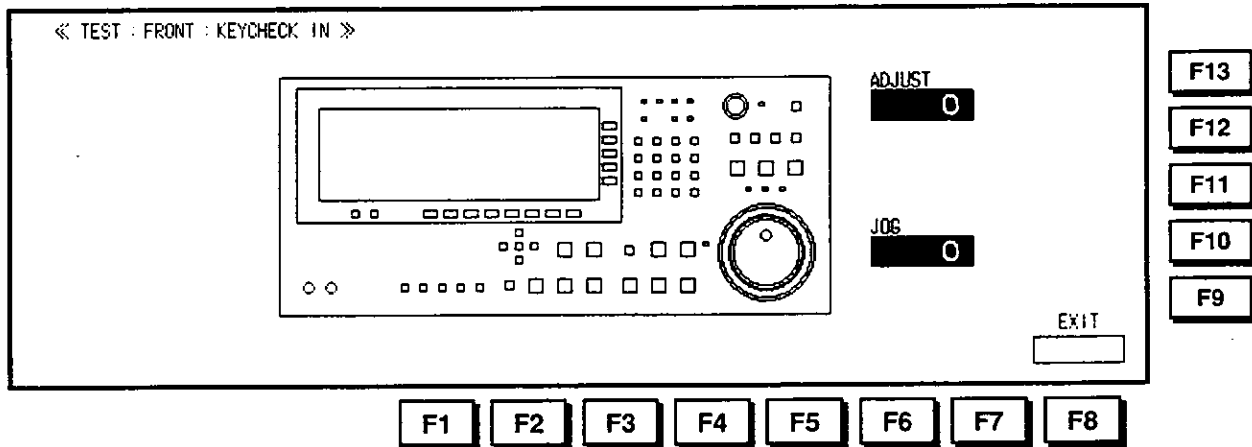

| Function Key | Item | Function |
|--------------|------|---|
| F1-F7 | — | |
| F8 | EXIT | Operation is returned to the TEST FRONT menu. |
| F9-F13 | — | |

TEST FRONT PANEL menu

This menu appears when the **TEST** key, then the **F6** key, and then the **F1** key are pressed.

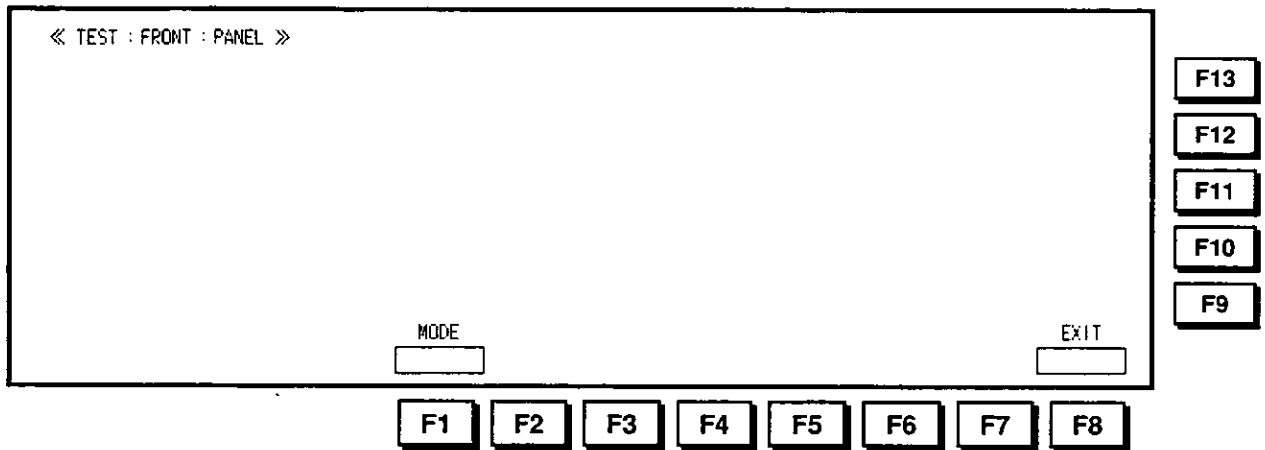

| Function Key | Item | Function |
|--------------|---------------------------|--|
| F1 | MODE Display dot check | The entire display panel is lighted in a predetermined pattern, and the display dots are checked. Each time the key is pressed, one of the 10 patterns is displayed. |
| F2–F7 | — | |
| F8 | EXIT | Operation is returned to the TEST FRONT menu. |
| F9–F13 | — | |

□ Dial/control

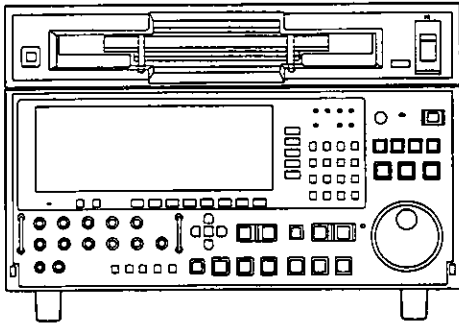

When the ADJUST control or search dial is turned, the pulse count is displayed.

□ LEDs

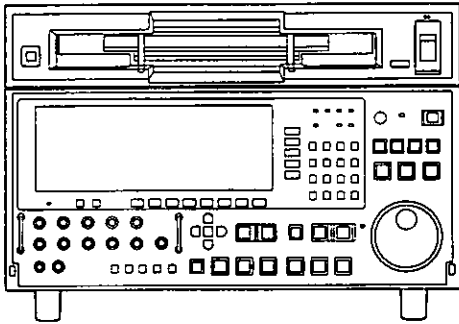

Each time the F1 key is pressed, one of the LEDs on the panel is lighted to check its operation.

□ Keys

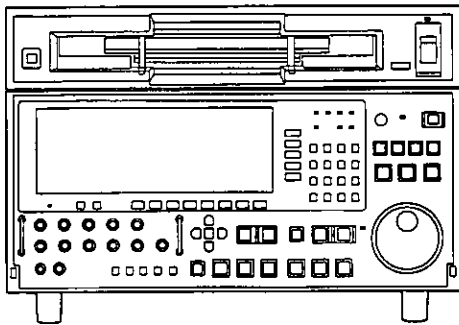

When a key (or button) on the panel is pressed, the corresponding key on the menu screen is highlighted and the buzzer sounds at the same time. This makes it possible to verify that the front micro-computer has recognized that a key (or button) has been pressed.

Insertion of IC Card

The instruction given below is to be performed in addition to the steps explained on page 175 of the Instruction Manual.

The slot for inserting IC cards is located on the right side at the back of the front panel.

Use this slot to insert the IC cards when using the TEST IC CARD menu.

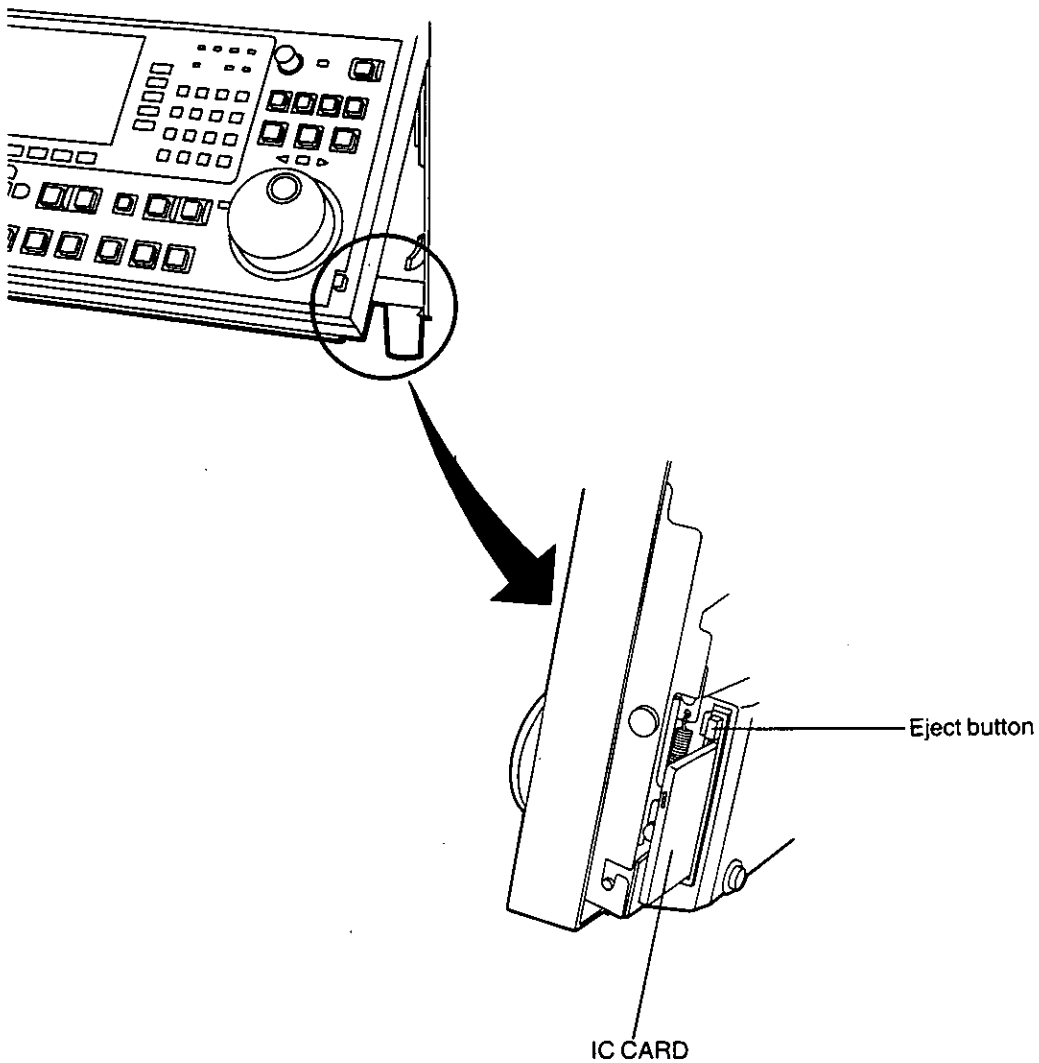

TEST, IC CARD Menu

The following menu appears when the **F13** key is pressed after pressing the **TEST** key.

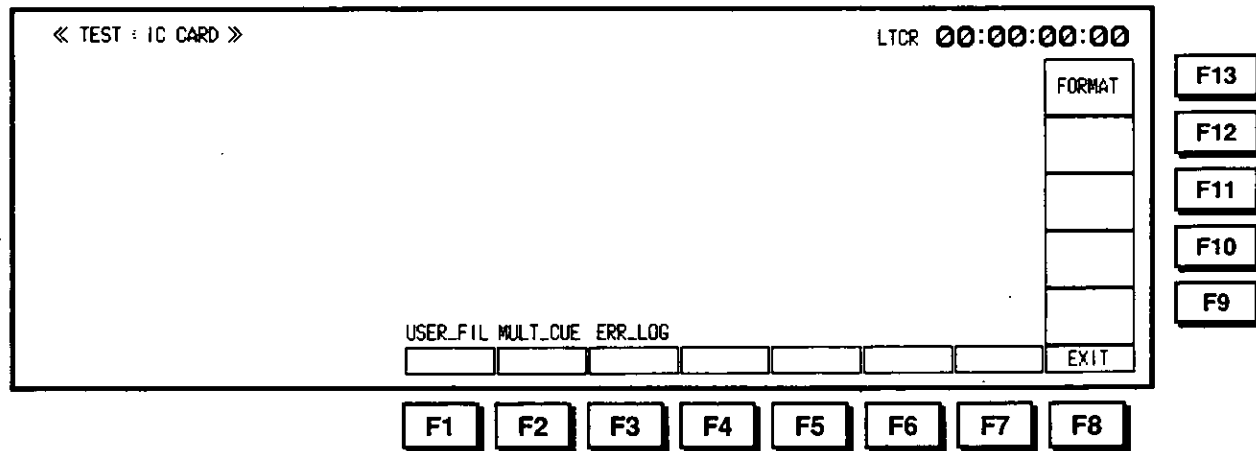

| Function key | Item | Function |
|--------------|----------|---|
| F1 | USER_FIL | Controls user files using the IC CARD. Pressing the F key switches to the USER_FILE menu. <ul style="list-style-type: none"> •Includes functions to load and save the current deck status as well as all registered files. •Enables selection of whether to also send SYS H and SYS SC when transferring user files to the deck. |
| F2 | MULT_CUE | Loads and saves 100 cue points (MULTI CUE) on the IC CARD. Pressing the F key switches to the MULTI_CUE menu. <ul style="list-style-type: none"> •Enables selection of whether to transfer all pages at once or selection of the pages to be transferred. |
| F3 | ERR_LOG | This function stores the deck mode, time and type of warning in the memory when warnings occur. (This function is only valid when the power is on.) <ul style="list-style-type: none"> •Includes a function to store 50-step data in the memory. •Includes a function to select whether to replace old warnings with new warnings when the memory buffer is full. •Includes a function to store this data on the IC CARD. •Includes a function to monitor IC CARD data. |
| F4-F7 | — | |
| F8 | EXIT | Returns operation to the TEST menu. |
| F9-F12 | — | |
| F13 | FORMAT | Formats the IC CARD. Care should be taken as this will erase all data on the IC CARD. Pressing the F13 (FORMAT), F and C keys simultaneously formats the IC CARD. |

TEST, IC CARD, USER Menu

The following menu appears when the **F13** and **F1** keys are pressed after pressing the **TEST** key.

| « TEST : IC CARD : USER » | | | | LTCR 00:00:00:00 | | | | | | | | | | | | | | | | | | | | |
|--|--------------------------|-----------|--------------------------|------------------|-----------|--------|-------|---------|-------|------|-----|-----|----|----|-----|-----|------|---|--|---------------------|---------------------|-------------------|---------------------|-------------------|
| FILE NAME | LOCK | FILE NAME | LOCK | TRNS MD | | | | | | | | | | | | | | | | | | | | |
| | | 5 | <input type="checkbox"/> | FILE5-10 | | | | | | | | | | | | | | | | | | | | |
| | | 6 | <input type="checkbox"/> | | | | | | | | | | | | | | | | | | | | | |
| 1 | <input type="checkbox"/> | 7 | <input type="checkbox"/> | | | | | | | | | | | | | | | | | | | | | |
| 2 | <input type="checkbox"/> | 8 | <input type="checkbox"/> | | | | | | | | | | | | | | | | | | | | | |
| 3 | <input type="checkbox"/> | 9 | <input type="checkbox"/> | | | | | | | | | | | | | | | | | | | | | |
| 4 | <input type="checkbox"/> | 10 | <input type="checkbox"/> | | | | | | | | | | | | | | | | | | | | | |
| <table border="1"> <tr> <td>LOAD</td> <td>FILE SAVE</td> <td>DELETE</td> <td>UP_LD</td> <td>DOWN_LD</td> <td>W/SYS</td> <td>LOCK</td> </tr> <tr> <td></td> <td></td> <td></td> <td></td> <td></td> <td>OFF</td> <td>EXIT</td> </tr> </table> | | | | LOAD | FILE SAVE | DELETE | UP_LD | DOWN_LD | W/SYS | LOCK | | | | | | OFF | EXIT | <table border="1"> <tr> <td>A B C D E F G H I J</td> </tr> <tr> <td>K L M N O P Q R S T</td> </tr> <tr> <td>U V W X Y Z 0 1 2</td> </tr> <tr> <td>3 4 5 6 7 8 9 < = ></td> </tr> <tr> <td>? : + * - () _ .</td> </tr> </table> | | A B C D E F G H I J | K L M N O P Q R S T | U V W X Y Z 0 1 2 | 3 4 5 6 7 8 9 < = > | ? : + * - () _ . |
| LOAD | FILE SAVE | DELETE | UP_LD | DOWN_LD | W/SYS | LOCK | | | | | | | | | | | | | | | | | | |
| | | | | | OFF | EXIT | | | | | | | | | | | | | | | | | | |
| A B C D E F G H I J | | | | | | | | | | | | | | | | | | | | | | | | |
| K L M N O P Q R S T | | | | | | | | | | | | | | | | | | | | | | | | |
| U V W X Y Z 0 1 2 | | | | | | | | | | | | | | | | | | | | | | | | |
| 3 4 5 6 7 8 9 < = > | | | | | | | | | | | | | | | | | | | | | | | | |
| ? : + * - () _ . | | | | | | | | | | | | | | | | | | | | | | | | |
| <table border="1"> <tr> <td>F1</td> <td>F2</td> <td>F3</td> <td>F4</td> <td>F5</td> <td>F6</td> <td>F7</td> <td>F8</td> <td>F9</td> <td>F10</td> <td>F11</td> <td>F12</td> <td>F13</td> </tr> </table> | | | | | | F1 | F2 | F3 | F4 | F5 | F6 | F7 | F8 | F9 | F10 | F11 | F12 | F13 | | | | | | |
| F1 | F2 | F3 | F4 | F5 | F6 | F7 | F8 | F9 | F10 | F11 | F12 | F13 | | | | | | | | | | | | |

| Function key | Item | Function |
|--------------|---------|---|
| F1 | LOAD | Calls up IC CARD user files. ●Pressing the F1 and F keys simultaneously executes LOAD. |
| F2 | SAVE | Registers IC CARD user files. ●Pressing the F2 and F keys simultaneously executes SAVE. |
| F3 | DELETE | Deletes IC CARD user files. ●Pressing the F3 and F keys simultaneously executes DELETE. |
| F4 | — | |
| F5 | UP_LD | Loads registered files from the IC CARD to the deck. ●Pressing hte F5 and F keys simultaneously executes UP_LD. |
| F6 | DOWN_LD | Loads registered files from the deck to the IC CARD. ●Pressing the F6 and F keys simultaneously executes DOWN_LD. |
| F7 | W/SYS | Selects whether to transfer card data or to use original deck data for SYS H and SYS SC when transferring user files from the IC CARD to the deck. ON: Sends card data for SYS H and SYS SC. OFF: Uses original deck data for SYS H and SYS SC. This function is only valid during LOAD (F1) and UP_LD (F5). |
| F8 | EXIT | Returns operation to the IC CARD menu. |
| F9 | LOCK | This locks and unlocks user files. ●Pressing the F9 and F keys simultaneously executes LOCK. |
| F10-F12 | — | |
| F13 | TRNS MD | This selects whether to load files 5 to 10 or to load all files 1 to 10 when loading registered files from the IC CARD to the deck. FILES-10: Loads files 5 to 10 from the IC CARD to the deck. ALL: Loads all files 1 to 10 from the IC CARD to the deck. Press the F13, F and C keys simultaneously to select ALL. This function is only valid during UP_LD (F5). |

TEST, IC CARD, MULTI CUE Menu

The following menu appears when the **F13** and **F2** keys are pressed after pressing the **TEST** key.

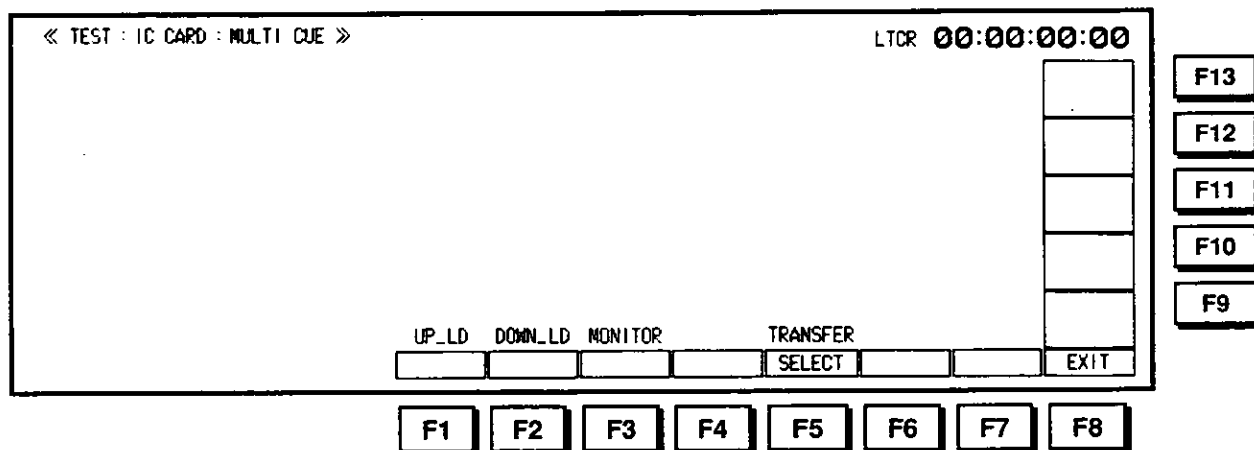

| Function key | Item | Function |
|--------------|----------|---|
| F1 | UP_LD | Loads registered files from the IC CARD to the deck. •Pressing the F1 and F keys simultaneously executes UP_LD. If a page is write-protected, the message "PROTECTED PAGE" is displayed and UP_LD cannot be executed. To execute UP_LD, cancel write protection or stop transfer to the protected page. Operation automatically switches to the deck MULTI_CUE menu after execution. |
| F2 | DOWN_LD | Loads registered files from the deck to the IC CARD. Operation automatically switches to the MONITOR menu after execution. (Pressing the F2 and F keys simultaneously execute DOWN_LD.) |
| F3 | MONITOR | Displays MULTI CUE data saved on the IC CARD. |
| F4 | — | |
| F5 | TRANSFER | Switches whether to transfer all pages or one page at a time when performing UP_LD from the IC CARD to the deck. ALL: Transfers all pages. SELECT UP: Switches to the page select menu when UP_LD is executed. |
| F6–F7 | — | |
| F8 | EXIT | Returns operation to the IC CARD menu. |
| F9–F13 | — | |

TEST, IC CARD, MULTI CUE, SELECT Menu

The following menu appears when the **F13** and **F2** keys are pressed and then the **F1** and **F** keys are pressed simultaneously after pressing the **TEST** key.

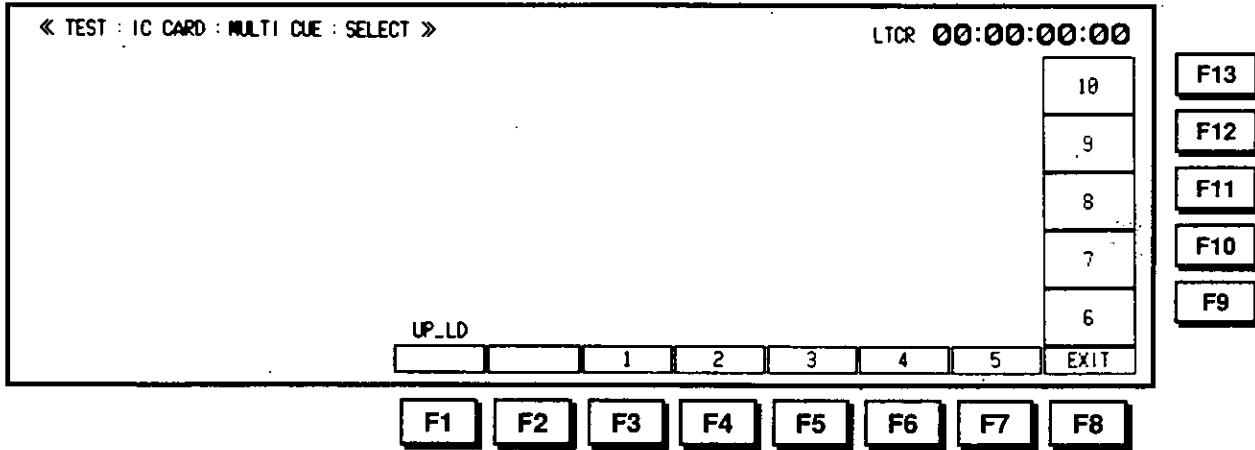

| Function key | Item | Function |
|--------------|-------|---|
| F1 | UP_LD | Pressing the "UP_LD" key after selecting the pages to be transferred loads the selected files from the IC_CARD to the deck. |
| F2 | — | |
| F3–F7 | | Selects the pages to be transferred. |
| F8 | EXIT | Returns operation to the IC CARD MULTI CUE menu. |
| F9–F13 | | Selects the pages to be transferred. |

TEST, IC CARD, MULTI CUE, MONITOR Menu

The following menu appears when the [F13], [F2] and then [F3] keys are pressed after pressing the [TEST] key.

« TEST : IC CARD : MULTI CUE : MONITER »

LTOR 00:00:00:00

| | | | | | |
|---|-------------|----|-------------|------|-----|
| 1 | 00:00:00:00 | 7 | 00:00:00:00 | 10 | |
| 2 | 00:00:00:00 | 8 | 00:00:00:00 | 9 | F13 |
| 3 | 00:00:00:00 | 9 | 00:00:00:00 | 8 | F12 |
| 4 | 00:00:00:00 | 10 | 00:00:00:00 | 7 | F11 |
| 5 | 00:00:00:00 | | | 6 | F10 |
| 6 | 00:00:00:00 | | | EXIT | F9 |

2

3

4

5

EXIT

F1

F2

F3

F4

F5

F6

F7

F8

| Function key | Item | Function |
|--------------|---------------------------------|---|
| F1-F2 | — | |
| F3-F7 | 1-5 Cue no. 1-5 assignment | |
| F8 | EXIT | This transfers operation to the IC CARD MULTI CUE menu. |
| F9-F13 | 6-10 Cue no. 6-10 assignment | |

TEST, IC CARD, ERR LOG Menu

The following menu appears when the **F13** and **F3** keys are pressed after pressing the **TEST** key.

« TEST : IC CARD : ERROR LOG » LTCR 00:00:00:00

| | | | | | | | | | | | | | | | | | | | | | | | | | | | | | | | | | | | | | | | | | | | | | | | | | | | | | |
|----------------------|-----------|--|---|---|---|---|---|---|---|---|---|---|---|---|---|---|---|---|---|---|---|---|---|---|---|---|---|---|---|---|---|--|---|---|---|---|---|---|---|---|---|---|---|---|---|---|---|---|---|---|---|---|---------|
| FILE NAME | FILE NAME | <table border="1" style="font-size: small;"> <tr><td>A</td><td>B</td><td>C</td><td>D</td><td>E</td><td>F</td><td>G</td><td>H</td><td>I</td><td>J</td></tr> <tr><td>K</td><td>L</td><td>M</td><td>N</td><td>O</td><td>P</td><td>Q</td><td>R</td><td>S</td><td>T</td></tr> <tr><td>U</td><td>V</td><td>W</td><td>X</td><td>Y</td><td>Z</td><td>0</td><td>1</td><td>2</td><td></td></tr> <tr><td>3</td><td>4</td><td>5</td><td>6</td><td>7</td><td>8</td><td>9</td><td><</td><td>=</td><td>></td></tr> <tr><td>?</td><td>:</td><td>+</td><td>*</td><td>-</td><td>(</td><td>)</td><td>.</td><td>.</td><td>.</td></tr> </table> | A | B | C | D | E | F | G | H | I | J | K | L | M | N | O | P | Q | R | S | T | U | V | W | X | Y | Z | 0 | 1 | 2 | | 3 | 4 | 5 | 6 | 7 | 8 | 9 | < | = | > | ? | : | + | * | - | (|) | . | . | . | INITIAL |
| A | B | C | D | E | F | G | H | I | J | | | | | | | | | | | | | | | | | | | | | | | | | | | | | | | | | | | | | | | | | | | | |
| K | L | M | N | O | P | Q | R | S | T | | | | | | | | | | | | | | | | | | | | | | | | | | | | | | | | | | | | | | | | | | | | |
| U | V | W | X | Y | Z | 0 | 1 | 2 | | | | | | | | | | | | | | | | | | | | | | | | | | | | | | | | | | | | | | | | | | | | | |
| 3 | 4 | 5 | 6 | 7 | 8 | 9 | < | = | > | | | | | | | | | | | | | | | | | | | | | | | | | | | | | | | | | | | | | | | | | | | | |
| ? | : | + | * | - | (|) | . | . | . | | | | | | | | | | | | | | | | | | | | | | | | | | | | | | | | | | | | | | | | | | | | |
| MACHINE CURRENT DATA | 5 | | | | | | | | | | | | | | | | | | | | | | | | | | | | | | | | | | | | | | | | | | | | | | | | | | | | |
| 1 | 6 | | | | | | | | | | | | | | | | | | | | | | | | | | | | | | | | | | | | | | | | | | | | | | | | | | | | |
| 2 | 7 | | | | | | | | | | | | | | | | | | | | | | | | | | | | | | | | | | | | | | | | | | | | | | | | | | | | |
| 3 | 8 | | | | | | | | | | | | | | | | | | | | | | | | | | | | | | | | | | | | | | | | | | | | | | | | | | | | |
| 4 | 9 | | | | | | | | | | | | | | | | | | | | | | | | | | | | | | | | | | | | | | | | | | | | | | | | | | | | |
| | 10 | | | | | | | | | | | | | | | | | | | | | | | | | | | | | | | | | | | | | | | | | | | | | | | | | | | | |

DOWN_LD
MONITOR
DELETE
AUTOSTEP
OFF
EXIT

F1
F2
F3
F4
F5
F6
F7
F8

F13
F12
F11
F10
F9

| Function key | Item | Function |
|--------------|-----------|--|
| F1 | DOWN_LD | Loads data currently stored in the memory from the deck to the IC CARD. The serial No., software version and operation time are also saved at this time. When there is no ERROR_LOG data, "ERROR" is displayed and DOWN_LD cannot be executed. ●Pressing the F1 and F key simultaneously executes DOWN_LD. |
| F2 | MONITOR | Displays ERROR_LOG data saved on the IC CARD. After downloading MACHINE CURRENT DATA, the ERROR LOG data currently stored in the deck is displayed. |
| F3 | DELETE | Deletes ERROR_LOG data saved on the IC CARD. ●Pressing the F3 and F key simultaneously executes DELETE. |
| F4 | — | |
| F5 | AUTO_STEP | Selects whether to delete warnings in order from the oldest when the number of warnings exceeds the buffer capacity. ON: Old warnings are constantly replaced. OFF: Old warnings are not replaced when buffer is full. |
| F6-F7 | — | |
| F8 | EXIT | Returns operation to the IC CARD menu. |
| F9-F12 | — | |
| F13 | INITIAL | Deletes all past ERROR_LOG data currently stored in the deck memory as well as all currently displayed ERROR_LOG data. After INITIAL is executed, if DOWN_LD is selected while there is no ERROR_LOG data, "ERROR" will be displayed because there is no ERROR_LOG data and DOWN_LD cannot be executed. |

TEST, IC CARD, ERR LOG, MONITOR Menu

The following menu appears when the **F13**, **F3** and then **F2** keys are pressed after pressing the **TEST** key.

« TEST : IC CARD : ERROR LOG : MONITER »

| | | | | |
|--------------------------|-------|-----------------------|------------------------|------------------|
| NO WARNING | MODE | OFF_TAPE TIME CODE | SERIAL NO. : J4TMA0009 | LTCR 00:00:00:00 |
| 1. NO EXTERNAL REFERENCE | EJECT | 00:00:00:00 | SOFTWARE VERSION: | |
| 2. | | | FRONT : FP-N1. 15. E | |
| 3. | | | SYSCON : S5-N1. 23. E | |
| 4. | | | TC : S3-N1. 05. - | |
| 5. | | | AV : S5-N1. 27. F | |
| 6. | | | SERVO : S4-N1. 10. - | |
| 7. | | | OPERATION TIME | |
| 8. | | | OPERATION : 382 HOURS | |
| | | | HD ROTATION : 53 HOURS | |
| | | | TAPE TRAVEL : 68 HOURS | |
| | | | THREADING : 325 TIMES | |

TOTAL 1 / 1

EXIT

F1

F2

F3

F4

F5

F6

F7

F8

F13

F12

F11

F10

F9

| Function key | Item | Function |
|--------------|------|--|
| F1-F7 | — | |
| F8 | EXIT | Returns operation to the IC_CARD ERROR_LOG menu. |
| F9-F13 | — | |

●When the number of errors exceeds the number which can be displayed on the front panel, the error display can be scrolled using the SCROLL key.

Error messages

This unit displays four different kinds of error messages.

(1) DIAG menu

The "W" warning mark flashes at the top left of the menu screen when settings have been made incorrectly, conditions have not been checked, a warning has been given or there is some other problem with the unit's operation.

The error message appears on the screen when the DIAG key is pressed.

(2) AUTO OFF mode

When trouble occurs and continued use of the unit in this state is not possible, the AUTO OFF lamp and SYSTEM lamp light on the front panel, and an error message appears on the display.

(3) System errors

When trouble occurs and the unit's operation can no longer be guaranteed, the SYSTEM lamp lights on the front panel, and an error message appears on the display.

(4) Operational errors

When the wrong button or key is pressed during operation or an error is made in input, an operation guidance message appears at the bottom right of the screen.

DIAG menu error messages

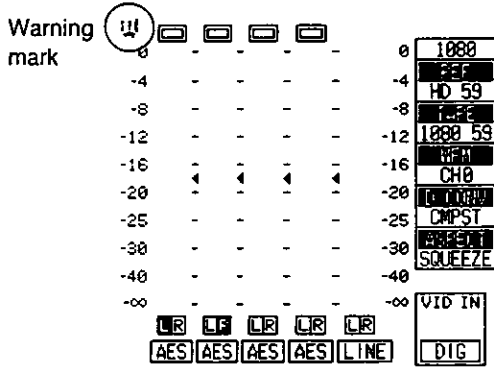

The "W" warning mark flashes at the top left of the screen when settings have been made incorrectly, conditions have not been checked, a warning has been given or there is some other problem with the unit's operation.

If the DIAG key is pressed when a warning has been given, an error message appears on the display.

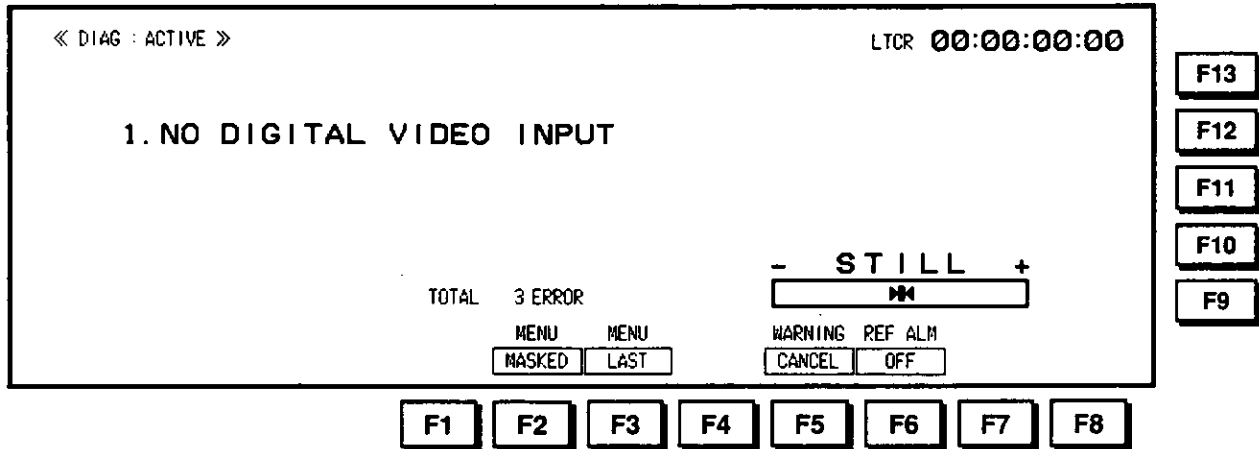

There are the following three DIAG menu screens:

- ACTIVE screen** This is the first screen to appear when the DIAG key is pressed. It displays the error message corresponding to the warning item which has not been masked (canceled).
- MASKED screen** This appears when the F2 (MASKED) key is pressed. It displays the error message corresponding to the warning item which has been masked (canceled).
- LAST screen** This appears when the F3 (LAST) key is pressed. It displays the error messages for the last three warnings given.

- Error messages disappear from the screen once the error has been eliminated.

ACTIVE screen

If the DIAG key is pressed when the warning mark is displayed, the DIAG menu (ACTIVE screen) shown below appears.

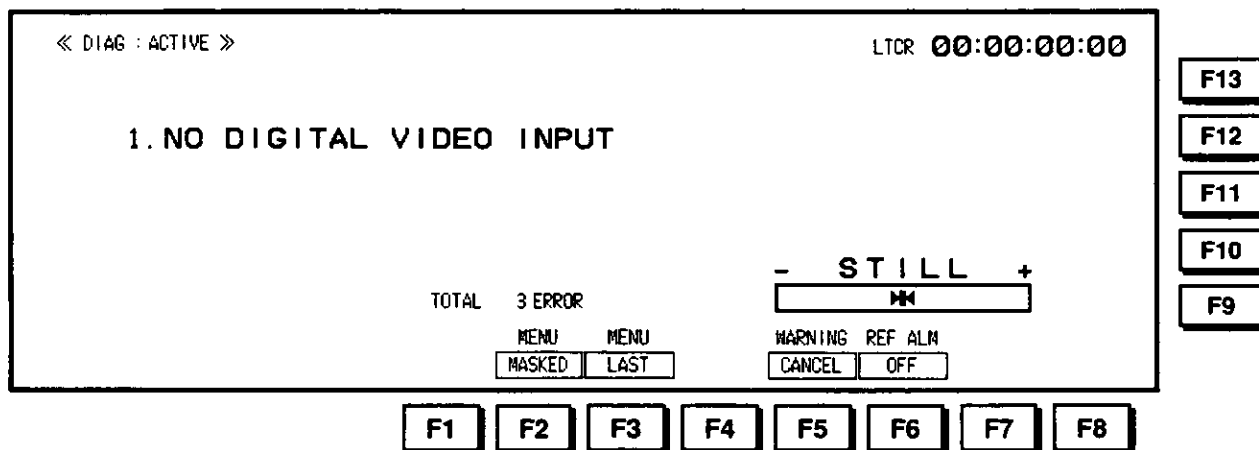

| Function key | Item | Function |
|--------------|----------------|---|
| F1 | — | |
| F2 | MENU MASKED | Operation is transferred to the MASKED screen. |
| F3 | MENU LAST | Operation is transferred to the LAST screen. |
| F5 | WARNING CANCEL | The warning item currently displayed on the ACTIVE screen is masked (canceled). The error message corresponding to the masked warning item will appear on the MASKED screen. |
| F6 | REF ALM | ON: The STOP lamp is made to flash when a reference signal is not supplied. OFF: The STOP lamp is not made to flash when a reference signal is not supplied. |
| F7-F13 | — | |

When a multiple number of warnings are given

- The error messages are displayed starting with the one having the highest priority.
- All the messages can be viewed in succession using the ▲ and ▼ cursor keys.
- The total number of warnings is also displayed.

MASKED screen

When the F2 (MASKED) key is pressed on the ACTIVE or LAST screen, the DIAG menu (MASKED screen) shown below appears.

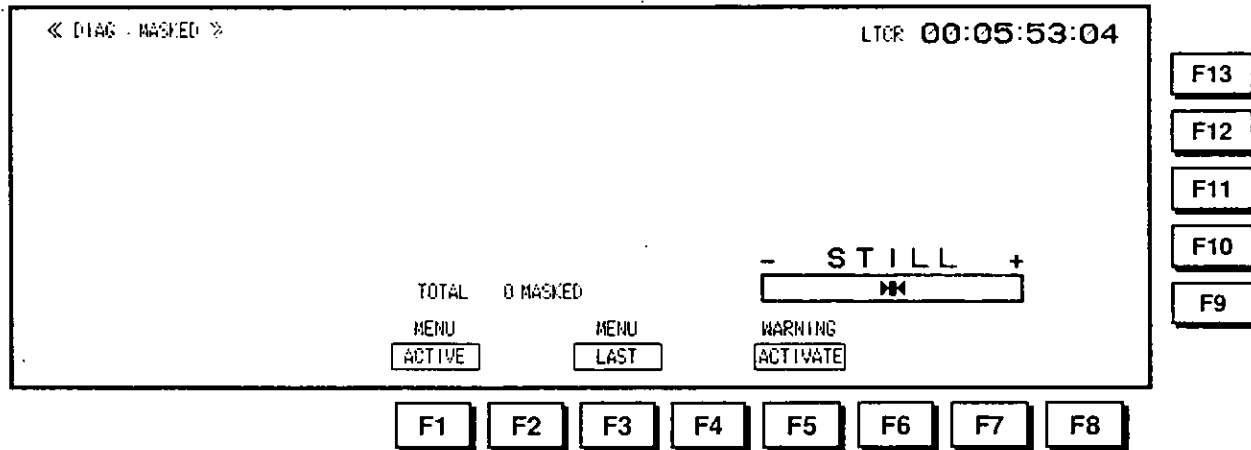

| Function key | Item | Function |
|--------------|---------------------|---|
| F1 | MENU ACTIVE | Operation is transferred to the ACTIVE screen. |
| F2 | — | |
| F3 | MENU LAST | Operation is transferred to the LAST screen. |
| F4 | — | |
| F5 | WARNING ACTIVATE | The masking (cancellation) of the currently displayed warning item is released. The masking of the warning item currently displayed on the MASKED screen is released. The error message corresponding to the warning item whose masking has been released will appear on the ACTIVE screen. |
| F6-F13 | — | |

When a multiple number of warnings are given

- The error messages are displayed starting with the one having the highest priority.
- All the messages can be viewed in succession using the ▲ and ▼ cursor keys.
- The total number of warnings is also displayed.

LAST screen

When the F3 (LAST) key is pressed on the ACTIVE or MASKED screen, the DIAG menu (LAST screen) shown below appears.

- It displays the error messages for the last three warnings given.

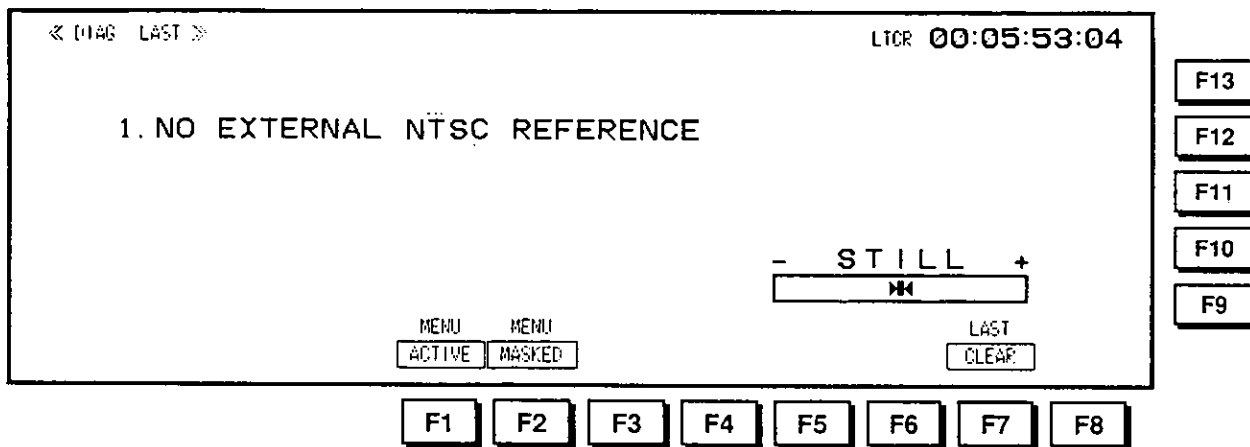

| Function key | Item | Function |
|--------------|-------------|--|
| F1 | MENU ACTIVE | Operation is transferred to the ACTIVE screen. |
| F2 | MENU MASKED | Operation is transferred to the MASKED screen. |
| F3–F6 | — | |
| F7 | LAST CLEAR | All the warnings displayed on the current LAST screen are cleared. When the F key and F7 (LAST CLEAR) key are pressed together, all the warnings displayed on the current LAST screen are cleared. When a new warning is given, its details are displayed. |
| F8–F13 | — | |

When a multiple number of warnings are given

- The error messages are displayed starting with the last one first.
- All the messages can be viewed in succession using the ▲ and ▼ cursor keys.

ERROR messages

| No. | Message | Error description | Remedial action |
|-----|---|---|------------------|
| 3 | DIGITAL AUDIO NOT LOCKED TO INPUT VIDEO | The digital audio input signal is not locked to the video input signal. | |
| 4 | DIGITAL AUDIO NOT LOCKED TO INTERNAL REF | The audio PLL is not locked. | |
| 6 | HIGH ERROR RATE | The error rate is high. | |
| 9 | VIDEO CONCEAL SWITCH OFF Conceal SW on L4 board is set to off. | CONCEAL switch on L4 VIDEO PB board is OFF. | Set it ON. |
| 10 | INNER ECC SW OFF Inner Ecc SW on L4 board is set to off. | INNER ECC switch on L4 VIDEO PB board is OFF. | Set it ON. |
| 11 | OUTER VIDEO ECC SW OFF Outer Video Ecc SW on L4 board is set to off. | OUTER ECC switch on L4 VIDEO PB board is OFF. | Set it ON. |
| 12 | OUTER AUDIO ECC SW OFF Outer Audio Ecc SW on L4 board is set to off. | OUTER AUDIO ECC switch on L4 VIDEO PB board is OFF. | Set it ON. |
| 13 | NO EXTERNAL NTSC REFERENCE | The reference signal is not supplied to the NTSC REF INPUT connector. | Check the input. |
| 14 | NO COLOR BURST IN NTSC REF | No burst in NTSC reference video signal. | |
| 15 | NO STANDARD SCH-RANGE IN REF | Problem with SCH of NTSC reference signal. | |
| 18 | INPUT D AUDIO CH1/2 CRCC ERROR CONFIRM INPUT DIGITAL AUDIO | CRCC error has occurred in the status of the AES/EBU signal supplied to CH1/2. | Check the input. |
| 19 | INPUT D AUDIO CH3/4 CRCC ERROR CONFIRM INPUT DIGITAL AUDIO | CRCC error has occurred in the status of the AES/EBU signal supplied to CH3/4. | Check the input. |
| 20 | INPUT DIGITAL AUDIO CH1/2 PARITY ERROR CONFIRM INPUT DIGITAL AUDIO | A parity error has occurred in the status of the AES/EBU signals supplied to CH1/2. | Check the input. |
| 21 | INPUT DIGITAL AUDIO CH3/4 PARITY ERROR CONFIRM INPUT DIGITAL AUDIO | A parity error has occurred in the status of the AES/EBU signals supplied to CH3/4. | Check the input. |

| No. | Message | Error description | Remedial action |
|-----|--|---|-----------------------------|
| 22 | INPUT DIGITAL AUDIO CH1/2 SYNC ERROR CONFIRM INPUT DIGITAL AUDIO | A sync error has occurred in the status of the AES/EBU signals supplied to CH1/2. | Check the input. |
| 23 | INPUT DIGITAL AUDIO CH3/4 SYNC ERROR CONFIRM INPUT DIGITAL AUDIO | A sync error has occurred in the status of the AES/EBU signals supplied to CH3/4. | Check the input. |
| 24 | AUDIO CONCEAL SW OFF | The AUDIO CONCEAL SW on the L4 VIDEO PB board is OFF. | Set this switch to ON. |
| 27 | LOW RF | The RF playback level has dropped. | Clean the heads. |
| 32 | AUDIO VARIABLE INPUT LEVEL IN DIGITAL MODE | The input level is at the VAR value setting despite the fact that digital audio input signals have been selected. | |
| 33 | VIDEO VARIABLE OUTPUT LEVEL IN DIGITAL MODE | The output level Y, P _B and P _R are at the VTR value settings despite the fact that digital video input signals have been selected. | |
| 150 | RECEIVED INVALID COMMAND FROM RS 422 PORT | An undefined command has been received. | Check the command received. |
| 151 | SUM-CHECK ERROR IN RECEIVED COMMAND FROM RS-422 PORT | A checksum error has occurred in the command received. | Check the command received. |
| 152 | PARITY ERROR IN RECEIVED COMMAND FROM RS-422 PORT | A parity error has occurred in the command received. | Check the command received. |
| 153 | FRAMING ERROR IN RECEIVED COMMAND FROM RS-422 PORT | A framing error has occurred in the command received. | Check the command received. |
| 154 | OVER-RUN ERROR IN RECEIVED COMMAND FROM RS-422 PORT | An overrun error has occurred in the command received. | Check the command received. |
| 155 | RS-422 COMMUNICATION STOP BY TIME OUT | A time-out error has occurred. | Check the command received. |
| 165 | RECEIVED INVALID COMMAND FROM RS-232C PORT | An undefined command has been received. | Check the command received. |
| 166 | SUM-CHECK ERROR IN RECEIVED COMMAND FROM RS-232C PORT | A checksum error has occurred in the command received. | Check the command received. |

| No. | Message | Error description | Remedial action |
|-----|--|--|--|
| 167 | PARITY ERROR IN RECEIVED COMMAND FROM RS-232C PORT | A parity error has occurred in the command received. | Check the command received. |
| 168 | FRAMING ERROR IN RECEIVED COMMAND FROM RS-232C PORT | A framing error has occurred in the command received. | Check the command received. |
| 169 | OVER-RUN ERROR IN RECEIVED COMMAND FROM RS-232C PORT | An overrun error has occurred in the command received. | Check the command received. |
| 170 | RS-232C COMMUNICATION STOP BY TIME OUT | A time-out error has occurred. | Check the command received. |
| 180 | OUT OF RANGE FOR LTCR READING | The LTCR reading is outside the allowable range. (Interpolation display) | |
| 181 | NO LTC RECORDING IN TAPE | LTC is not recorded on the tape. (Interpolation display) | Check the heads and S3 circuit board. |
| 182 | DATA ERROR IN LTCR | LTCR data error. (Interpolation display) | Check the heads and S3 circuit board. |
| 183 | OUT OF RANGE FOR VITC READING | The VITC reading is outside the allowable range. (Interpolation display) | |
| 184 | NO VITC RECORDING IN TAPE | VITC is not recorded on the tape. (Interpolation display) | |
| 185 | DATA ERROR IN VITCR | VITCR data error. (Interpolation display) | Check the VIDEO and AT operations. |
| 186 | NO EXT TC | No external time code has been supplied. | Check the cable and connector connections. |
| 187 | DATA ERROR IN EXT TC | EXT TC data error. | Check the input signal. |
| 189 | NO CUE ERASE CURRENT | No erase current is flowing to the CUE erase head. | |
| 190 | NO TC ERASE CURRENT | No erase current is flowing to the TC erase head. | |
| 191 | NO FULL ERASE CURRENT | No erase current is flowing to the full erase head. | |
| 192 | NO CTL ERASE CURRENT | No erase current is flowing to the CTL erase head. | |

| No. | Message | Error description | Remedial action |
|-----|-------------------------------------|--|---|
| 250 | SERVO UNLOCK | The servo was unlocked for more than 3 seconds in the PLAY, REC-PLAY or EDIT-REC mode. | |
| 261 | CTL NOT DETECTED | The CTL has not been recorded on the tape. | |
| 265 | MISTRACK IN OPTIMIZED TRACKING DATA | Tracking optimizing was not completed successfully. | Check the tape playback mode. |
| 266 | WRONG OPTIMIZED TRACKING VALUE | Envelope has dropped by 25% from the level at the completion of the tracking optimizing. | |
| 267 | CTL HEAD CLOGGING | CTL head is clogged. | Clean the CTL head. |
| 275 | IC CARD LOW BATTERY | The remaining charge of the battery incorporated inside the IC card is low. | Replace the battery inside the IC card. |
| 276 | CONCEAL A | Errors were corrected in the PCM audio data. | Check the tape playback mode. |
| 277 | CONCEAL V | Errors were corrected in the video data. | Check the tape playback mode. |
| 278 | AUDIO MUTE | The audio output was muted. | Check the tape playback mode. |
| 300 | VITC ERROR IN SERIAL DIGITAL INPUT | A transmission error was detected from the VITC signal in the HD serial input signals. | Check the input. |
| 301 | LTC ERROR IN SERIAL DIGITAL INPUT | A transmission error was detected from the LTC signal in the HD serial input signals. | Check the input. |
| 302 | 3D CONCEAL | 3-dimensional errors were corrected in the video data. | Check the tape playback mode. |
| 303 | L2 PLL 36M NOT LOCKED | PLL on L2 PCB is not locked. | |
| 304 | L3 PLL 36M NOT LOCKED | PLL on L3 PCB is not locked. | |
| 305 | LOW RF (REC HEAD) | Envelope level has dropped from the recording head during playback. | Check the flying erase system circuit. |

| No. | Message | Error description | Remedial action |
|-----|---|--|---|
| 400 | FAN STOP 1 FAN STOP 2 | F1 fan (on the power supply side) has stopped. F2 fan (opposite the power supply side) has stopped. | The fan continues to operate for a while but the internal temperature rises and the power is switched off. Set the power switch to OFF as soon as possible, and consult with your dealer. A warning appears. Set the power switch to OFF as soon as possible, and consult with your dealer. |
| 403 | CRC ERROR IN SERIAL DIGITAL INPUT | CRC error has been detected from video signals among HD serial input signals. | SDI_IN lamp flashes: Check the input signals. |
| 404 | NO DIGITAL VIDEO INPUT | Video signals cannot be detected among HD serial input signals. | Check the input signals. |
| 405 | NO EMBEDDED AUDIO INPUT | Audio signals cannot be detected among HD serial input signals. | Check the input signals. |
| 406 | AUDIO DATA ERROR IN SERIAL DIGITAL INPUT | Power transmission error has been detected from audio signals among HD serial input signals. | Check the input signals. |
| 410 | NO EXTERNAL REF | The reference signal is not supplied to the HD REF input connector. | Check the reference signal. |
| 412 | DIGITAL VIDEO INPUT NOT LOCKED TO EXT_REF | Field frequency of video input signals and field frequency of reference signal do not match. | Match the field frequencies of the video input signals and reference signal. |
| 413 | RECORDING FORMAT UMATCH | The HDD5 format was not used when the playback tape was recorded. | Check the recording format of the playback tape. |
| 415 | NO SERIAL LTC | LTC cannot be detected from HD serial input signals. | Check the serial input signals. |
| 416 | NO SERIAL VITC | VITC cannot be detected from HD serial input signals. | Check the serial input signals. |

AUTO OFF error messages

When trouble has occurred and the unit can no longer be operated or when the mechanisms or tape may be damaged by continued use of the unit in its present state, the AUTO OFF lamp and SYSTEM error lamp on the unit's front panel light, the buzzer sounds, and an error message appears on the screen. In cases like this, stop operating the unit and follow the instructions given.

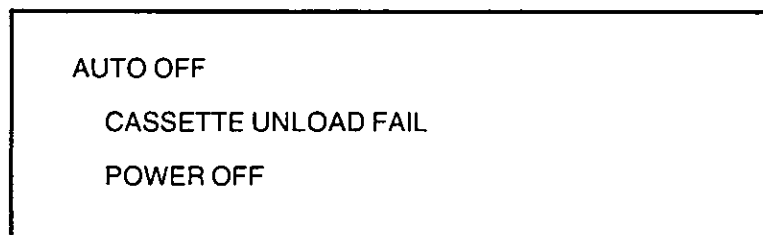
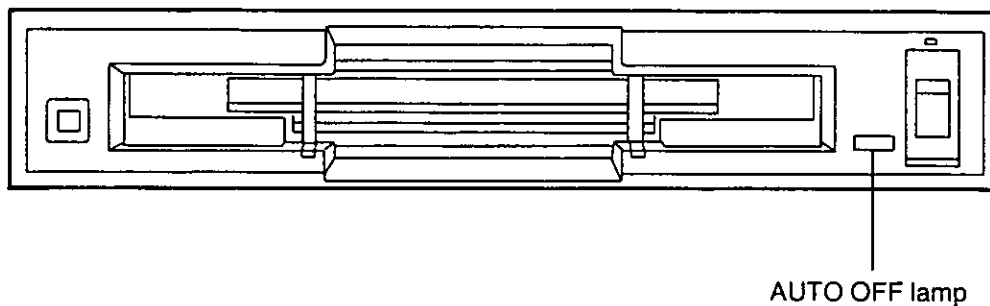

- Except when the DEW error message appears, the original screen will not be restored unless the power is first switched off and then turned back on again.

AUTO OFF occurs mainly when there is an error in the tape transport system. When AUTO OFF has occurred, first open the unit's top panel and check that the tape used is properly installed in the transport system, and then turn on the power. If the tape used has slipped out, contact the dealer from whom you purchased the unit.

ERROR messages

| No. | Message | Error description | VTR operation and remedial action |
|------|--|--|--|
| 201 | CASSETTE UNLOAD FAIL | The cassette fails to unload even after 5 seconds have elapsed since the operation mode was transferred to cassette unloading. | The motor stops running. Turn the power off and then back on again. |
| 203 | SUB UNLACING FAIL | The sub unloading operation is not completed within 10 seconds. | The motor stops running. Turn the power off and then back on again. |
| 205 | MAIN UNLACING FAIL | The main unloading operation is not completed within 10 seconds. | The motor stops running. Turn the power off and then back on again. |
| 206 | CASSETTE PHOTO SENSOR TROUBLE | Trouble with an LED, etc. has been detected. | The motor stops running, and the unit is placed in the STOP mode. |
| 206A | DETECTION SWITCH FALL (A) (No. 206) | Switch (A) (cylinder side) has failed. | Check switch (A). |
| 206B | DETECTION SWITCH FALL (B) (No. 206) | Switch (B) (center) has failed. | Check switch (B). |
| 206C | DETECTION SWITCH FALL (C) (No. 206) | Switch (C) (cassette loading side) has failed. | Check switch (C). |
| 207 | DEW | Condensation has formed inside the unit. | The cassette is ejected. Do not turn off the power but keep the unit in its present state. The drum rotates and the condensation is removed. Once the condensation has been removed, the message is cleared and normal operation can be resumed. |
| 251 | ROTATE-RANGE OVER | Trouble with the drum rotation has lasted for more than 5 seconds. | The motor stops running. Turn the power off and then back on again. |
| 252 | CAPSTAN NOT ROTATE | Trouble with the capstan rotation has lasted for more than 2 seconds. | The motor stops running. Turn the power off and then back on again. |

| No. | Message | Error description | VTR operation and remedial action |
|-----|---------------------------------|--|---|
| 253 | TAPE TENSION ERROR | Trouble with tape tension has been detected for about 1 second. | The motor stops running. Turn the power off and then back on again. |
| 258 | TAPE TENSION OVER-RANGE IN SHTL | Tension trouble has lasted for more than about 1 second in the shuttle (reel) mode. | The motor stops running. Turn the power off and then back on again. |
| 259 | REEL DIRECTION UNMATCH | The take-up reel and supply reel are rotating in different directions. | The motor stops running. Check the tape transport system. |
| 260 | WIND-UP REEL NOT ROTATE | The take-up reel fails to rotate even though the tape has traveled by the capstan for 1 5/8" (4 cm). | The motor stops running. Turn the power off and then back on again. |
| 263 | CPU (SYS) TAPE HANDLE TROUBLE | Syscon microcomputer processing has overflowed. | Check the 9P input, video inputs and L2 REC PCB. |
| 267 | NO S-REEL FG PULSE | The supply reel motor fails to run. (FG pulses are not detected.) | The motor stops running. Turn the power off and then back on again. |
| 268 | NO T-REEL FG PULSE | The take-up reel motor fails to run. (FG pulses are not detected.) | The motor stops running. Turn the power off and then back on again. |

SYSTEM error messages

When trouble has occurred and the unit's operations can no longer be guaranteed, the SYSTEM error lamp on the unit's front panel lights, the buzzer sounds, and an error message appears on the screen.

In a case like this, stop operating the unit immediately and follow the instructions given to remedy the problem.

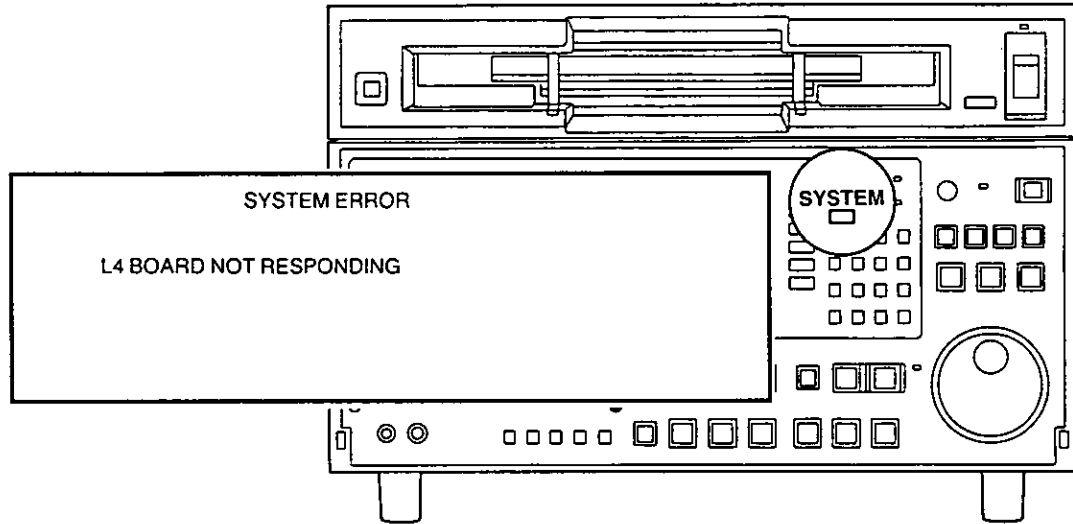

- When the cause of the system error is removed, the original screen can be restored.

ERROR messages

| No. | Message | Error description | VTR operation and remedial action |
|-----|---|---|--|
| 100 | L1 BOARD NOT RESPONDING | L1 circuit board is disengaged. | Insert the L1 circuit board into its proper place. |
| 101 | L2 BOARD NOT RESPONDING | L2 circuit board is disengaged. | Insert the L2 circuit board into its proper place. |
| 102 | L3 BOARD NOT RESPONDING | L3 circuit board is disengaged. | Insert the L3 circuit board into its proper place. |
| 103 | L4 BOARD NOT RESPONDING | L4 circuit board is disengaged. | Insert the L4 circuit board into its proper place. |
| 104 | S4 BOARD NOT RESPONDING | S4 circuit board is disengaged. | Insert the S4 circuit board into its proper place. |
| 109 | S6 BOARD NOT RESPONDING | S6 circuit board is disengaged. | Insert the S6 circuit board into its proper place. |
| 110 | REMOTE JACK2 BOARD NOT ATTACHED REMOTE | JACK2 circuit board is disengaged. | Insert the REMOTE JACK2 circuit board into its proper place. |
| 111 | S3 BOARD NOT RESPONDING | S3 circuit board is disengaged. | Insert the S3 circuit board into its proper place. |
| 112 | S7 BOARD NOT RESPONDING | S7 circuit board is disengaged. | Insert the S7 circuit board into its proper place. |
| 113 | S10 BOARD NOT RESPONDING | S10 circuit board is disengaged. | Insert the S10 circuit board into its proper place. |
| 114 | S11 BOARD NOT RESPONDING | S11 circuit board is disengaged. | Insert the S11 circuit board into its proper place. |
| 131 | FRONT PANEL NOT RESPONDING | No communication response from the front panel to the syscon. | Check the front panel cables, control switches and front panel itself. |
| 132 | RECEIVED INVALID COMMAND FROM FRONT PANEL | An undefined command has been received from the front panel. | Check the front panel cables, control switches and front panel itself. |

| No. | Message | Error description | VTR operation and remedial action |
|-----|--------------------------------------|--|--|
| 133 | SYSCON NOT RESPONDING | No communication response from the syscon. | Check the front panel cables, control switches and front panel itself. |
| 134 | RECEIVED INVALID COMMAND FROM SYSCON | An undefined command has been received from the syscon. | Check the front panel cables, control switches and front panel itself. |
| 200 | CASSETTE LOAD FAIL | Cassette fails to load even when 4 seconds have elapsed since it was inserted. | Cassette is ejected. Insert the cassette again. |
| 202 | SUB LACING FAIL | Sub loading operation is not completed within 10 seconds. | Cassette is ejected. Insert the cassette again. |
| 204 | MAIN LACING FAIL | Main loading operation is not completed within 10 seconds. | Cassette is ejected. Insert the cassette again. |
| 208 | HUB POSITION | Reel base position does not match the cassette size. | Cassette is ejected. Insert the cassette again. |
| 256 | T-REEL DRIVE OVER RANGE | Trouble in take-up reel rotation continues for more than 0.5 sec. | If normal operation is not restored, the unit is place in the AUTO OFF mode. |
| 257 | S-REEL DRIVE OVER RANGE | Trouble in supply reel rotation continues for more than 0.5 sec. | If normal operation is not restored, the unit is place in the AUTO OFF mode. |

OPERATION messages

Mainly when the wrong button or key has been operated during automatic editing, operation guidance messages appear at the bottom right of the screen (above the tape speed display).

- The message display is cleared automatically after several seconds.

The image shows a control panel interface for a video editing system. It features a central display area with various indicators and controls, surrounded by function buttons labeled F1 through F13.

Central Display Area:

- Top Left:** A vertical scale from 0 to -40, with markers at 0, -4, -8, -12, -16, -20, -25, -30, -40, and -∞. Below the scale are buttons labeled LR, LP, LR, LR, LR, and a row of AES buttons.
- Top Center:** A section labeled « AUTO EDIT » with a double arrow icon. Below it are fields for IN and OUT times, and a vertical stack of buttons: 1000, HD 59, 1000 59, CH0, CMPST, SQUEEZE, and VID IN.
- Top Right:** A section labeled CUT with a vertical stack of buttons: CH SELECT, MANUAL EDIT, SPOT ERASE, SPLIT, INSEFT, and SET UP.
- Middle:** A section labeled RECORDER with a digital display showing 00:00:00:00. Below it are buttons for VIDEO, CH1, CH2, CH3, CH4, CUE, and TC.
- Bottom:** A row of buttons labeled LAST X, LAST ED, W/PLYR, VAR MEMO, PLYR SEL, R/P SEL, and TRIM. Below these are several OFF buttons and a button labeled PLYR-1 RECORDER.

Function Buttons:

- Bottom Row:** F1, F2, F3, F4, F5, F6, F7, F8
- Right Column:** F13, F12, F11, F10, F9

Messages (in AUTO EDIT MODE)

| No. | Message | Error description |
|-----|----------------------|--|
| 350 | NO CASSETTE | The cassette tape has not been inserted. |
| 351 | NO PRESET | The editing mode or edit channel for insert editing has not been selected. |
| 352 | NO IN POINT | The edit point data required for editing has not been entered. |
| 353 | NO PLY'R MODE | A mode has not been established in which the player can be controlled. Set the mode properly on the INSERT/ASSEMBLE AUTO EDIT menu. |
| 354 | NOT REC'R MODE | A mode has not been established in which the recorder can be controlled. Set the mode properly on the INSERT/ASSEMBLE AUTO EDIT menu. |
| 355 | NEGATIVE DURATION | The time data of the edit OUT point is ahead of the time data of the edit IN point. |
| 356 | INVALID DATA | Illogical or invalid data has been input. |
| 357 | PLAYER LOCAL | The connected player is in the LOCAL mode. |
| 359 | REC INHIBITED | An attempt has been made to execute auto editing when the recording inhibit mode has been set. Set the key on the HOME menu and operate the recording inhibit pin on the cassette tape to release the REC INHIBIT mode. |
| 360 | W/PLAYER NOT SET | A mode has not been established in which the player can be operated. Check the setting of the F1 (MODE) key on the INSERT/ASSEMBLE AUTO EDIT SET UP menu. |
| 361 | BOT | Beginning of tape. |
| 362 | EOT | End of tape. |
| 363 | SHIFT TC FOR CF EDIT | The time code in the CF lock mode does not have an appropriate value. |

Internal switches

The functions listed below can be set using the switches on the circuit boards inside the unit.

- All switches not described below are for factory adjustments, and their settings should not be changed. Any change will disable proper operation of the unit.

The L1 to L4 circuit boards can be accessed when the front panel is opened.

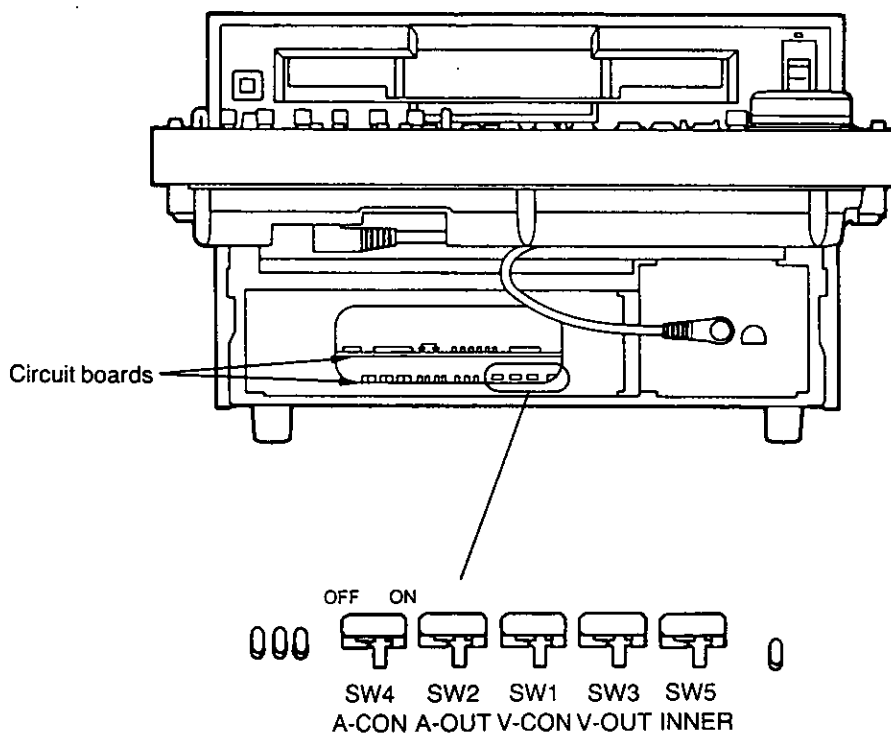

□ L4 circuit board

| Switch | Function |
|--------|--|
| SW1 | ON: Video signal modification ON OFF: Video signal modification OFF |
| SW2 | ON: Audio outer error correction ON OFF: Audio outer error correction OFF |
| SW3 | ON: Video outer error correction ON OFF: Video outer error correction OFF |
| SW4 | ON: Audio signal modification ON OFF: Audio signal modification OFF |
| SW5 | ON: Inner error correction ON OFF: Inner error correction OFF |

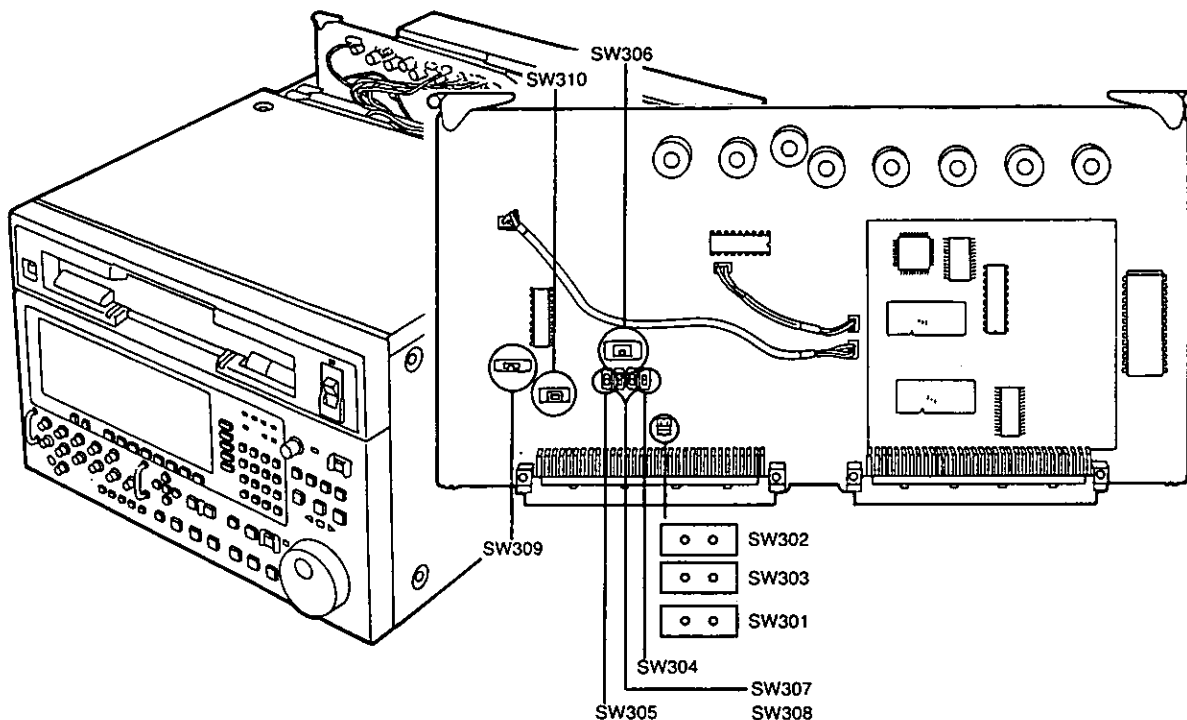

| Circuit board | Switch | Function | | | | | | | | | | | | | | | | |
|-----------------|-------------------------|--|-----------------|-------|-------|-------|------|------|------|-------|------|------|-------|------|------|-------|------|------|
| S3 | SW301 SW302 SW303 | These select the audio input impedance. <table border="1" style="margin-left: 20px;"> <thead> <tr> <th>Switch Position</th> <th>SW301</th> <th>SW302</th> <th>SW303</th> </tr> </thead> <tbody> <tr> <td>HIGH</td> <td>Open</td> <td>Open</td> <td>Short</td> </tr> <tr> <td>600Ω</td> <td>Open</td> <td>Short</td> <td>Open</td> </tr> <tr> <td>150Ω</td> <td>Short</td> <td>Open</td> <td>Open</td> </tr> </tbody> </table> | Switch Position | SW301 | SW302 | SW303 | HIGH | Open | Open | Short | 600Ω | Open | Short | Open | 150Ω | Short | Open | Open |
| Switch Position | SW301 | SW302 | SW303 | | | | | | | | | | | | | | | |
| HIGH | Open | Open | Short | | | | | | | | | | | | | | | |
| 600Ω | Open | Short | Open | | | | | | | | | | | | | | | |
| 150Ω | Short | Open | Open | | | | | | | | | | | | | | | |
| | SW304 SW305 | These switch between the microphone and line. MIC/LINE (Note) If MIC is selected when SW306 has been set to a level of -20 dBm, the input will have a -60 dBm level. | | | | | | | | | | | | | | | | |
| | SW306 | This selects the audio input level. +4/0/-20 dBm | | | | | | | | | | | | | | | | |
| | SW307 SW308 | These can select +4 or +8 dBm when SW306 has been set to +4 dBm. | | | | | | | | | | | | | | | | |
| | SW309 | This selects the audio output level. +4/0/-20 dBm | | | | | | | | | | | | | | | | |
| | SW310 | This can select +4 or +8 dBm when SW309 has been set to +4 dBm. | | | | | | | | | | | | | | | | |

Using the optional board AJ-MK30

This board is mounted on the 1/2 inch digital HD VTR (AJ-HD2700), and is an option board which achieves audio analog input and output.

The AJ-HD2700 gains the following functions when this board is used.

- Audio analog input
- Audio analog output
- Audio monitor output

Board installation

1. After turning off the power source for the main unit (AJ-HD2700), open the top panel and remove the metal holder for the S board.
2. Insert the AJ-MK30 (S8 and S9 boards) as shown in the figure below.

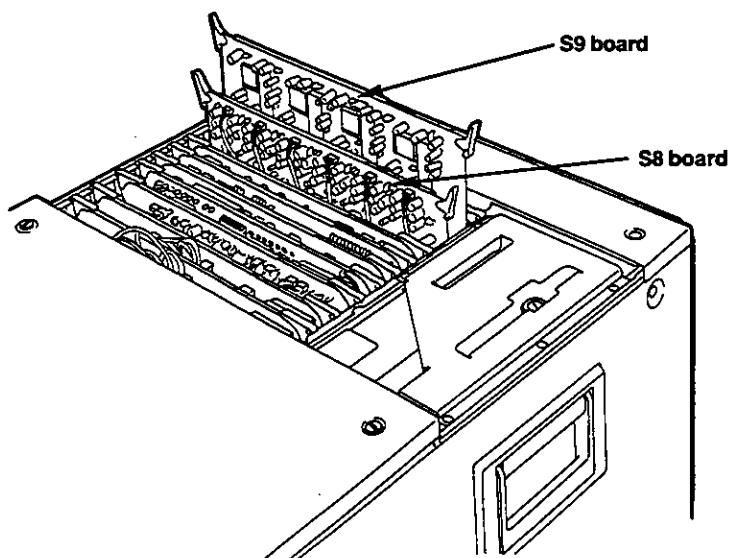

3. After inserting the AJ-MK30, attach the metal holder for the S board and return the unit to its original state.

Using the Down-Converter Board AJ-DFC2000

When it is installed in a digital video cassette recorder (AJ-HD2700), this board is designed to convert Hi-Vision playback signals into 525 line system standard television signals and to output serial digital signals and NTSC analog signals.

By installing this board, the operation menus relating to the down-converter are automatically added on the front panel of the AJ-HD2700.

For details on the menu operations, refer to the DOWN CONV SET UP menu on page 69.

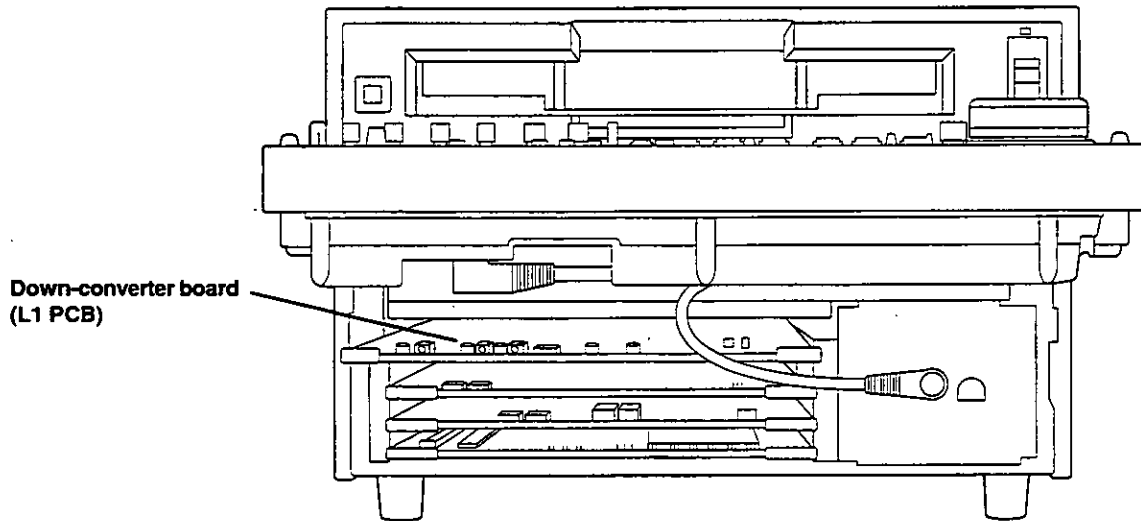

Installation procedure

1. After switching off the power of the VTR (AJ-HD2700), lift the front panel, and disengage the clamp provided to hold the boards in place.
2. Install the down-converter board (AJ-DFC2000).
3. Attach the clamp which was disengaged in step 1.
4. Take out the S PCB clamp and remove the S5 PCB.
5. Set SW1-1 on the S5 PCB to the ON position.

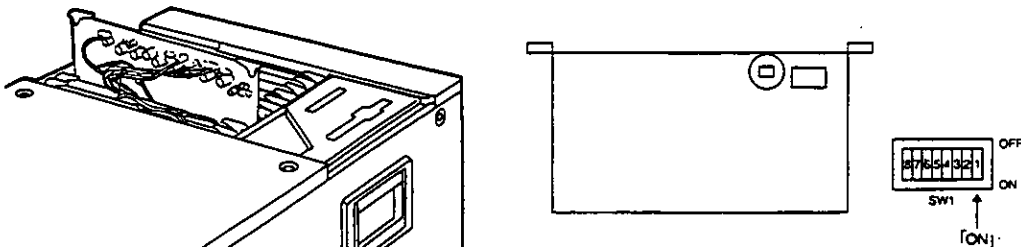

6. Return the S5 PCB to its original position and mount the S PCB clamp.

The clamp which is mounted on the inside of the board's front panel is designed to prevent the circuit board from popping out. When the board is to be transported, the two screws must be used to secure the clamp on both sides.

Remote control

The panel can be removed when operating the unit by remote control.

1. Press the PUSH button, and pull up the bottom of the front panel by 90° so that the panel will be horizontal.

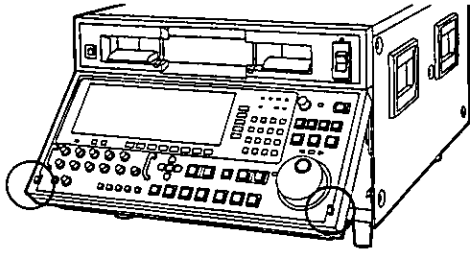

5. The control panel can be connected to the CONTROL PANEL connector on the unit's rear panel.

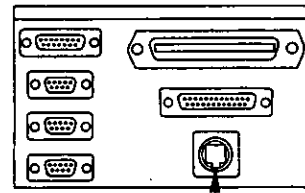

CONTROL PANEL connector

2. Loosen the screws.

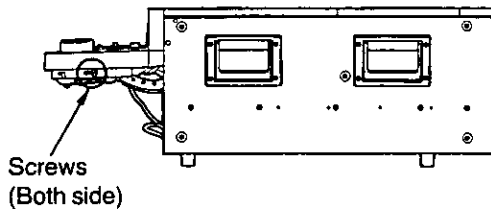

6. Set the switch inside the front panel to REAR. When it is set to REAR, the red lamp lights. When it is set to FRONT, operations cannot be conducted from the rear panel connector.

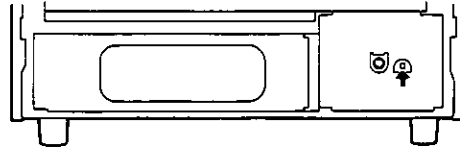

3. Disconnect the connecting cable.

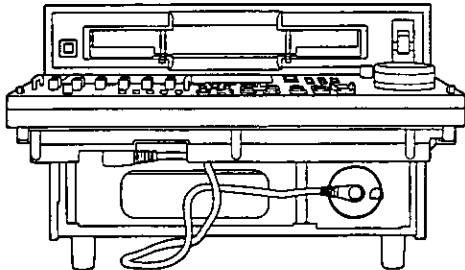

4. Detach the panel.
This can be done by drawing it flat out toward the rear and then lifting it straight up.

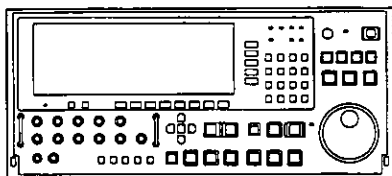

Screen life-saving function

This function is designed to extend the service life of the unit's large display screen. Keeping any of the menu screens displayed without any movement for a prolonged period of time may reduce the service life of the display screen. For this reason, a menu screen which has been displayed for over 5 minutes without any movement will be automatically replaced by the life-saving screen shown below.



The logo displayed moves on the screen.

Notes:

- The screen life-saving function is activated only when an absolutely movement-free menu screen has been displayed continuously for over 5 minutes.
When a function key is pressed at some point, the function will not be activated until 5 minutes have passed since that key was pressed.
- The function will not be activated even when only the time code value on a menu screen has been changed because the unit is in the recording, playback, etc. mode.

Video head cleaning

Although this unit comes with an auto head cleaning function which reduces the amount of dirt on the heads, it is recommended that the video heads be cleaned every day for even more dependable operation. (For further details, please consult with your local dealer.)

Operation

Soak some alcohol in a cleaning cloth, press it lightly against the middle drum as shown in the figure, and rotate the drum 2 or 3 times in the direction indicated by the arrow. After this, wipe the drum dry using a dry cleaning cloth.

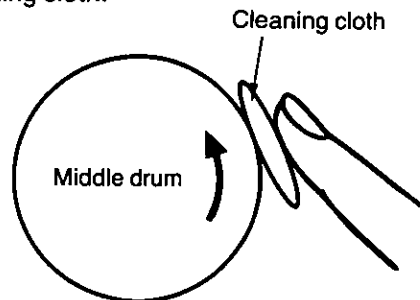

- Make sure that the power is off before proceeding with the head cleaning.
- Do not move your fingers up and down while cleaning.
This may damage the heads.
- Cut the cleaning cloth to the right size of the use.
- Proceed with the cleaning until no more dirt is taken up by the cleaning cloth.
- Make absolutely sure that no fluff from the cleaning cloth remains inside the VTR.
- When grease (from the VTR) is found to adhere to the cleaning cloth, be absolutely sure to replace the cleaning cloth.
- Before using the optional digital VTR dedicated head cleaning tape (AJ-TDCLS-P) to clean the heads, be sure to read carefully the "Precautions" provided with the cleaning tape.
- In addition to cleaning the video heads every day, make it a rule once a week to clean the tape transport system and once a month to clean the reel bases and carriage (cassette holder, front guide angles). For further details, please consult with your local dealer.

Maintenance

Before proceeding with maintenance, set the power switch to "OFF", and be sure to take hold of the power plug (and not the cord) to disconnect it from the power outlet.

Clean the cabinet with a soft cloth. With stubborn dirt, dilute some neutral kitchen detergent, dip the cloth in it, wring it out well and wipe the surface. After the dirt has been wiped off, take up any remaining moisture using a dry cloth. Under no circumstances must paint thinners or benzene be used for cleaning purposes.

Storage

- Do not store the unit in an extremely hot or cold location.
- The unit must never be left outdoors.
- If the unit is not going to be used for a long time, set the power switch to OFF and be sure to take hold of the power plug (and not the cord) to disconnect it from the power outlet. This step is taken to safeguard against accidents.
- Be sure to eject the cassette tape.

Connector signals

VIDEO IN

| | |
|---------------------|---|
| SERIAL IN (DIGITAL) | BNC×1 |
| HD REF IN | BNC×2, loop-through with 75Ω termination switch |
| NTSC REF IN | BNC×1 |

VIDEO OUT

| | |
|---------------------------------|-----------------------------|
| HD/SERIAL OUT (DIGITAL) | BNC×2 |
| HD/SERIAL MONITOR OUT (DIGITAL) | BNC×1 |
| DOWN CONVERTER/VIDEO (ANALOG) | BNC×3 |
| DOWN CONVERTER/SERIAL OUT | BNC×2 |
| SYNC OUT | BNC×1, 4 V(p-p) |
| 525 SYNC OUT | BNC×1 |
| WFM | BNC×1, Waveform output, 75Ω |

TIME CODE

| | |
|---------------|-------|
| TIME CODE IN | XLR×1 |
| TIME CODE OUT | XLR×1 |

AUDIO IN

| | |
|--------------------|------------------------------------|
| AUDIO IN (DIGITAL) | BNC×2 CH1/2, CH3/4, AES/EBU format |
| AUDIO IN (ANALOG) | XLR×4 CH1, CH2, CH3, CH4 |
| CUE IN | XLR×1 |

AUDIO OUT

| | |
|---------------------|--|
| AUDIO OUT (DIGITAL) | [(BNC×2)×2] CH1/2, CH3/4, AES/EBU format |
| AUDIO OUT (ANALOG) | XLR×4 CH1, CH2, CH3, CH4 |
| CUE OUT | XLR×1 |
| MONITOR | XLR×2 |
| HEADPHONES (FRONT) | 1/4" phone/6 mm |

Connector signals (Continued)

□ PARALLEL I/O (50P) connector

- (1) **PULSE SIGNAL:** The signal fall is detected, and the signal is made active.
 (2) **STATE SIGNAL:** The low section of the signal is detected, and the signal is made active.

| Pin No. | Signal name | Signal direction | Signal type | Description |
|---------|---------------|------------------|--------------|--|
| 1 | REC COMMAND | INPUT | PULSE SIGNAL | This transfers operation to the REC PLAY mode when it is made active simultaneously with the PLAY COMMAND signal. However, operation is not transferred to the REC mode when the insert or assemble mode has been set. |
| 2 | PLAY COMMAND | INPUT | PULSE SIGNAL | This transfers operation to the PLAY mode. |
| 3 | FF COMMAND | INPUT | PULSE SIGNAL | This transfers operation to the FF mode. |
| 4 | REW COMMAND | INPUT | PULSE SIGNAL | This transfers operation to the REW mode. |
| 5 | STOP COMMAND | INPUT | PULSE SIGNAL | This transfers operation to the STOP mode. |
| 6 | FIELD RATE | INPUT | STATE SIGNAL | High: 60 Hz; low: 59.94 Hz |
| 7 | MA1 COMMAND | INPUT | PULSE SIGNAL | When one of these signals is made active during EDIT PLAY, the mode transfer operation is "toggled" as indicated below. PCM AUDIO REC ↔ PCM AUDIO REC release Conditions for executing operation 1. F10 (MAN AUDIO) on the SETUP INTERFACE menu must be ON. 2. Operation is executed regardless of whether the REMOTE or LOCAL mode is established. 3. INS must be set. 4. The sequence of priority for the front, 9P (RS-422) and 50P PCM AUDIO REC setting/release follows the input sequence. |
| 8 | MA2 COMMAND | INPUT | PULSE SIGNAL | |
| 9 | MA3 COMMAND | INPUT | PULSE SIGNAL | |
| 10 | MA4 COMMAND | INPUT | PULSE SIGNAL | |
| 11 | EJECT COMMAND | INPUT | PULSE SIGNAL | This transfers operation to the EJECT mode. |
| 12 | IN COMMAND | INPUT | PULSE SIGNAL | When this signal is made active, the current time (TC, CTL) on the VTR is registered on one of the menus listed below. When the VTR has the HOME menu opened: ●The time is registered in CUE TIME on the HOME menu. When the VTR has the AUTO EDIT menu opened: ●The time is registered in CUE TIME on the HOME menu. ●The time is registered in the IN point on the AUTO EDIT menu. When the VTR has the EXTEND MULTI CUE menu opened: ●The time is registered at the cursor position on the EXTEND MULTI CUE menu. When the VTR has the MULTI CUE menu opened: ●The time is not registered on any menu. When the VTR has a menu opened other than the ones above: ●The time is registered in CUE TIME on the HOME menu. |
| 13 | SYSTEM REMOTE | INPUT | STATE SIGNAL | This sets whether the 50P parallel input is to be accepted or not. High: Input is not accepted. Low: Input is accepted. |
| 14 | — | | | |
| 15 | | INPUT | | |
| 16 | | INPUT | | |

| Pin No. | Signal name | Signal direction | Signal type | Description |
|---------|----------------------|------------------|--------------|--|
| 17 | DOWN_CONVERT_H LEFT | INPUT | STATE SIGNAL | High: NO_CHANGE. Low: The cutoff frame of the DOWN_CON output in the horizontal direction is continuously moved to the left. |
| 18 | DOWN_CONVERT_H RIGHT | INPUT | STATE SIGNAL | High: NO_CHANGE. Low: The cutoff frame of the DOWN_CON output in the horizontal direction is continuously moved to the right. |
| 19 | DOWN_CONVERT UNITY | INPUT | PULSE SIGNAL | The DOWN_CON cutoff frame is moved to the center (UNITY position); UNITY position ↔ VAR position. |
| 20 | STBY COMMAND | INPUT | PULSE SIGNAL | This "toggles" setting as shown below. It functions only in the STOP or STANDBY OFF mode. STANDBY ON ↔ STANDBY OFF |
| 21 | ERR 0 STATUS | OUTPUT | | Refer to the 50P error status output table shown below (this signal is tied in with pins 24 and 34). |
| 22 | | INPUT | | |
| 23 | CUE COMMAND | INPUT | PULSE SIGNAL | When this signal is made active, the tape is prerolled from the CUE UP point on the VTR's menu. When the VTR has the AUTO EDIT menu opened: •The tape is prerolled from the IN point time when the AUTO EDIT menu IN point has been registered. •The tape is prerolled from the current position time when the AUTO EDIT menu IN point has not been registered. When the VTR has a menu opened other than the one above: •The tape is prerolled from the CUE TIME time when the HOME menu CUE TIME has been registered. The tape is prerolled from the current position time when the HOME menu CUE TIME has not been registered. |
| 24 | ERR 1 STATUS | OUTPUT | | Refer to the 50P error status output table shown below (this signal is tied in with pins 21 and 34). |
| 25 | — | | | |
| 26 | +12 V power | OUTPUT | | |
| 27 | REC STATUS | OUTPUT | ACTIVE_L | This signal is made active in the REC mode. It is also made active when the REC button on the front panel is lighted. |
| 28 | PLAY STATUS | OUTPUT | ACTIVE_L | This signal is made active in the PLAY mode. It is also made active when the PLAY button on the front panel is lighted. |

•50P error status out table

| Output priority sequence | Pin 21/ERR 0 | Pin 24/ERR 1 | Pin 34/ERR 2 | VTR status |
|--------------------------|--------------|--------------|--------------|---------------|
| 1 | 0 | 0 | 0 | NO SERVO LOCK |
| 6 | 0 | 0 | 1 | SERVO LOCK |
| 5 | 0 | 1 | 0 | HIGH ERROR |
| 4 | 0 | 1 | 1 | CONCEALV |
| 3 | 1 | 0 | 0 | CONCEAL/A |
| 2 | 1 | 0 | 1 | CONCEAL/VA |
| — | 1 | 1 | 0 | |
| — | 1 | 1 | 1 | |

Connector signals (Continued)

| Pin No. | Signal name | Signal direction | Signal status (open collector) | Description |
|---------|----------------------|------------------|--------------------------------|---|
| 29 | FF STATUS | OUTPUT | ACTIVE_L | This signal is made active in the FF mode. |
| 30 | REW STATUS | OUTPUT | ACTIVE_L | This signal is made active in the REW mode. |
| 31 | STOP STATUS | OUTPUT | ACTIVE_L | This signal is made active in the STOP mode. |
| 32 | FIELD RATE STATUS | OUTPUT | | High: 60 Hz; low: 59.94 Hz |
| 33 | EJECT STATUS | OUTPUT | ACTIVE_L | This signal is made active when the cassette tape has not been inserted. |
| 34 | ERR 2 STATUS | OUTPUT | ACTIVE_L | Refer to the 50P error status output table (this signal is tied in with pins 21 and 24). |
| 35 | AEI 1 STATUS | OUTPUT | ACTIVE_L | This signal is made active when PCM AUDIO CH1 is in the recording status. |
| 36 | AEI 2 STATUS | OUTPUT | ACTIVE_L | This signal is made active when PCM AUDIO CH2 is in the recording status. |
| 37 | AEI 3 STATUS | OUTPUT | ACTIVE_L | This signal is made active when PCM AUDIO CH3 is in the recording status. |
| 38 | AEI 4 STATUS | OUTPUT | ACTIVE_L | This signal is made active when PCM AUDIO CH4 is in the recording status. |
| 39 | SYSTEM REMOTE STATUS | OUTPUT | | This sets whether the 50P parallel input (6, 17, 18 and 19 pins) is to be accepted or not. High: Input is not accepted. Low: Input is accepted. |
| 40 | VER STATUS | OUTPUT | ACTIVE_L | This signal is made active between the IN and OUT points selected by VIDEO in the PREVIEW mode and when video recording has been performed with the insert or assemble setting. It is not made active during assemble PREVIEW initiated from the controller (the STOP status is established when the VTR tape has passed the IN point). |
| 41 | CUE STATUS | OUTPUT | ACTIVE_L | This signal is made active when the PREROLL or CUE UP operation is completed. The active status is released when operation is transferred from the STBY ON/OFF operation to any other operation. |
| 42 | REMOTE STATUS | OUTPUT | ACTIVE_L | This signal is made active when the VTR is in the REMOTE status. |
| 43 | DOWN_CONVERT STATUS | OUTPUT | | High: VAR (the cutoff position is off-center); low: UNITY (the cutoff position is at the center) |
| 44-45 | | OUTPUT | | |
| 46 | STBY STATUS | OUTPUT | ACTIVE_L | This signal is made active when the STBY ON status has been established in the STOP mode. ACTIVE flashes (at 2-second intervals) starting 30 seconds before operation is transferred to the loosing mode. It flashes (at half-second intervals) starting 10 seconds before operation is transferred to the STBY OFF mode. |
| 47 | GND | OUTPUT | | |
| 48 | AER STATUS | OUTPUT | ACTIVE_L | This signal is made active between the IN and OUT points selected by AUDIO in the PREVIEW mode and when audio recording has been performed with the insert or assemble setting. It is not made active during assemble PREVIEW initiated from the controller (the STOP status is established when the VTR tape has passed the IN point). |
| 49-50 | GND | OUTPUT | | |

RS-422A REMOTE

| Pin No. | Signal | Pin No. | Signal |
|---------|--|---------|--|
| 1 | FRAME GROUND | 6 | GND |
| 2 | REM IN (-) LINE (-) | 7 | REM IN (-) CMD LINE (-) |
| 3 | REM OUT (-) STATUS LINE (+) | 8 | REM OUT (-) STATUS LINE (+) |
| 4 | GND | 9 | FRAME GROUND |
| 5 | — | | |

RS-232C REMOTE

| Pin No. | Signal | Pin No. | Signal |
|---------|--|---------|---|
| 1 | FRAME GROUND | 7 | GND Signal ground |
| 2 | TX Send data | 8 | DCR Receive carrier detect |
| 3 | RX Receive data | 9-19 | — |
| 4 | RTS Request to send | 20 | DTR Data terminal ready |
| 5 | CTS Clear to send | 21-25 | — |
| 6 | DSR Data set ready | | |

V/A CONTROL

| Pin No. | Signal | Pin No. | Signal |
|---------|--|---------|---|
| 1 | FRAME GROUND | 8 | REM TX (X) REMOTE CONTROL PROTOCOL TRANSMIT |
| 2 | | 9-13 | — |
| 3 | — | 14 | REM RX (Y) REMOTE CONTROL PROTOCOL RECEIVE |
| 4 | REM (G) | 15 | REM TX (Y) REMOTE CONTROL PROTOCOL TRANSMIT |
| 5-6 | — | | |
| 7 | REM RX (X) REMOTE CONTROL PROTOCOL RECEIVE | | |

Connector signals (Continued)

□ CONTROL PANEL

| Pin No. | Signal | Pin No. | Signal |
|---------|--------------------|---------|----------------------------|
| 1 | Headphone (L) | 11 | Headphone (GND) |
| 2 | Clock (+) | 12 | GND |
| 3 | RECEIVE DATA (+) | 13 | +24 V unregulated DC power |
| 4 | RECEIVE ENABLE (+) | 14 | RECEIVE STROBE (+) |
| 5 | TRANSMIT DATA (+) | 15 | TRANSMIT ENABLE (+) |
| 6 | Headphone (R) | 16 | DC control signal |
| 7 | Clock (-) | 17 | GND |
| 8 | RECEIVE DATA (-) | 18 | +24 V unregulated DC power |
| 9 | RECEIVE ENABLE (-) | 19 | RECEIVE STROBE (-) |
| 10 | TRANSMIT DATA (-) | 20 | TRANSMIT ENABLE (-) |

Installation

□ Dimensions

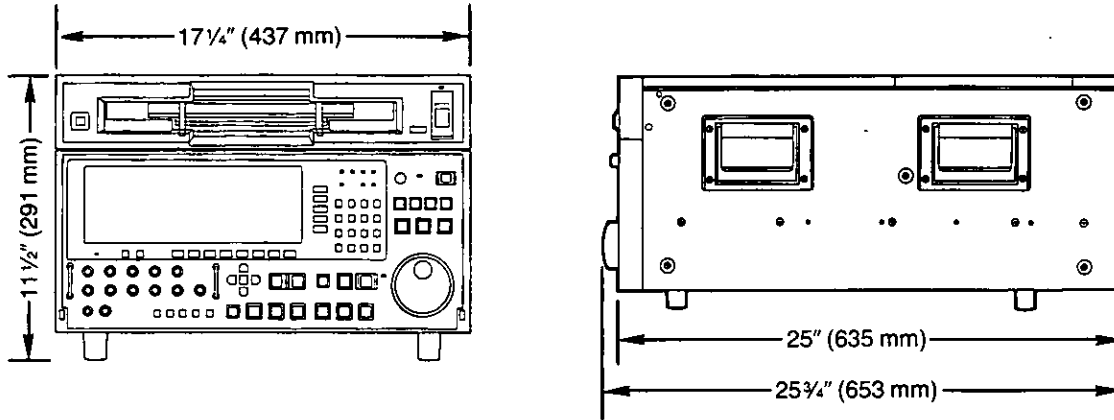

□ Installation

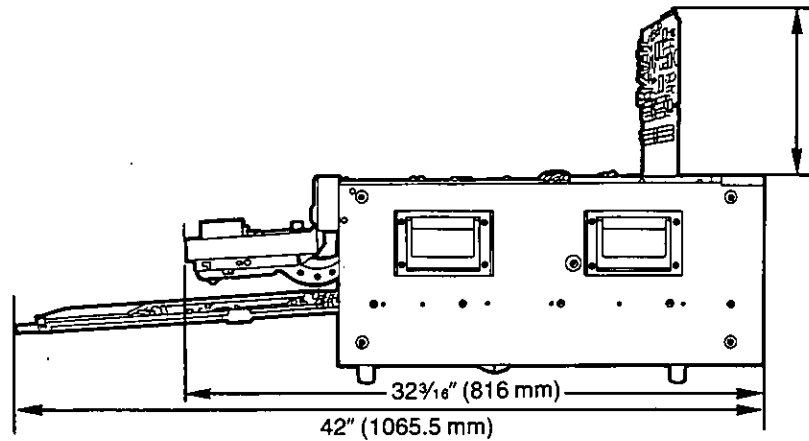

- Install the unit on a flat and stable foundation, and ensure that it is level.
- Do not obstruct the area around the unit's cooling fan. This may damage the inside of the unit.
- Keep the temperature of the installation environment to between +41°F (5°C) and 104°F (40°C). The unit may not operate properly or malfunctioning may develop at temperatures outside this range.
- Avoid installing the unit in the following locations.
 - Locations exposed to direct sunlight or powerful lights
 - Very dusty locations
 - Locations with strong electrical or magnetic fields
 - Locations susceptible to high levels of electrical or static noise

Rack-Mounting

The unit can be installed in EIA standard 19-inch rack if the AJ-MA35 rack-mounting adaptors (optional) are used.

It is recommended that the rail and bracket for 18" length (model number CC-3001-99-0191) of CHASSIS TRAK be used. (The complete slide rail and bracket unit is not available from Panasonic.) For further details, please consult with you dealer.

1. Remove the screws on the unit's left and right side panel.

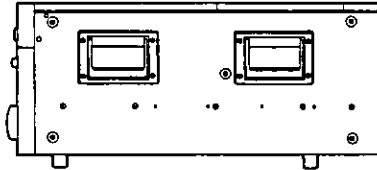

2. Use the screws which have been removed to attach the inner members of the slide rails.

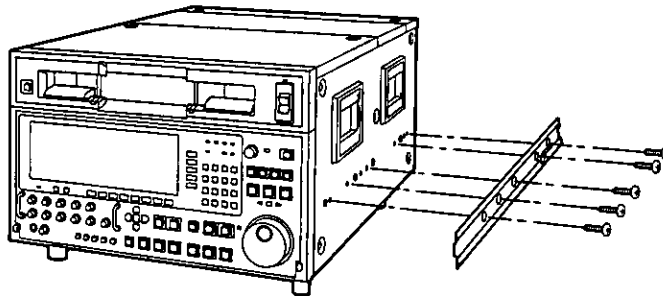

- The length of the screws used is restricted. If the mounting screws have been misplaced or lost, use screws (M4×10) which are less than 10 mm long.
- Be sure to secure the inner members in at least 5 places.

3. Remove the four set feet on the bottom of the unit.
4. Mount the outer member brackets on the rack.
 - Check that the brackets have been positioned at the same height on the left and right.
5. Attach the AJ-MA35 rack-mounting adaptors.

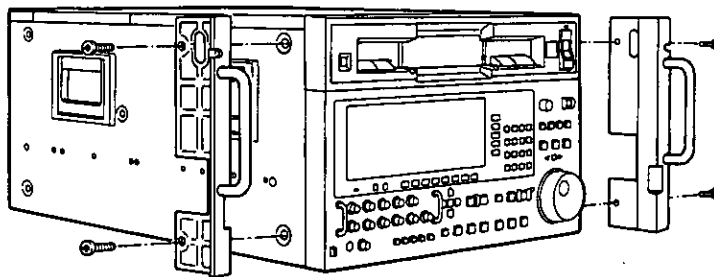

6. Install the unit in the rack.
 - Release the inner member stoppers when housing the VTR in the rack.
 - After having installed the unit, check that it can be moved smoothly along the rails, and fasten the adaptor to the rack with the screws.

- Keep the temperature inside the rack to between +41°F (5°C) and +104°F (+40°C).
- Bolt the rack securely to the floor so that it will not topple over when the VTR is drawn out.

Troubleshooting

| Symptom | Cause and remedy |
|--|--|
| Operation does not correspond to the mode selected on the menu screen. | Has the mode been changed on another menu? <ul style="list-style-type: none">• The mode selected last takes precedence.• REC inhibit takes precedence in the following sequence: CASSETTE, HOME and MANUAL/AUTO EDIT SET UP. This means that recording is not possible when the REC inhibit function has been applied to the cassette tape. |
| No operation results even when the function buttons are pressed. | <ul style="list-style-type: none">• Is the CONTROL switch at the "LOCAL" position? |
| No recording or editing: | <ul style="list-style-type: none">• Is the cassette pin at the recording enable position? |
| Stripes appear on part of the picture during playback. | <ul style="list-style-type: none">• Has the tracking been adjusted properly?• Adjust the tracking on the MANUAL EDIT SET UP or SERVO TEST menu. |

Table of MENU screen transitions

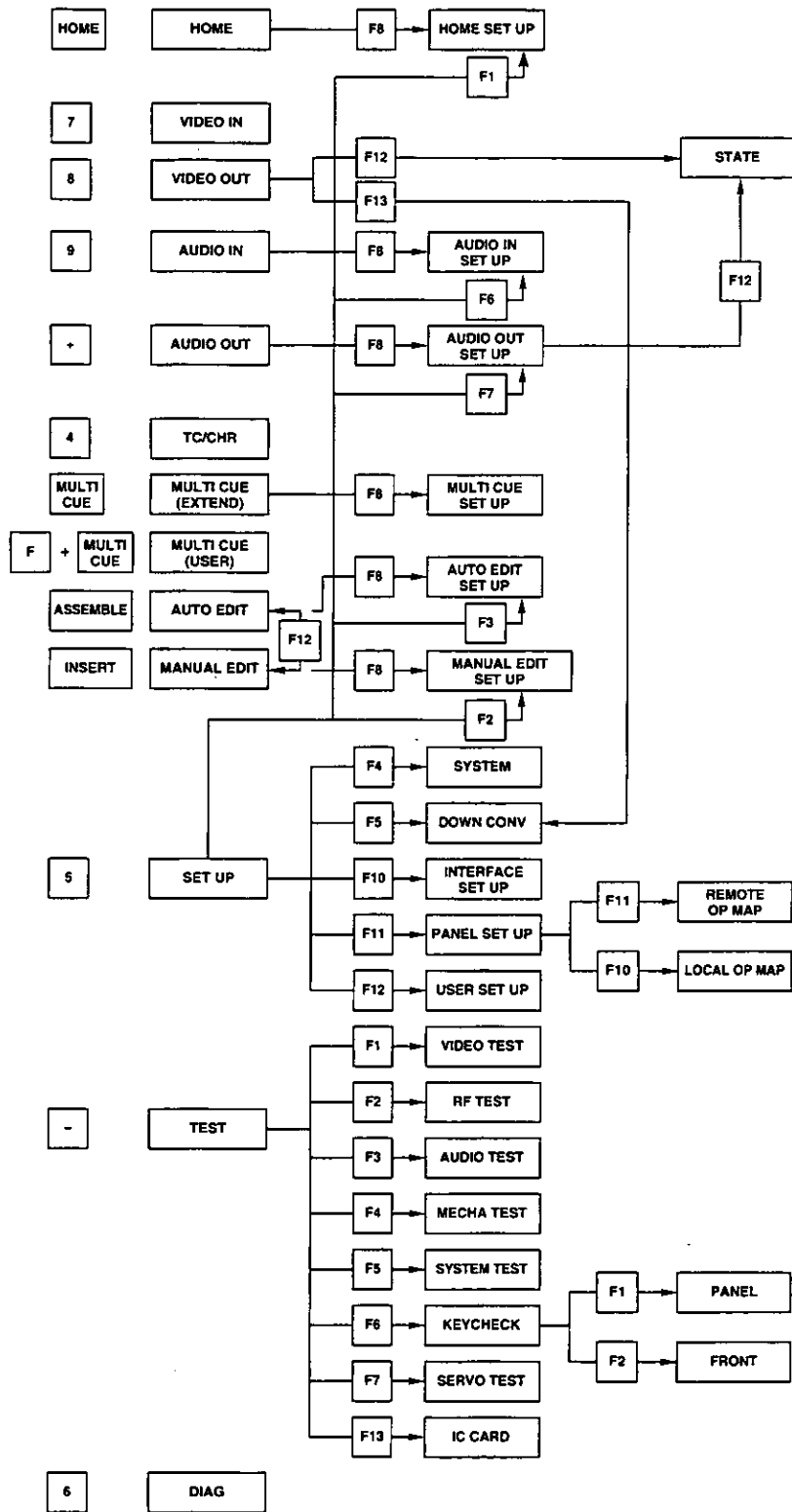

List of MENU screens

| FUNC key | Menu | | | | | | | | FUNC key |
|----------|---------------------------|---------------------------------|--------------|--|--------------|--|---------------------|---|----------|
| | HOME | | HOME SET UP | | VIDEO IN | | VIDEO OUT | | |
| | Setting item | Item selected | Setting item | Item selected | Setting item | Item selected | Setting item | Item selected | |
| F1 | OUTPUT | <u>TAPE</u> EE | SYNC PLY | ON <u>OFF</u> | VIDEO | <u>DIGITAL</u> INT SG | Y | | F1 |
| F2 | FREEZE | ON <u>OFF</u> | AT PLY | <u>FIELD</u> FRAME1 FRAME2 | | | P _B | | F2 |
| F3 | EJT CTL | <u>RESET</u> HOLD | PRG PLAY | <u>FINE</u> COARSE | | | P _R | <u>UNITY</u> VAR | F3 |
| F4 | TC/CTL | <u>TC</u> CTL1 CTL2 | PRG PLAY | Variable from ~ 15% to + 15% in steps set for F3 key | INT SG | <u>100% CB</u> 75% CB BLACK MULT-BST RAMP SIF PLL SIF EQ | BLACK. L | | F4 |
| F5 | TC/UB | <u>TC</u> UB | | | | | V PHASE | <u>UNITY</u> VAR | F5 |
| F6 | (CTL) CLR (TC) (UB) | | TAPE MD.. | <u>HD. STOP</u> HLF LOAD | | | | | F6 |
| F7 | TC HOLD | | | | | | SERIAL SYS PHASE | <u>UNITY</u> VAR | F7 |
| F8 | SET UP | Transfer to menu screen. | EXIT | | | | SET UP | Transfer to menu screen. | F8 |
| F9 | | | | | | | INTERP. | ON <u>OFF</u> | F9 |
| F10 | | | | | | | | | F10 |
| F11 | | | PREROLL | nSEC 1 ≤ n ≤ 30 <u>n=5</u> | | | | | F11 |
| F12 | | | STILL | 1/3/30 SEC <u>1/3/5</u> MIN | | | STATE | Transfer to STATE menu. | F12 |
| F13 | REC INH | <u>FREE</u> NRML. REC ALL | STBY OFF | 1/3/30 SEC <u>1/3/16</u> MIN ∞ | | | * DOWN CONV | Transfer to down- converter menu | F13 |

• Underlined mode in the item selected indicates the initial setting.

* Display appears when the optional down-converter board has been installed.

List of MENU screens (Continued)

| FUNC key | Menu | | | | | | | | FUNC key |
|----------|-----------------------------|--|--------------|-----------------------------------|-----------------|------------------------------|------------------------------------|--------------------------------|----------|
| | VIDEO OUT/DOWN, CONV SET UP | | AUDIO IN | | AUDIO IN SET UP | | AUDIO OUT | | |
| | Setting item | Item selected | Setting item | Item selected | Setting item | Item selected | Setting item | Item selected | |
| F1 | TYPE | <u>COMPST</u> 4:2:2 4:2:2W 4:2:0p | CH-1 | ANALOG AES SERIAL INT SG | | | JOG/VAR PROCESS AUDIO CH1 | ON OFF | F1 |
| F2 | ASPECT | <u>SQUEEZE</u> LETTER SIDE CUT FULL | CH-2 | | | | JOG/VAR PROCESS AUDIO CH2 | | F2 |
| F3 | SYS PHASE | <u>UNITY</u> VAR | CH-3 | | | | JOG/VAR PROCESS AUDIO CH3 | | F3 |
| F4 | S AUDIO | ON OFF | CH-4 | | | | JOG/VAR PROCESS AUDIO CH4 | | F4 |
| F5 | SYNC | ON OFF | PEAK HOLD | ON OFF | | | PEAK HOLD | ON OFF | F5 |
| F6 | SYS H | <u>UNITY</u> VAR | SCALE | FINE <u>FULL</u> | CH-MIX | ON | SCALE | FINE <u>FULL</u> | F6 |
| F7 | SYS SC | <u>UNITY</u> VAR | EMPHASIS | ON OFF | CH-MIX | OFF | MONI AUTO | <u>SHTL</u> OFF VAR/SHTL | F7 |
| F8 | EXT | | SET UP | | EXIT | | SET UP | Transfer to menu screen. | F8 |
| F9 | V. ENHANC | ON OFF | REC VR | FINE <u>COARSE</u> | CUE | D-MIX <u>LINE</u> AUTO | PB VR | FINE <u>COARSE</u> | F9 |
| F10 | H. ENHANC | ON OFF | | | CUE MIX CH-1 | SOURCE TAPE OFF | MASTER VR CH1 | ON OFF | F10 |
| F11 | 7.5% STUP | ON OFF | | | CUE MIX CH-2 | | MASTER VR CH2 | | F11 |
| F12 | H. POSIT | <u>UNITY</u> VAR | | | CUE MIX CH-3 | | MASTER VR CH3 | | F12 |
| F13 | MARKER | ON OFF | | | CUE MIX CH-4 | | MASTER VR CH4 | | F13 |

•Underlined mode in the item selected indicates the initial setting.

| FUNC key | Menu | | | | | | | | FUNC key |
|----------|------------------|---------------------------|--------------------------------------|-----------------------|--------------|--|------------------|------------------|----------|
| | AUDIO OUT SET UP | | AUDIO OUT SET UP/ VIDEO OUT STATE | | TC/CHR | | MULTI CUE (USER) | | |
| | Setting item | Item selected | Setting item | Item selected | Setting item | Item selected | Setting item | Item selected | |
| F1 | A/V PHASE | UNITY | STBY OFF | <u>FREEZE</u> MUTE | SOURCE | <u>INT</u> EXT LTC S LTC S VTC | 1 | | F1 |
| F2 | | | | | TC SLAVE | <u>AUTO</u> PRESET SLAVE DIRECT | 2 | | F2 |
| F3 | STOP FD | <u>ON</u> OFF | | | UB SLAVE | <u>ON</u> OFF | 3 | | F3 |
| F4 | PB FADE | <u>ON</u> OFF | | | RUN MD | <u>REC RUN</u> FREE RUN | 4 | | F4 |
| F5 | PB OUT | <u>INSTANT</u> DELAYED | | | DF MD | <u>ON</u> OFF | 5 | | F5 |
| F6 | A. MONI | UNITY <u>VAR</u> | | | | | SETTING | <u>ON</u> OFF | F6 |
| F7 | | | | | | | ALL CLR | | F7 |
| F8 | EXIT | | EXIT | | | | | | F8 |
| F9 | | | | | | | 6 | | F9 |
| F10 | | | | | TCR | LTC <u>AUTO</u> VITC | 7 | | F10 |
| F11 | | | | | SUPER | TC <u>TC. ST.</u> OFF | 8 | | F11 |
| F12 | STATE | Transfer to menu screen. | | | SUPER ER | <u>ON</u> OFF | 9 | | F12 |
| F13 | | | | | CHAR TYPE | <u>REVERSE</u> NORMAL INTENSE | 10 | | F13 |

•Underlined mode in the item selected indicates the initial setting.

List of MENU screens (Continued)

| FUNC key | Menu | | | | | | | | FUNC key |
|----------|--------------------|--------------------------|---------------------------|-------------------------------|-------------------------|--------------------------|--------------------|--|----------|
| | MULTI CUE (EXTEND) | | MULTI CUE (EXTEND) SET UP | | MANUAL EDIT | | MANUAL EDIT SET UP | | |
| | Setting item | Item selected | Setting item | Item selected | Setting item | Item selected | Setting item | Item selected | |
| F1 | 1 | | AUTO STEP | <u>ON</u> OFF | VIDEO | <u>ON</u> OFF | TIMING | <u>F1</u> F2 F1/F2 | F1 |
| F2 | 2 | | PAG MODE | <u>ON</u> OFF | CH-1 | <u>ON</u> OFF | | | F2 |
| F3 | 3 | | PAG CLR | | CH-2 | <u>ON</u> OFF | | | F3 |
| F4 | 4 | | | | CH-3 | <u>ON</u> OFF | | | F4 |
| F5 | 5 | | ALL CLR | | CH-4 | <u>ON</u> OFF | | | F5 |
| F6 | PROTECT | | | | CUE | <u>ON</u> OFF | | | F6 |
| F7 | | | | | TC | <u>ON</u> OFF | | | F7 |
| F8 | SET UP | Transfer to menu screen. | EXIT | | SET UP | Transfer to menu screen. | EXIT | | F8 |
| F9 | 6 | | CLUTHC | <u>ON</u> OFF | INSERT/ ASSEMBLE | <u>ON</u> OFF | ERR. STP | <u>ON</u> OFF | F9 |
| F10 | 7 | | MAX SP | <u>-1↔+2</u> -1↔+1 0↔+1 | | | TRACKING | <u>VAR</u> FIX <u>OPT ONCE</u> OPT AUTO | F10 |
| F11 | 8 | | AUTO FRZ | <u>ON</u> OFF | | | | | F11 |
| F12 | 9 | | | | AUTO/ MANUAL EDIT | AUTO EDIT | FD TIME | <u>5/10/15/</u> 20/25/50 100 ms | F12 |
| F13 | 10 | | PREROLL | <u>nSEC</u> 1≤n≤30 n=5 | | | MODE | <u>X FADE</u> CUT V FADE | F13 |

•Underlined mode in the item selected indicates the initial setting.

| FUNC key | Menu | | | | | | | | FUNC key |
|----------|-------------------------|--------------------------|------------------|--------------------------------------|--------------|--------------------------|-------------------|---|----------|
| | AUTO EDIT | | AUTO EDIT SET UP | | SET UP | | INTERFACE SET UP | | |
| | Setting item | Item selected | Setting item | Item selected | Setting item | Item selected | Setting item | Item selected | |
| F1 | LAST X | LOAD <u>OFF</u> | TIMING | F1 F2 F1/F2 | HOME | Transfer to menu screen. | P-2 | MODE-1 MODE-2 MODE-3 MODE-4 OFF | F1 |
| F2 | LAST ED | LOAD <u>OFF</u> | V PREV | VVV VBV | MAN EDIT | Transfer to menu screen. | RS-232C | ON <u>OFF</u> | F2 |
| F3 | W/PLYR | ON <u>OFF</u> | A PREV | SSS SMS | AUTO EDIT | Transfer to menu screen. | PARA | ON <u>OFF</u> | F3 |
| F4 | VAR MEMO | ON <u>OFF</u> | PLYR-SYNC | ON <u>OFF</u> | SYSTEM | Transfer to menu screen. | AV CONT | ON <u>OFF</u> | F4 |
| F5 | PLYR SEL | PLYR-1 PLYR-2 | PREROLL | nSEC 1 ≤ n ≤ 30 n = 5 | DOWN CONV | Transfer to menu screen. | FF/REW MAX SP. | 32/50 | F5 |
| F6 | R/P SEL | PLAYER RECORDER | POSTROLL | nSEC 1 ≤ n ≤ 30 n = 2 | AUDIO IN | Transfer to menu screen. | DIV ID | ID-1 ID-2 ID-3 <u>DEFAULT</u> | F6 |
| F7 | TRIM | ON <u>OFF</u> | REACTION | nFR 0 ≤ n ≤ 25 n = 0 | AUDIO OUT | Transfer to menu screen. | | | F7 |
| F8 | SET UP | Transfer to menu screen. | EXIT | | | | EXIT | | F8 |
| F9 | INSERT/ ASSEMBLE | ON <u>OFF</u> | DLY STRT | ± n frames 1 ≤ n ≤ 30 n = 0 | | | UB PRESET | L & V LTC VITC | F9 |
| F10 | SPLIT | ON <u>OFF</u> | TRACKING | VAR FIX OPT. ONCE OPT. AUTO | INTERFACE | Transfer to menu screen. | VAR LIM | ON <u>OFF</u> | F10 |
| F11 | SPOT ERS | ON <u>OFF</u> | | | PANEL | Transfer to menu screen. | | | F11 |
| F12 | AUTO/ MANUAL EDIT | MANUAL EDIT | FD TIME | 5/10/15/ 20/25/50/ 100 ms | USER | Transfer to menu screen. | | | F12 |
| F13 | CH SELECT | Transfer to menu screen. | MODE | X FADE <u>CUT</u> V FADE | | | | | F13 |

• Underlined mode in the item selected indicates the initial setting.

List of MENU screens (Continued)

| FUNC key | Menu | | | | | | | | FUNC key |
|----------|---------------|----------------------------------|--------------|-----------------------------|--------------------|------------------------|--------------|--------------------------|----------|
| | PANEL SET UP | | USER SET UP | | SET UP SYSTEM | | TEST | | |
| | Setting item | Item selected | Setting item | Item selected | Setting item | Item selected | Setting item | Item selected | |
| F1 | SOUND KEY | <u>OFF</u> HIGH LOW | LOAD | | 1125/720p | <u>1125</u> 720p | VIDEO | Transfer to menu screen. | F1 |
| F2 | SOUND ALARM | <u>OFF</u> HIGH LOW | SAVE | | FLD RATE | 60 <u>59</u> | RF | Transfer to menu screen. | F2 |
| F3 | JOG MAX SP | -2↔+2 -1↔+1 <u>-1↔+2</u> | DELETE | | VIDEO IN ACT LINE | <u>1080</u> 1035 | AUDIO | Transfer to menu screen. | F3 |
| F4 | SHTL L/C/R | <u>ON</u> OFF | | | VIDEO OUT ACT LINE | <u>1080</u> 1035 | MECHA | Transfer to menu screen. | F4 |
| F5 | SHTL x8, x4 | <u>OFF</u> x8 x8, x4 x4 | POWER UP | <u>LAST FACTORY</u> 1-10 | DATA | <u>10 BIT</u> 8 BIT | SYSTEM | Transfer to menu screen. | F5 |
| F6 | SHTL MAX SP | <u>16/32/50</u> | | | ROUND | <u>ON</u> OFF | FRONT | Transfer to menu screen. | F6 |
| F7 | A. SCALE | <u>-20 dB</u> 0 dB | | | | | SERVO | Transfer to menu screen. | F7 |
| F8 | EXIT | | EXIT | | EXIT | | | | F8 |
| F9 | | | LOCK | | HD S AUDIO | <u>ON</u> OFF | | | F9 |
| F10 | LOCAL OP MAP | Transfer to menu screen. | PASS-WORD | | HD S LTC | <u>ON</u> OFF | | | F10 |
| F11 | REMOTE OP MAP | Transfer to menu screen. | | | HD S VITC | <u>ON</u> OFF | | | F11 |
| F12 | VAR MAX SP | <u>-1↔+2</u> -1↔+1 0↔+1 | | | | | | | F12 |
| F13 | VAR CLUTCH | <u>ON</u> OFF | | | | | IC CARD | Transfer to menu screen. | F13 |

•Underlined mode in the item selected indicates the initial setting.

| FUNC key | Menu | | | | | | | | FUNC key |
|-------------|-----------------|--|--------------------|----------------------------------|-----------------|------------------|-----------------|--------------------------|-------------|
| | VIDEO TEST | | RF TEST | | AUDIO TEST | | MECHA TEST | | |
| | Setting item | Item selected | Setting item | Item selected | Setting item | Item selected | Setting item | Item selected | |
| F1 | | | ECC SMPL | <u>SLOW</u> FAST | | | MODE | <u>NORMAL</u> NO-TAPE | F1 |
| F2 | | | METER | <u>ERROR</u> ENV | | | | | F2 |
| F3 | | | | | ABYP | | C. SIZE | | F3 |
| F4 | | | LOAD | | EE1 | | | | F4 |
| F5 | CF DET | <u>FIX</u> FREE | | | EE2 | | SENSOR | | F5 |
| F6 | OUT REF | <u>AUTO</u> INPUT HD REF NTSC REF | ADJ MODE | <u>FIX</u> AUTO EQ | | | | | F6 |
| F7 | | | ADJ CH | <u>CH0</u> CH1 CH2 CH3 | | | | | F7 |
| F8 | EXIT | | EXIT | | EXIT | | EXIT | | F8 |
| F9 | | | REC CURR OPT | | | | | | F9 |
| F10 | TEST CIRCUIT | EE1 EE2 EE3 | AT HEIGHT | | | | | | F10 |
| F11 | INPUT SELECT | VIDEO <u>DIGITAL</u> INT SG | ADJ RF | | | | | | F11 |
| F12 | | | ADJ SEL | <u>D5 EQ</u> D5 REC D5 PLL | | | | | F12 |
| F13 | | | HEAD CLN | | | | | | F13 |

•Underlined mode in the item selected indicates the initial setting.

List of MENU screens (Continued)

| FUNC key | Menu | | | | | | | | FUNC key |
|----------|--------------|---------------|--------------|--|--------------|--------------------------|--------------|--------------------------|----------|
| | SYSTEM TEST | | SERVO TEST | | FRONT TEST | | TEST IC CARD | | |
| | Setting item | Item selected | Setting item | Item selected | Setting item | Item selected | Setting item | Item selected | |
| F1 | | | TORQUE | | PANEL | Transfer to menu screen. | USER_FIL | Transfer to menu screen. | F1 |
| F2 | | | DATA SEND | | KEY CHECK | Transfer to menu screen. | MULT_CUE | Transfer to menu screen. | F2 |
| F3 | | | MEASURE | <u>OFF</u> LOADING | | | ERR_LOG | Transfer to menu screen. | F3 |
| F4 | | | AT | | | | | | F4 |
| F5 | | | METER | <u>ERROR</u> ENV | | | | | F5 |
| F6 | | | PG SHIFT | | | | | | F6 |
| F7 | | | ADJ RATE | <u>FINE</u> COARSE | | | | | F7 |
| F8 | EXIT | | EXIT | | EXIT | | EXIT | | F8 |
| F9 | | | MECHA | | | | | | F9 |
| F10 | | | TRACKING | <u>VAR</u> FIX <u>OPT ONCE</u> OPT AUTO | | | | | F10 |
| F11 | | | | | | | | | F11 |
| F12 | | | BIMORPH INIT | | | | | | F12 |
| F13 | | | ADJ ENABLE | | | | FORMAT | | F13 |

• Underlined mode in the item selected indicates the initial setting.

[A]

- AV phase adjustment, *AUDIO OUT SET UP/F1/80*, 81
- ADJUST control, —/—/20
- Alarm tone setting, *PANEL SET UP/F2/127*
- Aspect, *VIDEO OUT/DOWN CONV SET UP/F2/69*
- ASSEMBLE button, —/—/20
- Assemble editing: automatic editing, *AUTO EDIT/F12/45*, 108
 - manual editing, *MANUAL EDIT/F12/42*, 99
- AT head hysteresis elimination, *SERVO TEST/F12/156*
- AT playback selector, *HOME SET UP/F2/59*
- Audio digital processing in JOG/VAR mode, *AUDIO OUT/F1–F4/78*
- Audio fading: fade playback, *AUDIO OUT SET UP/F4/80*
 - fade editing (during manual editing), *MANUAL EDIT SET UP/F12–F13/101*, 106
 - cross fade manual editing, —/—/44
 - fade editing (during automatic editing), *AUTO EDIT SET UP/F12–F13/106*, 117
- Audio monitoring: monitor channel selection, *AUDIO OUT/F7/78*
 - monitor volume adjustment, *AUDIO OUT SET UP/F6/80*
- Audio/video delay adjustment, *AUDIO OUT SET UP/F1/80*, 81
- Audio: recording level adjustment (FINE/COARSE), *AUDIO IN/F9/72*
 - playback level adjustment (FINE/COARSE), *AUDIO OUT/F9/78*
 - audio signal digital processing in JOG/VAR mode, *AUDIO OUT/F1–F4/78*
 - split editing, *AUTO EDIT/F10/48*, 49, 108
 - channel input selection, *AUDIO IN/F1–F4/71*
 - channel ON/OFF, *MANUAL EDIT/F2–F5/99*
 - channel mixing, *AUDIO IN SET UP/F6–F7/74–76*
 - input signal recording level adjustment, *HOME/—/51*
 - output signal level adjustment, *HOME/—/51*
 - state, *AUDIO OUT SET UP/F12/67*, 80
 - input signal bypass, *AUDIO TEST/F3–F5/151*
 - peak hold, *AUDIO IN/F5/72*
 - AUDIO OUT/F5/78*
 - audio output adjustment (to video), *AUDIO OUT SET UP/—/81*
 - master VR ON/OFF, *AUDIO OUT/F10–F13/78*
 - monitor L/R button, —/—/15
 - selection of signal output from monitor terminal, *AUDIO OUT/F7/78*
 - monitor volume adjustment, *AUDIO OUT SET UP/F6/80*
 - level meter scale selection, *AUDIO IN/F6/72*
 - AUDIO OUT/F6/78*
- AUTO OFF error message, *AUTO OFF/—/180–182*
- Automatic editing, *AUTO EDIT/F12/45*, 46, 108
- Automatic file loading after power-on, *USER SET UP/F5/137*

Italic letter indicates the Menu/Function Key/Page.

[B]

Basic operations (STOP/FF/REW/READY/JOG/SHTL/VAR, tape speed override), —/—/38–42
Black level adjustment, *VIDEO OUT/F4/65*
Bypass: audio circuit test, *AUDIO TEST/F3–F5/151*
video circuit test, *VIDEO TEST (circuit test)/F1–F3/145*

[C]

Cassette tape, —/—/31
CF lamp, —/—/18
Channel assign, *INTERFACE SET UP/—/125*
Color frame: detection mode selection, *HOME SET UP/—/61*
Connections, —/—/28–30
Connector: connector section, —/—/23–27
signals, —/—/195–200
Control signal resetting, *HOME/F6/57*
Cue, —/—/41
Cue audio: D MIX signal selection, *AUDIO IN SET UP/F9/74*
channel ON/OFF, *AUDIO IN SET UP/F10–F13/74*
editing ON/OFF, *MANUAL EDIT/F6/99*
Cue: search, —/—/41
setting and entry, *MULTI CUE (USER)/F6/89, 91*
modification and clearing, *MULTI CUE (USER)/—/92*
designating numbers, *MULTI CUE (USER)/F1–F5, F9–F13/89*
MULTI CUE (EXTEND)/F1–F5, F9–F13/94
clearing all cue data, *MULTI CUE (USER)/F7/89, 92*
MULTI CUE (EXTEND) SET UP/F5/97
clearing cue data on a page, *MULTI CUE (EXTEND) SET UP/F3/97*
preroll time selection, *MULTI CUE (EXTEND) SET UP/F13/97*
cursor movement ON/OFF, *MULTI CUE (EXTEND) SET UP/F2/97*
automatic cursor movement, *MULTI CUE (EXTEND) SET UP/F1/97*
protection, *MULTI CUE (EXTEND)/F6/94, 95*
Cursor, —/—/21

Italic letter indicates the Menu/Function Key/Page.

[D]

Device ID setting matched to controller, *INTERFACE SET UP/F6/122*
Diagnosis (DIAG) error messages, *DIAG/—/171–179*
Digital signal recording, *—/—/35, 36*
Down converter, *VIDEO OUT/DOWN CONV SET UP/F1–F13/69, 70*

[E]

Editing: edit channel selection during manual editing, *MANUAL EDIT/F1–F7, F12/99*
edit channel selection during automatic editing, *AUTO EDIT/F12–F13/108*
edit mode selection during manual editing, *MANUAL EDIT/F9/99*
edit mode selection during automatic editing, *AUTO EDIT/F9/108*
Edit REC inhibit setting during manual editing, *MANUAL EDIT SET UP/—/102, 103*
timing selection, *MANUAL EDIT SET UP/F1/101*
AUTO EDIT SET UP/F1/116
loading data (last edit data input), *AUTO EDIT/F1/108, 112*
loading data (all data input last), *AUTO EDIT/F2/108, 112*
duration, *AUTO EDIT/—/109*
out point previewing, *—/—/48, 49*
preroll time selection, *HOME SET UP/F11/59*
AUTO EDIT SET UP/F5/116, 118
MULTI CUE (EXTEND) SET UP/F13/97
preview audio signal selection, *AUTO EDIT SET UP/F3/116*
preview video signal selection, *AUTO EDIT SET UP/F2/116*
postroll time setting, *AUTO EDIT SET UP/F6/116*
react time (operation delay compensation time) setting, *AUTO EDIT SET UP/F7/116*
selecting VTR (player/recorder) to be operated, *AUTO EDIT/F6/108*
selecting VTR (player) to be operated, *AUTO EDIT/F5/108*
delay (startup from playback command) setting, *AUTO EDIT SET UP/F9/116, 118*
edit point input, *AUTO EDIT/—/110–112*
edit point recording field selection (during automatic editing) setting, *AUTO EDIT SET UP/F1/116*
edit point recording field selection (during manual editing) setting, *MANUAL EDIT SET UP/F1/101*
edit point trimming, *AUTO EDIT/F7/108, 109*
execution of editing, *—/—/43–47*
Emphasis (pre-emphasis) setting, *AUDIO IN/F7/72*
Error display lamp, *—/—/18*
Error rate: measuring time selection, *RF TEST/F1/148*
level display selection, *RF TEST/F2/148*
SERVO TEST/F5/156

Italic letter indicates the Manu/Function Key/Page.

[F]

Fade: during playback, *AUDIO OUT SET UP/F4/80, 81*
during manual editing, *MANUAL EDIT SET UP/F12–F13/101, 106*
during automatic editing, *AUTO EDIT SET UP/F12–F13/117*

FF/REW maximum speed setting, *INTERFACE SET UP/F5/122*

Field/frame playback in JOG/VAR mode, *HOME SET UP/F2/59*

Files: loading, *USER SET UP/F1/134, 137*
saving, *USER SET UP/F2/134*
updating, *USER SET UP/—/136*
deleting, *USER SET UP/F3/134, 137*
copying, *USER SET UP/—/137*
loading after power-on, *USER SET UP/F5/134, 137*
locking, *USER SET UP/F9/134, 136*
password, *USER SET UP/F10/134, 135*

Flash freeze frame output, *HOME/F2/56*

Front panel, *—/—/15–22*

[H]

Head cleaning, *RF TEST/F13/148*

Headphones jack/VR, *—/—/16*

HOME button, *—/—/20*

[I]

IC card, *TEST/F13/162–169*

Input signal selection, *VIDEO TEST/F11/32, 144, 146*

INSERT button, *—/—/20*

Insert editing: automatic editing, *AUTO EDIT/F9, F12/45, 46, 108*
manual editing, *MANUAL EDIT/F9, F12/43, 44, 99*
edit channel selection (during automatic editing), *AUTO EDIT/F12, F13/108, 109*
edit channel selection (during manual editing), *MANUAL EDIT/F1–F7, F12/99*

Internal generator field frequency setting, *SET UP SYSTEM/F2/140*

Internal signal generator signal selection, *VIDEO TEST/F4/146*
VIDEO IN/F4/63

Installation, *—/—/201*

Italic letter indicates the Menu/Function Key/Page.

[J]

JOG button, —/—/20

[K]

Key touch tone selection, *PANEL SET UP/F1/127*

[L]

Last edit (all data input last) loading, *AUTO EDIT/F2/108, 112*

Last X (last edit data input) loading, *AUTO EDIT/F1/108, 112*

Level adjustment VR, —/—/16

Level meter peak hold: audio input, *AUDIO IN/F5/72*

audio output, *AUDIO OUT/F5/78*

Level meter scale selection: audio input, *AUDIO IN/F6/72*

audio output, *AUDIO OUT/F6/83*

Loading: no-tape loading operation test, *MECHA TEST/F1/153*

cassette size selection, *MECHA TEST/F3/153*

Local mode: video level adjustments, *PANEL SET UP (LOCAL)/F1/132*

audio level adjustments, *PANEL SET UP (LOCAL)/F2/132*

tracking adjustment, *PANEL SET UP (LOCAL)/F3/132*

monitor adjustment, *PANEL SET UP (LOCAL)/F4/132*

key operation selection, *PANEL SET UP (LOCAL)/F5/132*

[M]

Manual editing, *MANUAL EDIT/F12/43, 44, 108*

Master VR ON/OFF, *AUDIO OUT/F10–F13/78*

Menu screen transfer list, —/—/206–212

Mode terminal correlation table, *INTERFACE SET UP/—/123*

Monitor terminal output audio signal volume adjustment, *AUDIO OUT SET UP/F6/80*

Monitor terminal output signal selection, *AUDIO OUT/F7/78*

Multi cue, *See cue*

MULTI CUE button, —/—/24

Italic letter indicates the Menu/Function Key/Page.

[O]

OP MAP setting method: remote, *PANEL SET UP (REMOTE)/—/130*
local, *PANEL SET UP (LOCAL)/—/132*
Operation messages, —/—/186, 187
Operation time display, *TEST/—/142*
Output signal (TAPE/EE) selection, *HOME/F1/56*
Output signal selection is standby (READY) OFF, *AUDIO OUT SET UP/VIDEO OUT STATE/F1/67, 68*

[P]

PB fade ON/OFF, *AUDIO OUT SET UP/F4/80, 81*
P_B level adjustment, *VIDEO OUT/F2/65, 66*
PB OUT (output audio characteristics at playback start), *AUDIO OUT SET UP/F5/80*
Peak hold: audio input values, *AUDIO IN/F5/72*
audio output values, *AUDIO OUT/F5/78*
Playback, —/—/37
Player 1/Player 2 selection, *AUTO EDIT/F5/108*
Player synchronization, *AUTO EDIT SET UP/F4/116*
Player/recorder selection, *AUTO EDIT/F6/108*
P_R level adjustment, *VIDEO OUT/F3/65, 66*
Pre-emphasis function setting, *AUDIO IN/F7/72*
Preroll time selection, *HOME SET UP/F11/59*
AUTO EDIT SET UP/F5/116, 118
MULTI CUE (EXTEND) SET UP/F13/97
Preview audio signal selection, *AUTO EDIT SET UP/F3/116*
Preview video signal selection, *AUTO EDIT SET UP/F2/116*
Program play function setting, *HOME SET UP/F3–F4/58*

[R]

Rack mounting, —/—/202
Ratings, —/—/11–14
React time (operation delay compensation time) setting, *AUDO EDIT SET UP/F7/116*
REC CURRENT (recording current value) display, *RF TEST/F9/148, 149*
ENV/recording ENV display, *MANUAL EDIT SET UP/—/103*
REC INHIBIT selection: during recording, *HONE/F13/57*
during editing, *MANUAL EDIT SET UP/—/102*
REC level adjustment, *HONE/—/51*
Recording, —/—/32–36
Recording current level display, *RF TEST/F9/148, 149*

Italic letter indicats the Menu/Function Key/Pge.

Recording prohibit mode selection, *HOME/F13/57*
Reference selection, *VIDEO TEST/F6/144*
Remote mode: video level adjustment, *PANEL SET UP (REMOTE)/F1/129*
audio level adjustments, *PANEL SET UP (REMOTE)/F2/129*
tracking adjustment, *PANEL SET UP (REMOTE)/F3/129*
monitor adjustment, *PANEL SET UP (REMOTE)/F4/129*
key operation selection, *PANEL SET UP (REMOTE)/F5/129*
all functions enable/disable, *PANEL SET UP (REMOTE)/F6/129*
eject key operation enable, *PANEL SET UP (REMOTE)/F7/129*
Remote: 50 P parallel ON/OFF, *INTERFACE SET UP/F3/122*
RS-232C parameter setting, *INTERFACE SET UP/F2/122, 124*
RS-422A connected VTR ON/OFF, *AUTO EDIT/F3/108*
RS-422A P2 bus selection, *INTERFACE SET UP/F1/122, 123*
panel removal to operate, *—/—/192*
RF adjustment value display, *RF TEST/F11–F12/150*

[S]

Search dial: shuttle clutch point setting, *PANEL SET UP/F4–F5/127*
maximum shuttle speed selection, *PANEL SET UP/F6/127*
variable clutch point setting, *MULTI CUE (EXTEND) SET UP/F9/97*
PANEL SET UP/F13/127
maximum variable speed selection, *MULTI CUE (EXTEND) SET UP/F10/97*
PANEL SET UP/F12/127
maximum jog speed selection, *PANEL SET UP/F3/127*
Sensor operation check, *MECHA TEST/F5/153*
Serial V/A output, *SET UP SYSTEM/F9–F11/140*
SERVO lamp, *—/—/18*
SHTL (shuttle) button, *—/—/20*
Software version display, *TEST/—/142*
Split editing, *AUTO EDIT/F10/48, 108*
Spot erase, *AUTO EDIT/F11/47, 108*
Standby mode retention time selection, *HOME SET UP/F13/59*
Still mode retention time selection, *HOME SET UP/F12/59*
Superimpose: setting, *TC/CHR/F11/84*
setting error message ON/OFF, *TC/CHR/F12/84, 86*
character selection, *TC/CHR/F13/84*
position change, *TC/CHR/—/85*
Sync play ON/OFF, *HOME SET UP/F1/59*
System error message, *—/—/183–185*
SYSTEM lamp, *—/—/18*

Italic letter indicates the Menu/Function Key/Page.

[T]

- Tape, —/—31
- Tape position indicator, *AUTO EDIT*/—/109
- Tape status setting in standby (READY) OFF, *HOME SET UP*/F6/59
- Test front: key check, *TESTFRONT*/F2/158, 159, 161
 - panel, *TESTFRONT*/F1/158, 160
- Time code: VITC recording mode selection, *TC/CHR*/F7/83
 - TC channel ON/OFF, *MANUAL EDIT*/F7/99
 - superimpose ON/OFF, *TC/CHR*/F11/84
 - slave lock mode ON/OFF, *TC/CHR*/F12/84
 - default setting, *HOME*/—/54
 - internal/external input selection*, *TC/CHR*/F1/83
 - drop/non-drop frame selection, *TC/CHR*/F5/83, 85
 - REC RUN/FREE RUN selection, *TC/CHR*/F4/83
 - time code value holding, *HOME*/F7/57
 - readout mode selection, *TC/CHR*/F10/84, 85
 - TC/UB selection*, *HOME*/F5/57
 - color frame bit addition, *TC/CHR*/F6/83
- Time data: *TC/CTL* selection, *HOME*/F4/57
 - reset, *HOME*/F6/57
- Tracking adjustment, *MANUAL EDIT SET UP*/F10/101, 104, 105
 - SERVO TEST*/F10/156

[U]

- UNITY lamp, —/—/15
- User bit: slave lock mode setting, *TC/CHR*/F3/83
 - user bit value display, *HOME*/F5/57
 - settings list, *TC/CHR VITC.L*/—/87
- User file: loading, *USER SET UP*/F1/134, 137
 - saving, *USER SET UP*/F2/134, 135
 - updating, *USER SET UP*/—/136
 - deleting, *USER SET UP*/F3/134, 137
 - copying, *USER SET UP*/—/138
 - automatic load setting after power-on, *USER SET UP*/F5/134, 137
 - locking, *USER SET UP*/F9/134, 136
 - password, *USER SET UP*/F10/134, 135

Italic letter indicates the Menu/Function Key/Page.

[M]

V/A control parameters, *INTERFACE SET UP/F4/122, 126*

VAR button, —/—/20

Variable memory, *AUTO EDIT/F4/108, 113, 114*

Video channel ON/OFF, *MANUAL EDIT/F1/99*

Video input: signal selection, *VIDEO IN/F1/63*

VIDEO TEST (internal input signal selection)/F1/144, 146

input signal bypass, *VIDEO TEST (circuit test)/F1–F3/145*

Video output: selecting TAPE/EE for each mode, *AUDIO OUT SET UP/VIDEO OUT STATE/—/67, 68*

video phase adjustment, *VIDEO OUT/F5/65*

black level adjustment, *VIDEO OUT/F4/65*

Video test circuit, *VIDEO TEST/F10/144, 145*

[W]

Waveform output, *HOME/—/52*

[Y]

Y level adjustment, *VIDEO OUT/F1/65, 66*

Italic letter indicates the Menu/Function Key/Page.

Panasonic

Broadcast & Television Systems Company

Division of Matsushita Electric Corporation of America

Executive Office:

One Panasonic Way (4B-7), Secaucus, NJ 07094

REGIONAL OFFICES:

EASTERN: New Jersey: One Panasonic Way, Secaucus, NJ 07094

Sales: Panazip 4B-7 (201) 348-7671

Washington, D.C. (703) 759-6900

SOUTHERN: 1225 Northbrook Parkway, Suite 107A, Suwanee, GA 30174

Sales: (404) 717-6772

CENTRAL: 1707 North Randall Road, Elgin, IL 60123 Panazip EIC-3

Sales: (708) 468-5160

WESTERN: 4001 W. Alameda Ave., Suite 100, Burbank, CA 91505

Sales: (818) 562-1501

PARTS INFORMATION & ORDERING:

9:00 a.m.—5:00 p.m. (EST) (800) 334-4881/24 Hr. Fax (800) 334-4880

TECHNICAL SUPPORT:

Emergency 24 Hour Parts & Service (800) 222-0741

TRAINING INFORMATION:

Digital System Products - (201) 392-6022

Panasonic Canada Inc.

5770 Ambler Drive, Mississauga, Ontario L4W 2T3 (905) 624-5010